

Dimensions

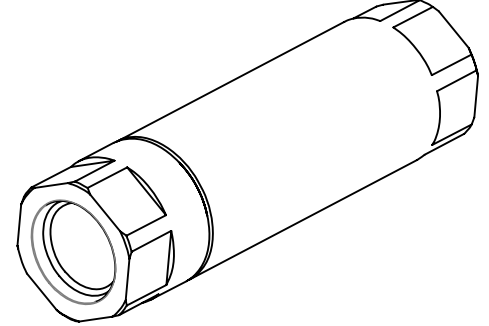

Hydraulic Symbol

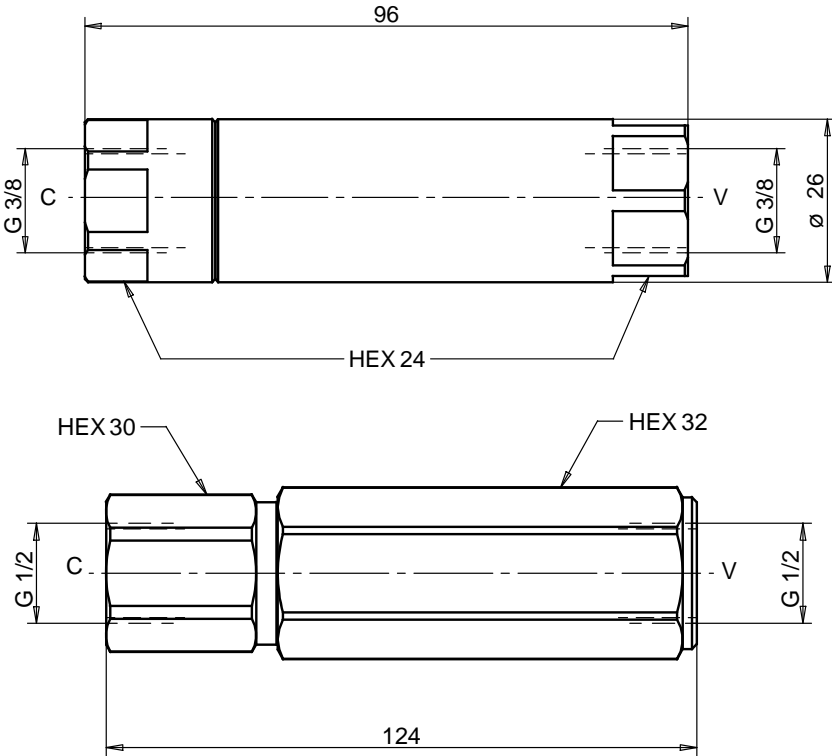
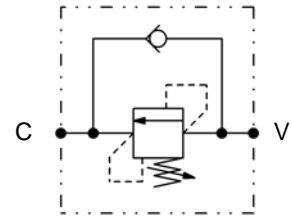

Curves

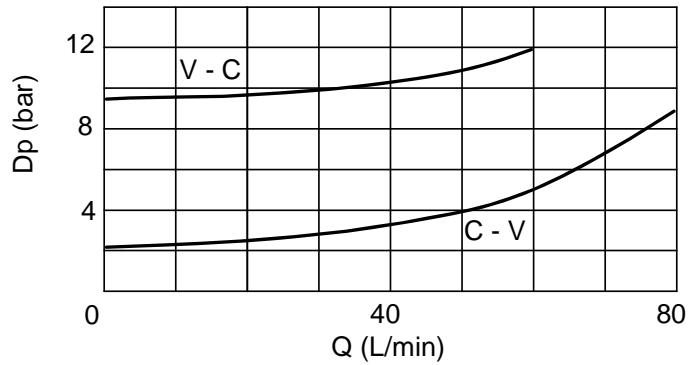

Features

Size	02	03
Max Flow (lpm)	40	80
Max Pressure (bar)	350	350

Materials: Zinc plated steel body, hardened steel inner parts.

Ordering Code

SVL		--	--
	Port Size BSP	LP-Spring (bar)	
02	3/8	10	02 03
03	1/2		30-120 30-140

Ordering Code Example: SVL0310 = 1/2 Port Size - 30-140 bar setting range.