

SV98-T40 Spool, 4-Way, 2-Position, Drop-In-Style

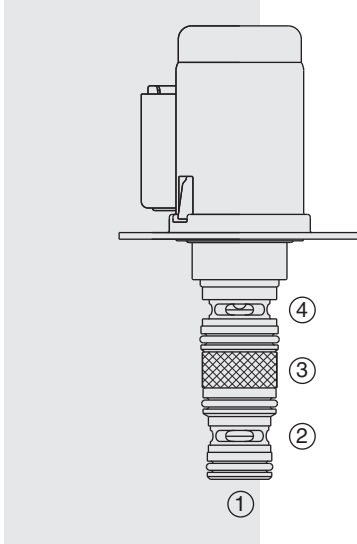

DESCRIPTION

An economical drop-in-style, direct-acting, balanced spool, two-position, four-way, directional control valve. It is well suited for use in specialized low-pressure pilot systems or power shift transmission control.

OPERATION

When de-energized, the **SV98-T40** allows flow from 3 to 2 and from 4 to 2. When energized, the cartridge's spool shifts to allow flow from 3 to 2 and from 4 to 1.

Pressure at 1(tank) should not exceed 3.4 bar (50 psi).

The coil is an integral part of the valve and is not serviceable.

FEATURES

- Economical drop-in style.
- Integral waterproof coil standard.
See page 3.400.1 for a description of tests conducted to verify coil waterproofing.
- 12 or 24 VDC coils.
- Several push-on termination options.

RATINGS

Operating Pressure: up to 30 bar (435 psi)

Flow: 30 lpm (8 gpm)

Internal Leakage: 70 ml/minute (4.3 cu. in./minute) maximum from inlet to tank at 30 bar (435 psi)

Temperature: -40°C to 149°C (-40°F to 300°F)

Coil Duty Rating: Continuous from 85% to 115% of nominal voltage

Response Time: First indication of change of state with 100% voltage and flow rating: Pull-in: 50 ms; Drop-out: 30 ms.

Initial Coil Current Draw at 20°C: 1.68 amps at 12 VDC

Minimum Pull-in Voltage: 85% of nominal at 30 bar (435 psi)

Filtration: See page 9.010.1

Fluids: Mineral-based or synthetics with lubricating properties at viscosities of 7.4 to 420 cSt (50 to 2000 sus); See Temperature and Oil Viscosity, page 9.060.1

Installation: Flange Mount

Flange Mounting Screws: M5 x 8; Part No. 4000039 (not provided with valve)

Cavity: VC-T004; See page 9.111.1

Cavity Tool: CT-T004R0-x-G; See page 8.600.1

Seal Kit: SK98-T4N-000; See page 8.650.1

SYMBOLS

USAS/ISO:

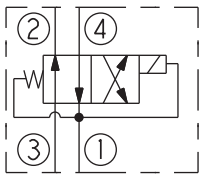

PERFORMANCE (Cartridge Only)

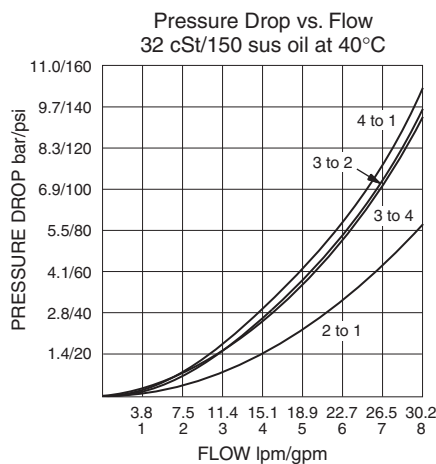

DIMENSIONS

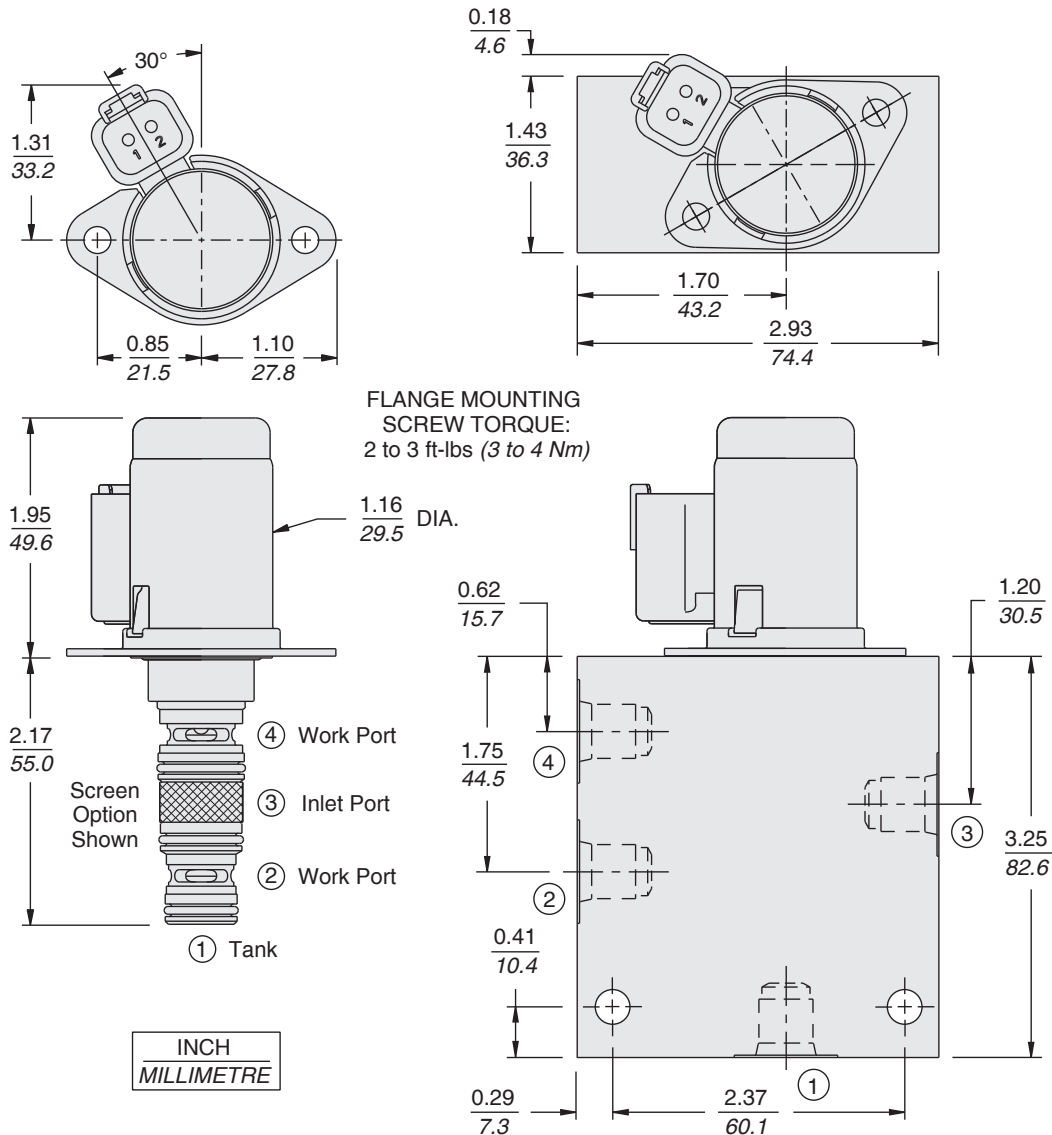

MATERIALS

Cartridge including Coil: Weight: 0.26 kg. (0.57 lbs.) Steel with hardened work surfaces. Zinc-Nickel plated exposed surfaces. HNBR O-rings standard. Coil is encapsulated, class H high-temperature magnetwire, with zinc-nickel plated shell.

Standard Ported Test Body: Weight: 0.11 kg. (0.25 lbs.) Anodized high-strength 6061 T6 aluminum alloy, rated to 207 bar (3000 psi). See page 8.010.1.

Mounting Screws: Must be ordered separately: Part No. 4000039

TO ORDER

SV98-T40

<p>Flange Standard (Blank) Lock Down L</p> <p>Option None (Blank) 233µ screen on inlet port 3 S</p> <p>Porting Cartridge Only 0 SAE 6 6T</p> <p>Seals Hydrogenated Nitrile (HNBR) N</p>	<p>Diode (Blank) None D Diode Z Bidirectional Zener Diode</p> <p>Termination DJ Amp Junior Timer Y2A Metri-Pack® 150.2A DR Deutsch DT04-2P</p> <p>Voltage 12 12 VDC 24 24 VDC</p>
--	---