

SV07-31 Spool, 3-Way

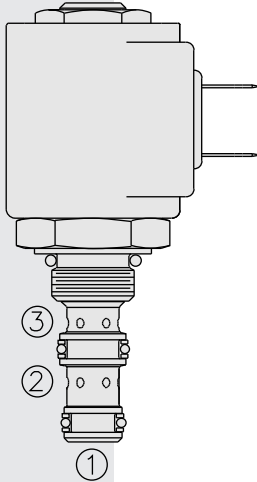

DESCRIPTION

A solenoid-operated, 3-way, direct-acting, spool-type, screw-in hydraulic cartridge valve.

OPERATION

When de-energized, the **SV07-31** allows flow from 2 to 1, while blocking flow at 3. When energized, the cartridge's spool shifts to open from 1 to 3, while blocking at 2. While port 1 may be fully pressurized, it is not intended to be used as the inlet.

FEATURES

- Continuous-duty rated solenoid.
- Hardened precision spool and cage for long life.
- Optional coil voltages and terminations.
- Efficient wet-armature construction.
- Cartridges are voltage interchangeable.
- All ports may be fully pressurized.
- Optional waterproof E-Coils rated up to IP69K.
- Unitized molded coil design.
- Compact size.

RATINGS

Operating Pressure: 207 bar (3000 psi)

Flow: See Performance Chart

Internal Leakage: 41 cc/minute (2.5 cu. in./minute) max. at 207 bar (3000 psi)

Temperature: -40 to 120°C with standard Buna seals

Coil Duty Rating: Continuous from 85% to 115% of nominal voltage

Initial Coil Current Draw at 20°C: Standard Coil: 1.2 amps at 12 VDC;
0.13 amps at 115 VAC (full wave rectified).

E-Coil: 1.4 amps at 12 VDC; 0.7 amps at 24 VDC

Minimum Pull-in Voltage: 85% of nominal at 207 bar (3000 psi)

Filtration: See page 9.010.1

Fluids: Mineral-based or synthetics with lubricating properties at viscosities of 7.4 to 420 cSt (50 to 2000 sus); See Temperature and Oil Viscosity, page 9.060.1

Installation: No restrictions; See page 9.020.1

Cavity: VC07-3; See page 9.107.1

Cavity Tool: CT07-3XX; See page 8.600.1

Seal Kit: SK07-3X-MM; See page 8.650.1

Standard Coil Nut: Part No. 7004400;

For E-coils manufactured prior to 1-1-04, see page 3.400.1 for coil nut info.

ISO SYMBOL

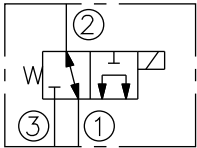

PERFORMANCE (Cartridge Only)

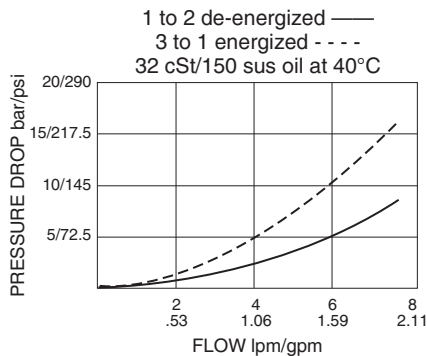

DIMENSIONS

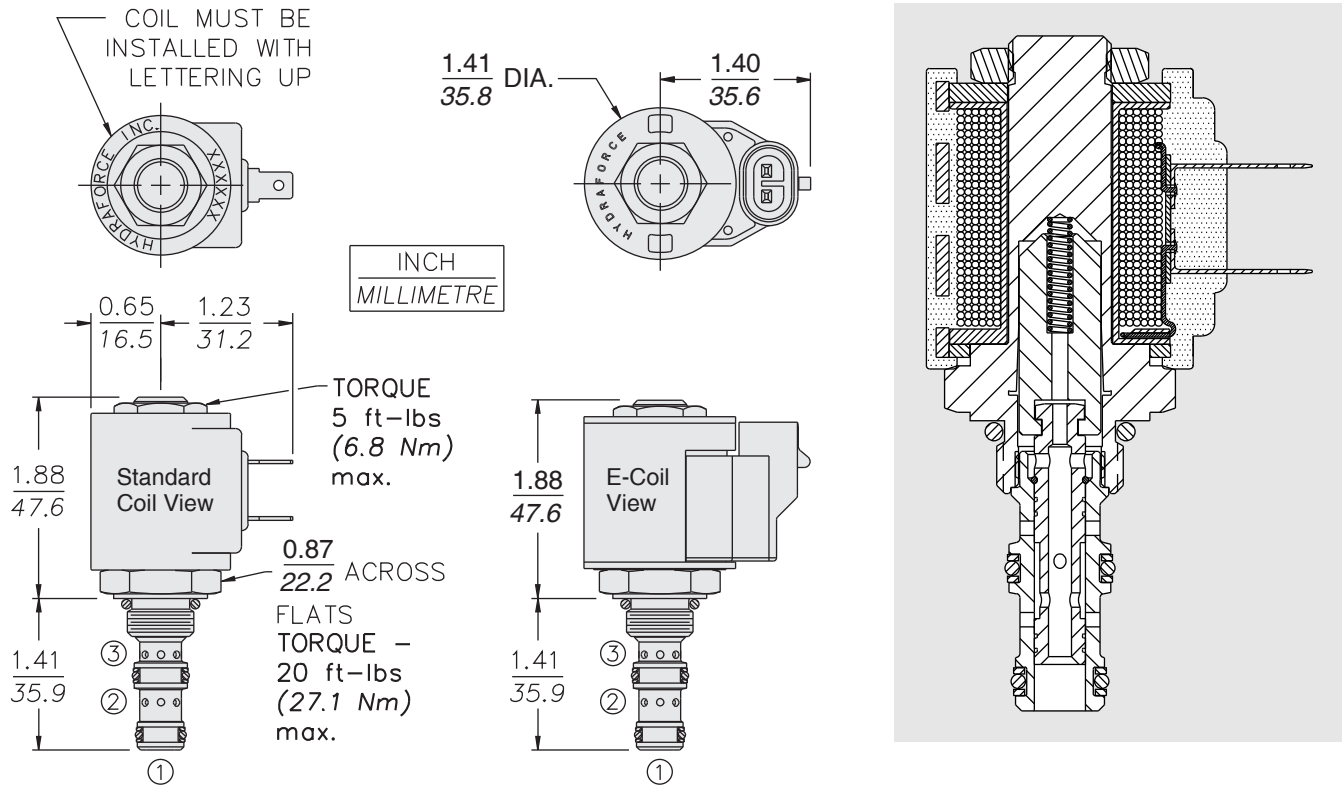

MATERIALS

Cartridge: Weight: 0.09 kg. (0.20 lbs.); Steel with hardened work surfaces. Zinc-plated exposed surfaces; Buna N O-rings and back-ups standard.

Standard Coil: Weight: 0.11 kg. (0.25 lbs.); Unitized thermoplastic encapsulated, Class H high temperature magnetwire. See page 3.200.1.

E-Coil: Weight: 0.14 kg. (0.3 lbs.); Perfect wound, fully encapsulated with rugged external metal shell; Rated up to IP69K with integral connectors.

Note: See page 3.400.1 for all E-Coil retrofit applications.

TO ORDER

