

SG 420

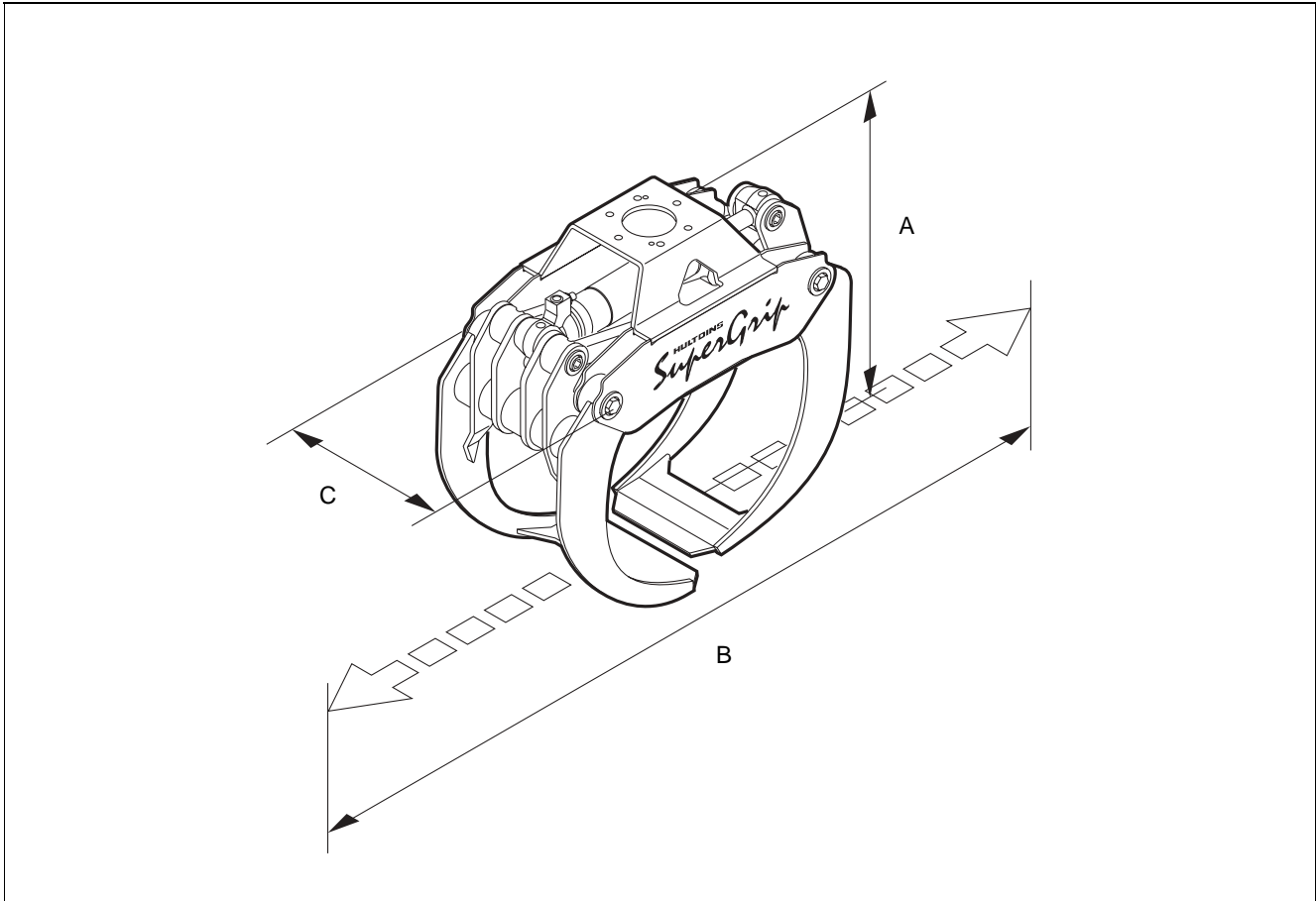

Fig. 13 Dimensions

	SG 420 LP	SG 420 HP	SG 420LP-R	SG 420HP-R
Gripping area, tip-tip	0.42 m ²	0.42 m ²	0.42 m ²	0.42 m ²
Max. gripping width (B).....	2 075 mm	2 075 mm	2 072 mm	2 072 mm
Min. gripping diameter	120 mm	120 mm	120 mm	120 mm
Max. load.....	5 500 kg	5 500 kg	5 500 kg	5 500 kg
Weight.....	276 kg	276 kg	308 kg	308 kg
Height, arms closed	649 mm	649 mm	649 mm	649 mm
Height, arms tip-tip (A)	1 040 mm	1 040 mm	1 040 mm	1 040 mm
Overall grapple width (C)...	510 mm	510 mm	510 mm	510 mm
Cylinder size.....	100/63	90/56	100/63	90/56
Cylinder connections	BSP 1/2" (-) BSP 3/4" (+)	UNF 1.1/16	BSP 1/2"(-) BSP 3/4"(+)	UNF 1.1/16