

FINN ROTOR

CR A-rotators

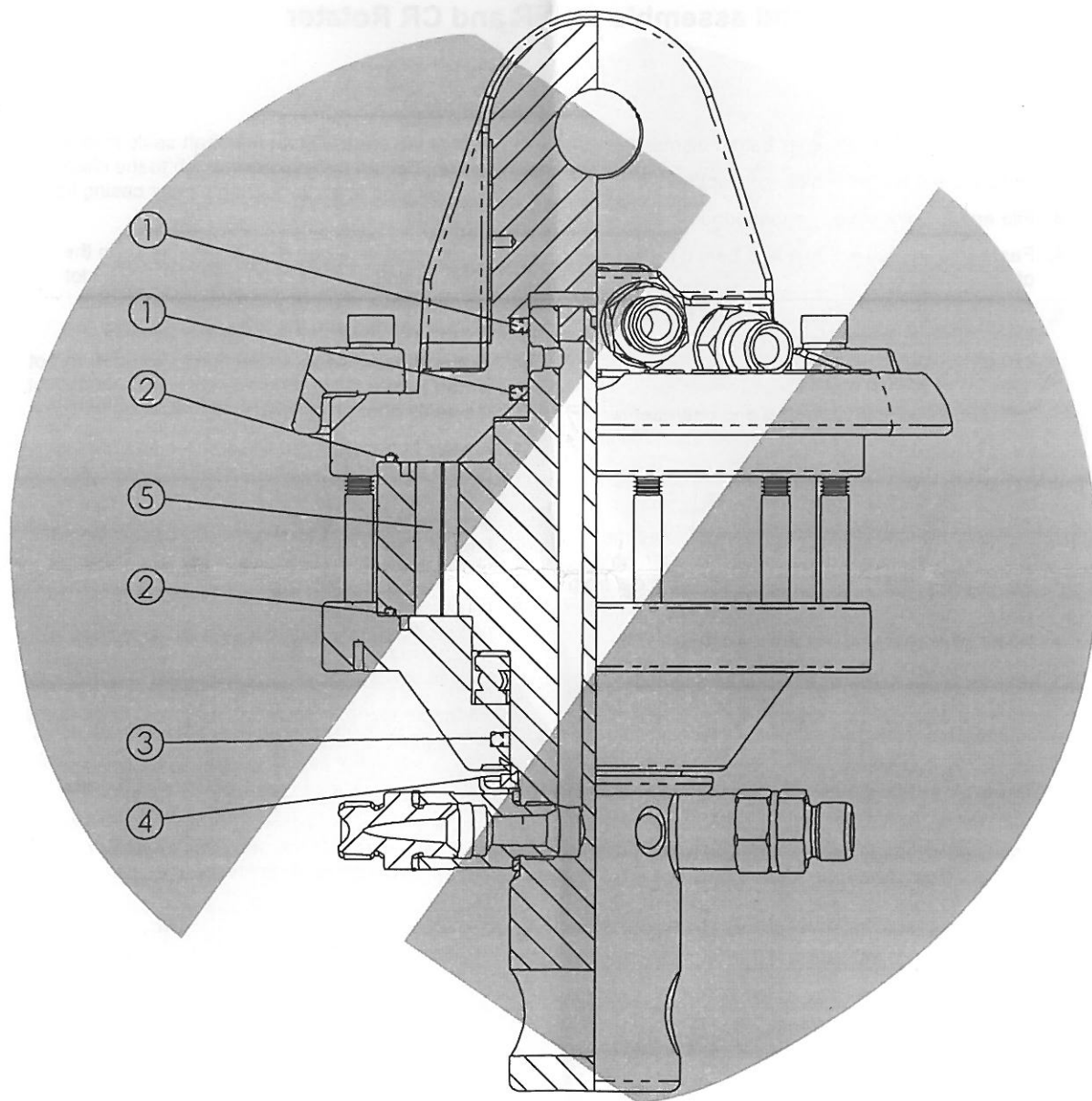

- 1. Rotator seals
- 2. O-rings
- 3. Rotator seal
- 4. VA-seal
- 5. Springs



How to dismantle and assemble the FR and CR Rotator

Dismantling

1. Clean and wash the rotator before dismantling.
2. Detach the hose protection and nipples.
3. File and sand down any sharp edges on the shaft.
4. Fasten the equipment to a vice bench by the lugs of the top casing.
5. Use a punch to mark the position of the top casing, bottom casing and chamber (stator) to each other.
6. Unscrew the Allen screws.
7. Lift so that the bottom casing and chamber remain on the shaft.
8. Use a felt tip pen to mark the position (which groove, wing, direction) of the wing.
9. Turn the shaft against the bench and prise the chamber and lower casing off of the shaft, holding the wings to prevent them from springing out from under the chamber.
10. Remove the seals and wash the parts.
11. Check for damage, clean any cuts by sanding carefully with an abrasive belt (400) using a level.

Screws 12.9 DIN 912	Tightening Torques	Rotator type
M 8	40 Nm	CR 100, CR 300
M 10	81 Nm	CR 400, CR500
M 12	125 Nm	CR 600

1 Nm 0,1 kpm 0,738 lbf·ft 8,85 lbf·in

Assembly

1. Test fit the shaft without the shaft seals in the lower casing. Fasten the assembly bush to the clamp and push the shaft through the lower casing into the bush.
2. There must be a gap of 0.05 mm between the lower casing and the shaft shoulder (wing slot frame), add a shim (0.025 mm) between the journal bearing and the lower casing.
3. Fit the slip ring seals. Heat the slip rings with a hot air fan before fitting, use a former sleeve to adjust the seals after fitting.
4. Always fit new springs. Place the wings and springs on the shaft, the wings against the lower casing. Use a clamp or band to tighten the wings into the slot. Press the chamber into place, at the same time letting the wings into the chamber frame. This means lifting the shaft out of the lower casing.
5. Fit the shaft, chamber and wings into the lower casing where the bearing case and seals are already in place. Lubricate the shaft seal with fitting grease and oil the other surfaces with hydraulic oil.
6. Fit the shaft, chamber with wings and lower casing to the upper casing. Fasten the upper casing in a clamp, insert the cotter bolt and O ring seal, oil the surfaces.
7. Fit the screws and tighten them to the right tension. (See table). Should the bolts be of different lengths, put the shortest under the hose protector.
8. Test the rotator. Close the shafts O channel with a stopper and connect the hydraulic pressure hose to the O channel of the upper casing. Increase the pressure and turn the shaft. The shaft must be able to move freely.
9. Connect the hydraulic pressure hoses to the swivel channels in the upper casing, rotate the shaft by hydraulics. The shaft must be able to revolve smoothly.
10. Fit the nipples and hose protection.