

Ordering Code: **RD-08W-X-Y-Z**

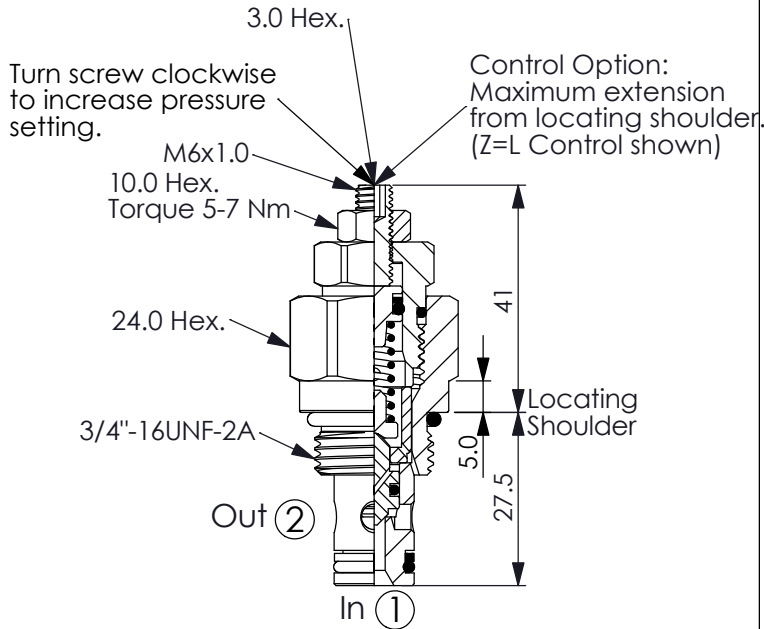

UNIT:mm

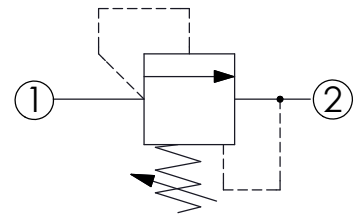
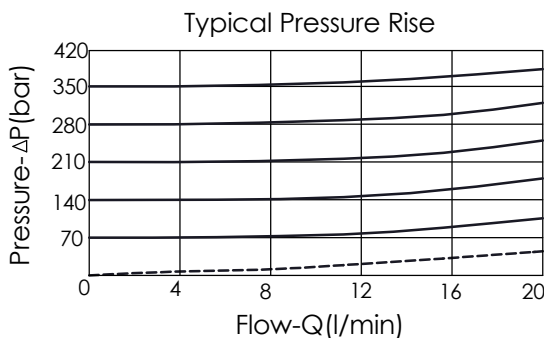

TECHNICAL DATA

Max. Operating pressure:	350 bar
Rated flow:	20 l/min
Cavity-Tooling:	08W-2
Installation torque:	25-35 Nm
Weight:	0.11 (Z=L) kg
Will accept maximum pressure at port ②; suitable for use in cross port relief circuits.	

X OPERATION

20 ① to ② (P to T)

- Response Time-Typical (2 ms)
- Maximum Leakage Approximately (5 drops/min. to 85% of nominal setting)
- Dirt tolerant
- This valve cannot limit max. pressure adjustment
- If you would like to assemble with other knob (for example, Z option= K, T), please kindly choose RD08W20-~~Y~~Z-A
- Because this valve is designed to save space, locking the screw thoroughly will cause damage to the internal structure, if you have this concern, please choose the valve with pressure limiting structure, For example: RD08W20-~~Y~~Z-A

Y PRESSURE SETTING

A	80-210 bar (140 bar Standard Setting)
D	30-55 bar (40 bar Standard Setting)
E	10-28 bar (14 bar Standard Setting)
K	40-155 bar (70 bar Standard Setting)
W	150 -350 bar (210 bar Standard Setting)

Z OPTIONS

L Leakproof hex. socket screw.



F Handknob and locknut.

