

### Dimensions

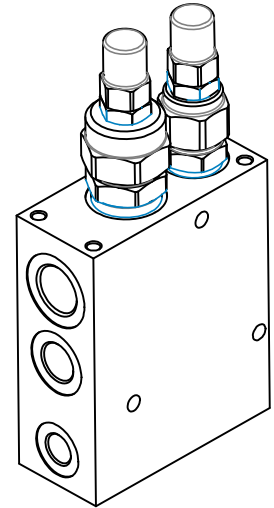

### Hydraulic Symbol

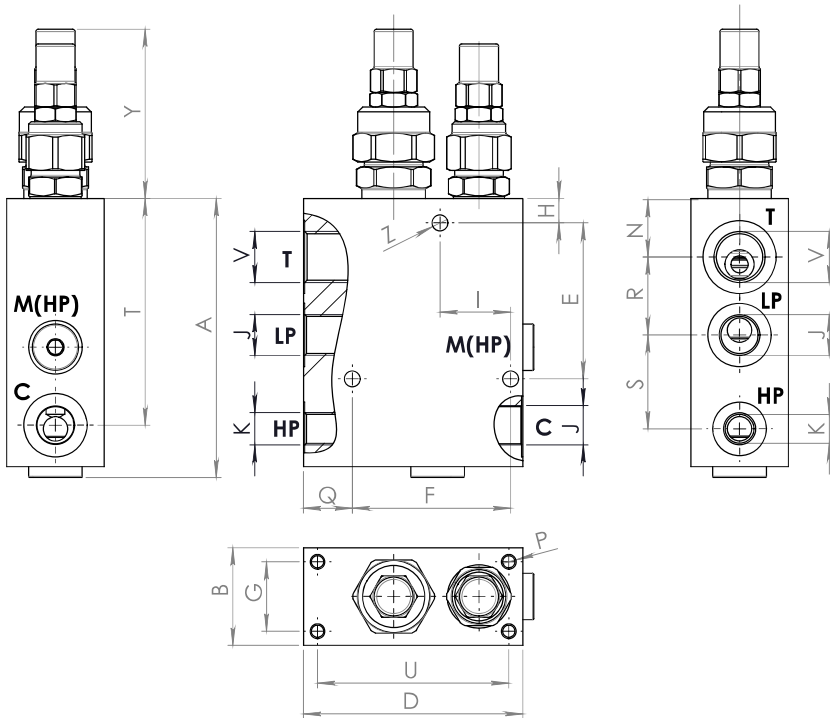
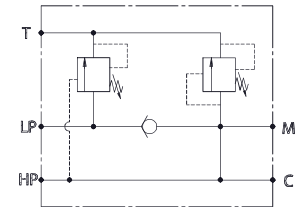

Size	A	B	D	E	F	G	H	I	J BSP	K BSP	V BSP	N	P	Q	R	S	T	U	Y	Z	Weight kg
02	110	40	90	64	65	28,5	10	29	3/8	1/4	1/2	22	M6	20	36	36	94,5	78,5	69,5	6,5	2,42
03	110	40	90	64	65	28,5	10	29	1/2	3/8	3/4	22	M6	20	36	36	94,5	78,5	69,5	6,5	2,10
04	125	50	110	65	80	38	10	37	3/4	1/2	1	22	M6	25	43	40	101	98	72	6,5	5,15

### Curves

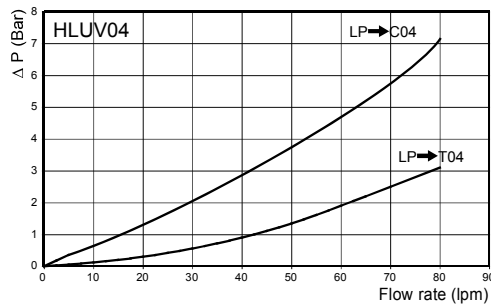
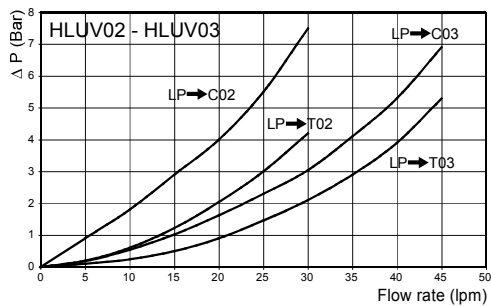

### Features

SIZE	02	03	04
Max Pressure (bar)	350	350	350
Max Flow Rate LP $\square$ C (lpm)	30	45	80

**Materials:** Zinc plated steel cartridge, hardened steel inner parts.  
Steel manifold.

### Ordering Code

**HLUV**    --    --    --

Port Size BSP	LP - Spring (bar)		
	02	03	04
02	3/8		
03	1/2	10	20
04	3/4	10	20

HP - Spring (bar)	LP - Spring (bar)		
	02	03	04
20	40-210	40-210	20-260
30	100-350	100-350	120-350

**Ordering Code Example: HLUV032030** = Hi-Low 1/2 BSP, LP valve 20-260 bar, HP valve 100-350 bar.