



HIDROMAS
YOUR GLOBAL TIPPING PARTNER

OIL COOLER

SYSTEMS



OGÓLNE INFORMACJE O PRODUKCIE

Materiał główny	: Aluminium
Materiał wentylatora/osłony	: Metal lub twardy plastik
Maks. temperatura pracy	: 120°C
Ciśnienie próbne	: 30 Bar
Ciśnienie robocze	: 20 Bar
Obszary zastosowania	: Mobilne i stacjonarne

Chłodnice GHS służą do chłodzenia oleju w układzie hydraulicznym poprzez przepuszczanie powietrza otoczenia przez rdzeń za pomocą wentylatora / silnika elektrycznego lub hydraulicznego. Dzięki właściwościom żeberek chłodzących zwiększa się turbulencja płynu, a tym samym zdolność wymiany ciepła. Dodatkowo specjalne struktury w żeberkach chłodzących zwiększają całkowity współczynnik przewodzenia. Jest to produkt kompaktowy, lekki, wytrzymały i nowoczesny.

MONTAŻ

W celu utrzymania naturalnego przepływu powietrza chłodnice mogą być montowane poziomo (**rys. 1**). Zazwyczaj montuje się je w przewodach powrotnych zbiornika oleju. Należy chronić je przed nagłymi zmianami ciśnienia i uderzeniami. Zalecamy zainstalowanie zaworu obejściowego w celu ochrony chłodnicy przed nieprzewidzianym wysokim ciśnieniem (**rys. 2**).

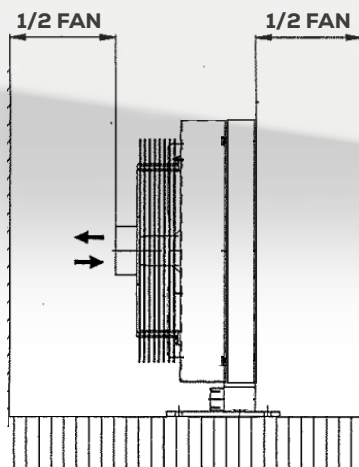

RYS. 1
SCHEMA-1

GENERAL PRODUCT INFORMATION

Main Material	: Aluminium
Fan / Fan Protection Material	: Metal or Rigid Plastic
Maximum Operating Temperature	: 120°C
Test Pressure	: 30 Bar
Operating Pressure	: 20 Bar
Application Areas	: Mobile and Stationary Industrial Applications

HIDROMAS air-oil heat exchangers are used to cool the oil in the hydraulic system by passing the surrounding air through the cores via fans/electric motors. Thanks to the features of the cooling fins, it increases the fluid's turbulence and, therefore, the heat exchange capacity. Additionally, the special structures in the cooling fins increase the overall heat transfer coefficient. It is a compact, lightweight, durable, and technological product.

INSTALLATION

In order to maintain natural air flow, radiators can be installed horizontally, paying attention to the minimum distance between and the wall. (**Schema-1**) Heat exchangers are typically installed in the return tubes of the oil reservoir in the system. It should be protected from impacts and mechanical vibrations with supports and connected to the system with flexible tubes. We recommend installing a bypass valve to protect the radiator from unforeseen high pressure that may occur when the system is operating. (**Schema-2**)

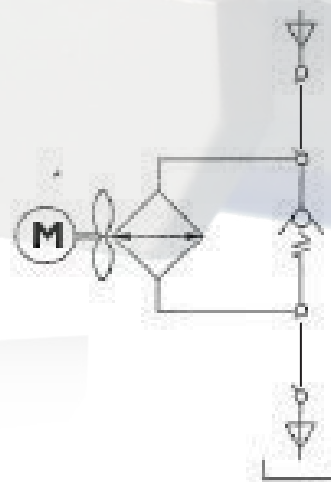

RYS. 2
SCHEMA-2

KONSERWACJA

Podczas czyszczenia części chłodnicy należy zachować ostrożność, aby zapewnić sprawność cieplną i wymianę ciepła.

CZYSZCZENIE

Zanieczyszczenia można usuwać środkiem odtłuszczającym zgodnym z aluminium. Stronę powietrzną można czyścić sprężonym powietrzem lub wodą.

Przed czyszczeniem należy odłączyć zasilanie wentylatora.

DOBÓR CHŁODNICY

Znając podstawowe dane przedstawione w poniższym przykładzie, można dokonać wyboru wymiennika ciepła.

DANE:

Moc rozpraszania : 12 KW

Przepływ oleju (ISO VG 32) : 90 lpm

Temperatura wlotu oleju : 80°C

Temperatura otoczenia : 40°C

Wentylator napędzany silnikiem elektrycznym 230/400V-50Hz.

Na podstawie danych: moc rozpraszania, różnica temperatur ΔT (między temperaturą oleju a temperaturą otoczenia) można obliczyć specyficzną moc wymiany ciepła w kW/°C.

$$P = \frac{12 \text{ KW}}{80^{\circ}\text{C} - 40^{\circ}\text{C}} = 0.30 \text{ KW} / ^{\circ}\text{C}$$

Wybór urządzenia odbywa się na podstawie wydatku oleju (**l/min**) i mocy wymiany ciepła, odnosząc się do wykresów katalogowych.

MAINTENANCE

Care should be taken when cleaning the parts of the cooler to ensure thermal efficiency and heat exchange with natural air.

CLEANING

Dirt can be washed away with a counter-current degreasing agent compatible with aluminum.

Cleaning the air side can be done using pressurized air or water. During cleaning, the electrical connection of the fan motor must be disconnected.

HEAT EXCHANGER SELECTION

By knowing the basic data shown in the example below, you can make a selection for the heat exchanger.

THE DATA:

Dissipate Power : 12 KW

Oil Flow Rate (ISO VG 32) : 90 lpm

Oil Inlet Temperature : 80°C

Ambient Temperature : 40°C

The fan powered by an electric motor is 230/400V-50Hz.

Based on this data, if you know the distribution power ΔT (the difference between the oil inlet temperature and the ambient temperature), you can calculate the specific heat exchange power in kW/°C.

$$P = \frac{12 \text{ KW}}{80^{\circ}\text{C} - 40^{\circ}\text{C}} = 0.30 \text{ KW} / ^{\circ}\text{C}$$

The product selection is made based on the oil flow rate (**90 lpm**) and specific heat exchange power (**0.30 kW/°C**), referring to the graph of each product model in the catalog.

MODEL

GHSOC040
GHSOC080
GHSOC100
GHSOC120
GHSOC140
GHSOC160
GHSOC180
GHSOC220

SILNIK WENTYLATORA

230V AC 50 Hz
380V AC 50 Hz
12V AC DC
24V AC DC

TERMOSTAT

40 / 45-40 °C
50 / 55-50 °C
55 / 60-55 °C
AT Termostat regulowany / Adjustable Thermostat
00 Bez termostatu / Without Thermostat

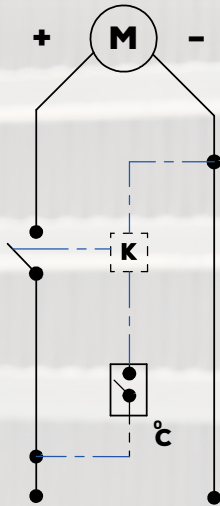
INSTALACJA ELEKTRYCZNA / ELECTRIC WIRING**12 - 24V DC INSTALACJA ELEKTRYCZNA**
12 - 24V DC ELECTRIC WIRING

K : PRZEKAŹNIKA / RELAY
C : TERMOSTAT / THERMOSTAT

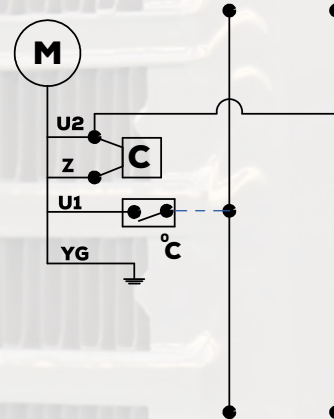
230V AC JEDNOFAZOWA INSTALACJA ELEKTRYCZNA
230V AC MON. ELECTRIC WIRING

YG : UZIEMIENIE / GROUND
U1 : NIEBIESKI / BLUE
U2 : CZARNY / BLACK
Z : BRĄZOWY / BROWN
C : KONDENSATOR / CAPACITOR
C : TERMOSTAT / THERMOSTAT

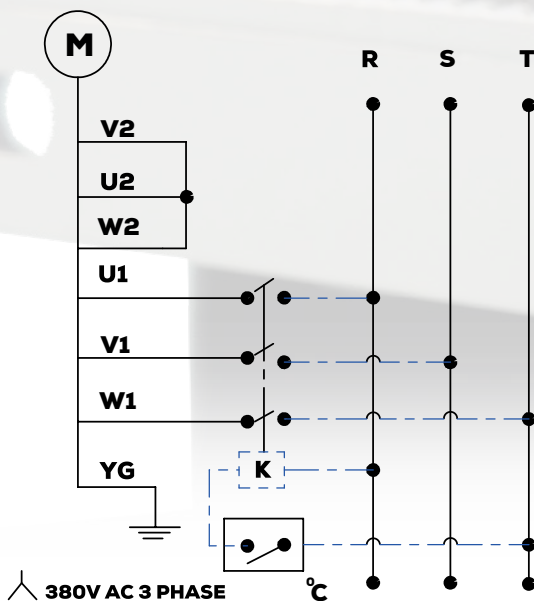
380V AC TRÓJFAZOWA INSTALACJA ELEKTRYCZNA
380V AC THREEPHASE ELECTRIC WIRING

U1 : CZARNY / BLACK
V1 : NIEBIESKI / BLUE
W1 : BRĄZOWY / BROWN
YG : UZIEMIENIE / GROUND
C : TERMOSTAT / THERMOSTAT

U2 : ZIELONY / GREEN
V2 : BIAŁY / WHITE
W2 : ŻÓŁTY / YELLOW
K : PRZEKAŹNIK / RELAY

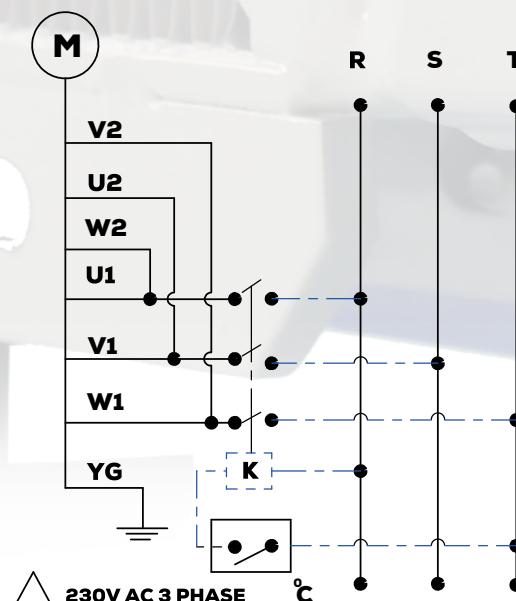
230V AC TRÓJFAZOWA INSTALACJA ELEKTRYCZNA
230V AC THREEPHASE ELECTRIC WIRING

U1 : CZARNY / BLACK
V1 : NIEBIESKI / BLUE
W1 : BRĄZOWY / BROWN
YG : UZIEMIENIE / GROUND
C : TERMOSTAT / THERMOSTAT

U2 : ZIELONY / GREEN
V2 : BIAŁY / WHITE
W2 : ŻÓŁTY / YELLOW
K : PRZEKAŹNIK / RELAY

SCHEMAT PODŁĄCZENIA / ASSEMBLY

Przyłącze termostatu
Thermostat Connection

Wylot oleju
Oil Outlet

Wejście oleju
Oil Inlet

Korek spustowy oleju
Oil Drain Plug

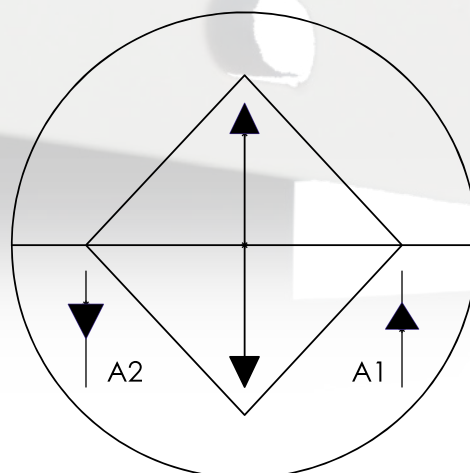
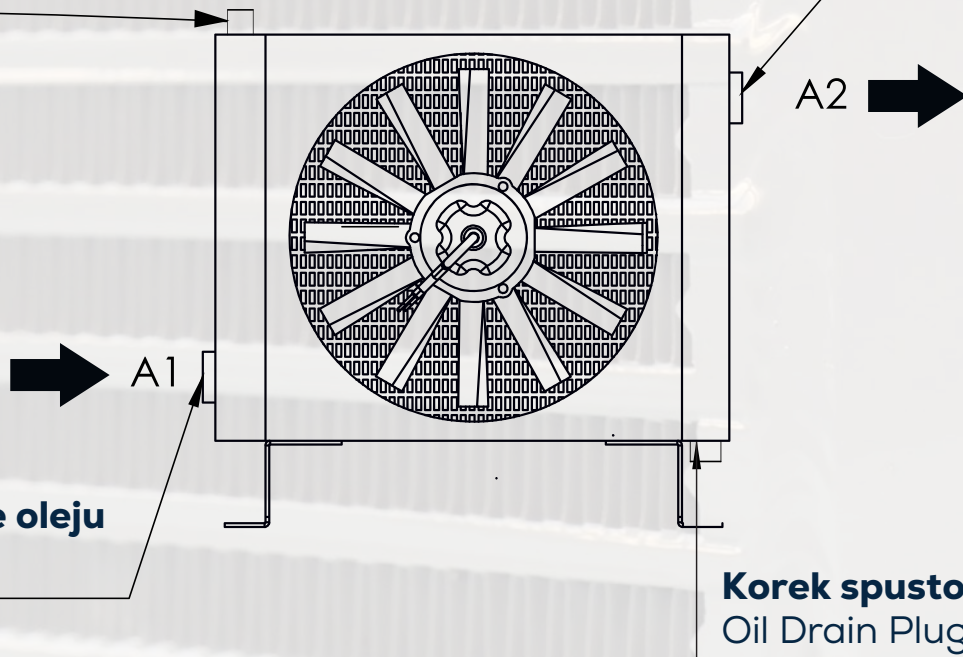

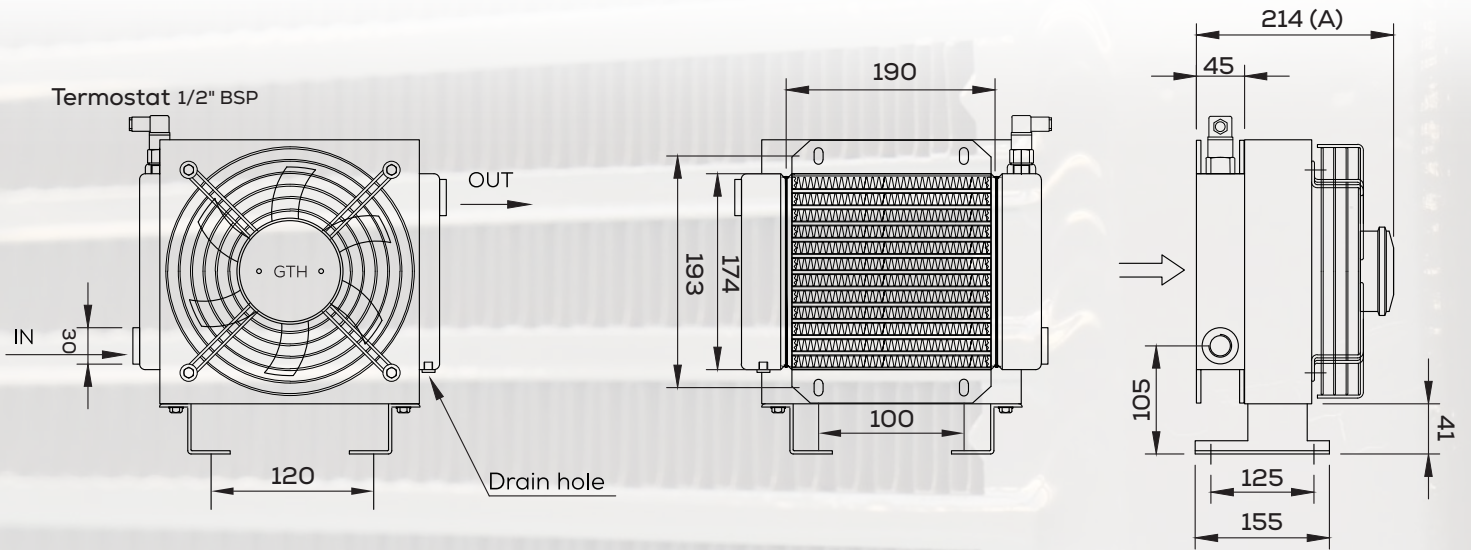

GHSOC040-230
GHSOC040-380

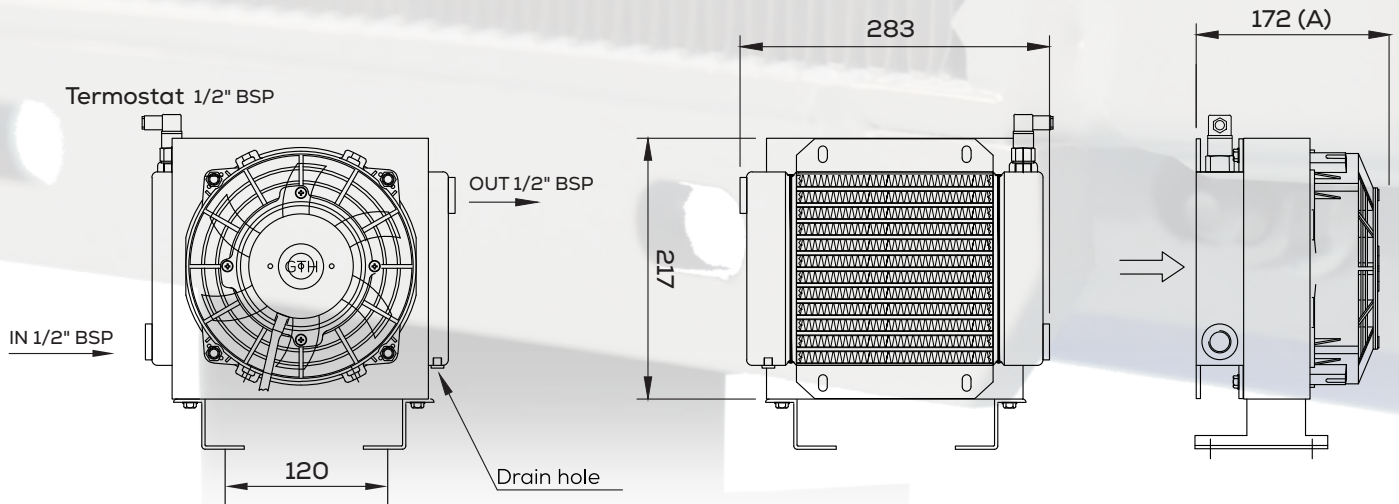

GHSOC040-012
GHSOC040-024

GHSOC040	Fan ø	Voltage V	Frequency Hz	Current A	kW(W)	rpm	m³/h	dB(A)	IP
024	190	24V	/	3.0A	0.08	3500	400	60-70	68
012	190	12V	/	6.0A	0.08	3600	400	60-70	68
230	172	230	50	0.22A	0.38	2500	560	48	54
380	172	380	50	0.18A	0.38	2500	530	45	54
HM	Please contact for the Hydraulic Motor variant								

Performance Diagram

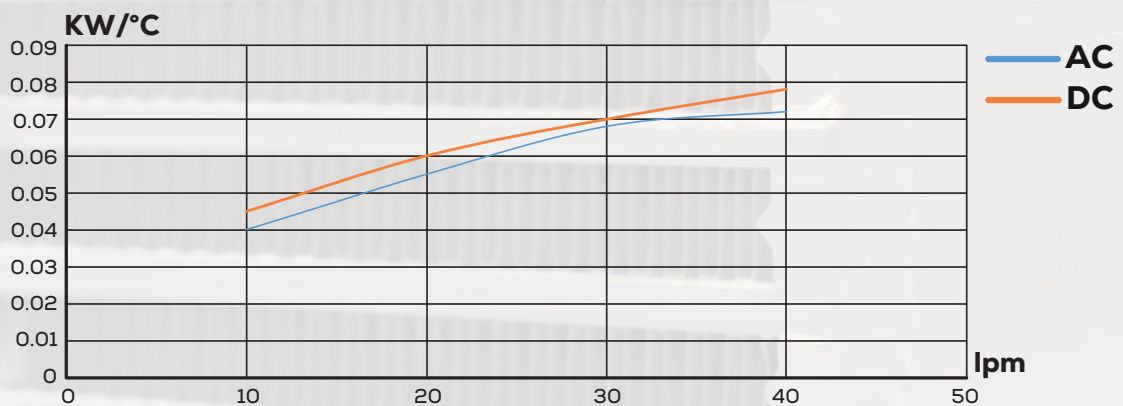

Pressure Drop

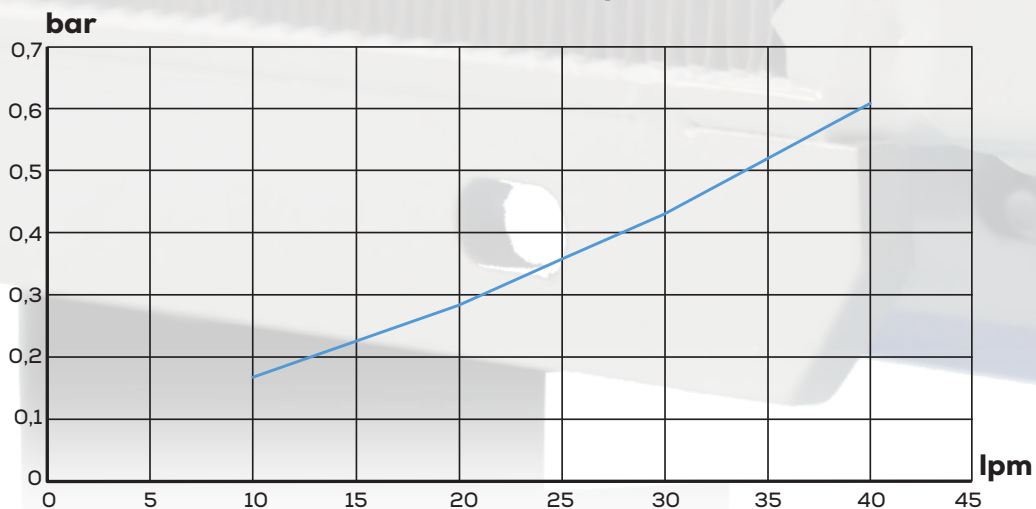

Correction Factor -F- (pressure drop)

cst	10	15	20	30	40	50	60	80	100	200	300
F	0,5	0,65	0,76	1	1,21	1,4	1,6	1,9	2,1	3,4	4,3

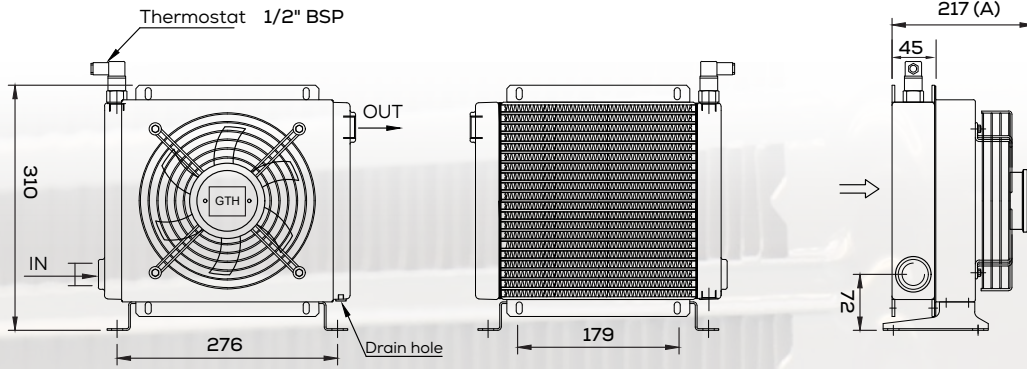

GHSOC080-230
GHSOC080-380

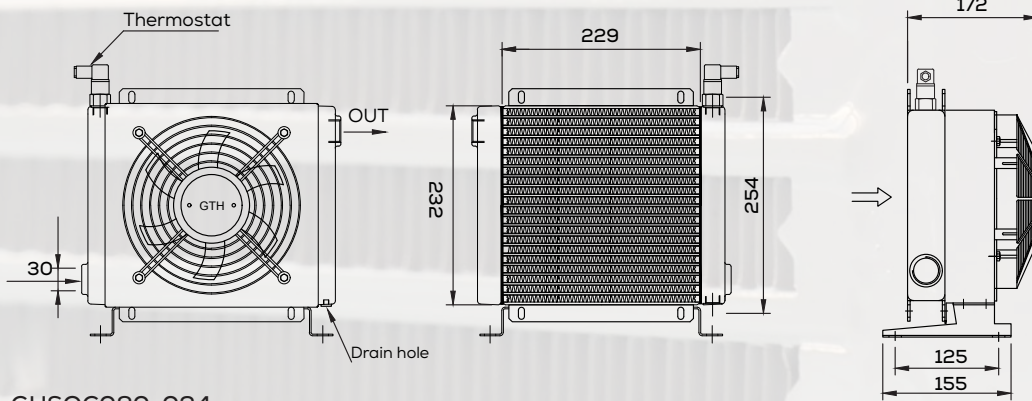

GHSOC080-024
GHSOC080-012

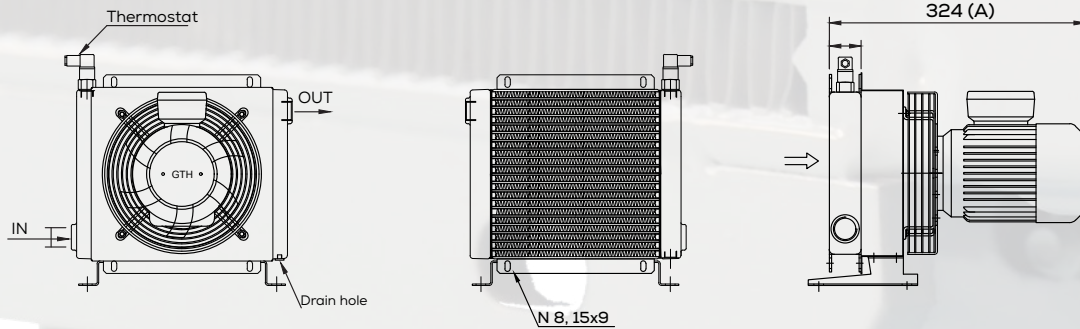

GHSOC040-B14

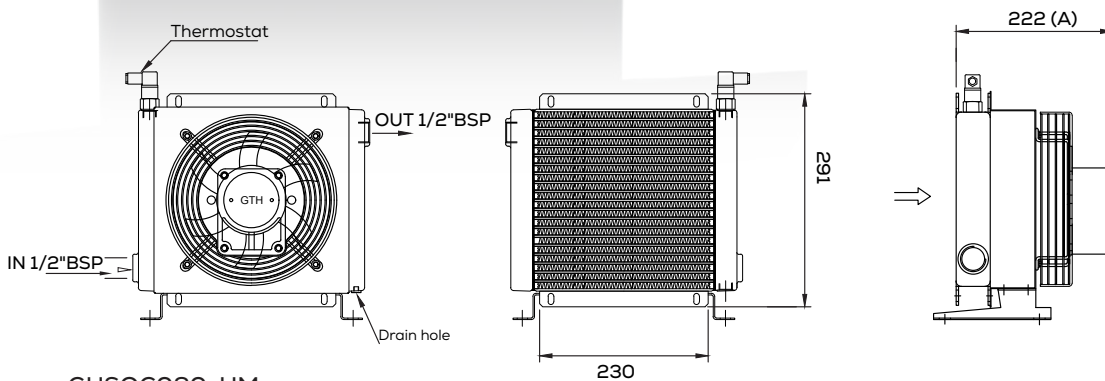

GHSOC080-HM

GHSOC080	Fan ø	Voltage V	Frequency Hz	Current A	kW(W)	rpm	m³/h	dB(A)	IP
024	190	24V	/	3.0A	0.08	3500	400	60-70	68
012	190	12V	/	6.0A	0.08	3600	400	60-70	68
230	200	230	50	0.42A	0.08	2500	795	52	54
380	200	380	50	0.37A	0.08	2500	760	50	54
B14	200	230-400 AC B14	50	0.75A	0.25	1380	340	54	55
HM	Please contact for the Hydraulic Motor variant								

Performance Diagram

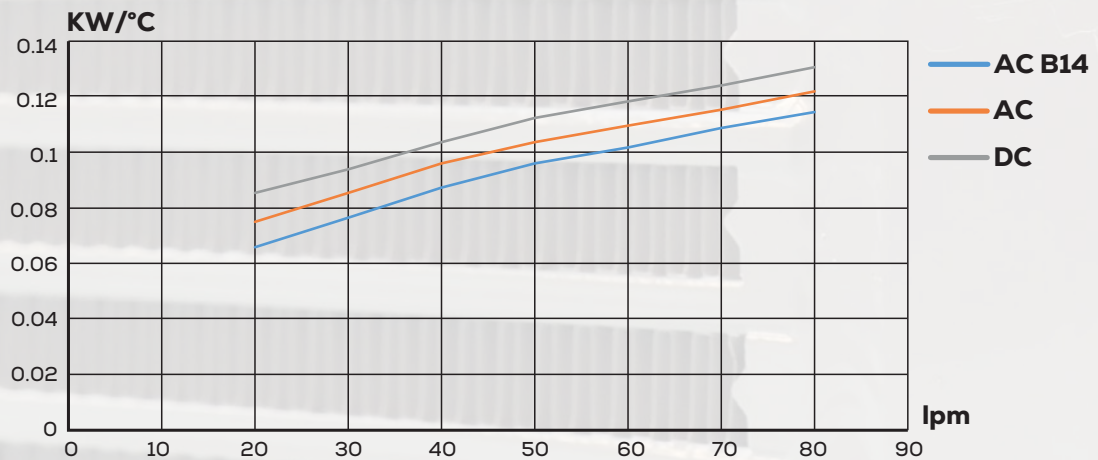

Pressure Drop

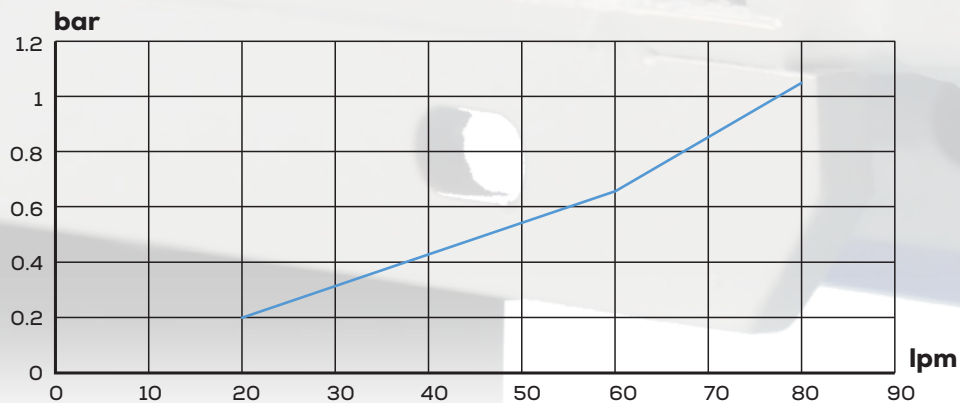

Correction Factor -F- (pressure drop)

cst	10	15	20	30	40	50	60	80	100	200	300
F	0,5	0,65	0,76	1	1,21	1,4	1,6	1,9	2,1	3,4	4,3

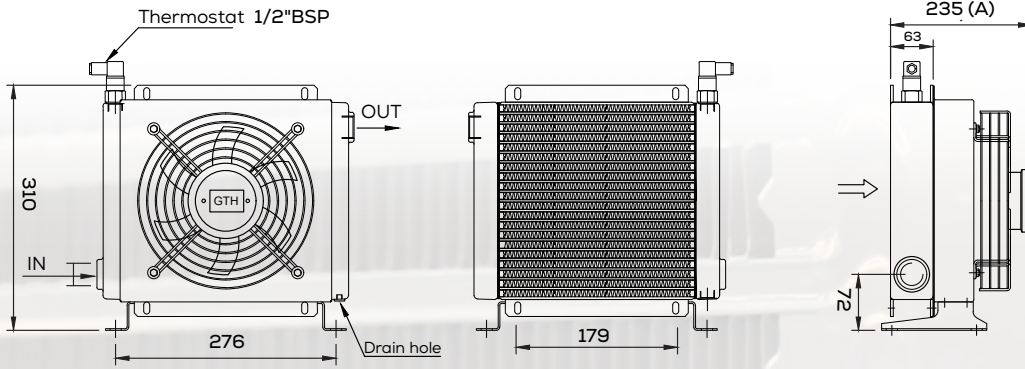

GHSOC100-230
GHSOC100-380

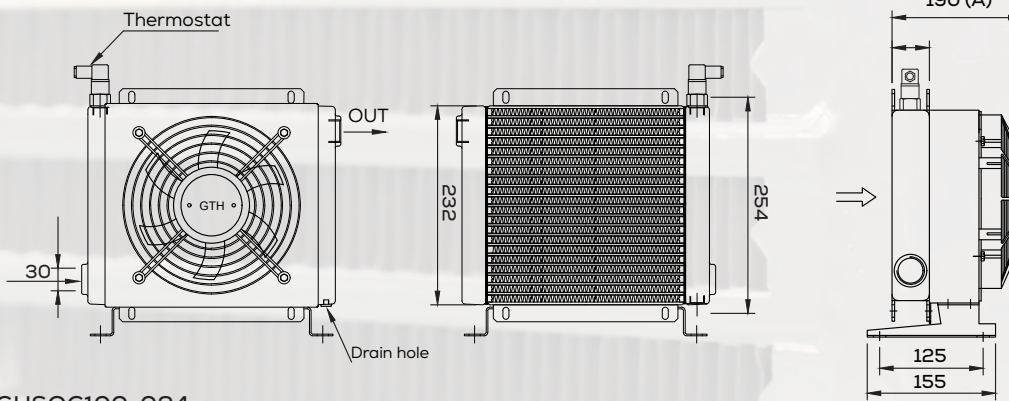

GHSOC100-024
GHSOC100-012

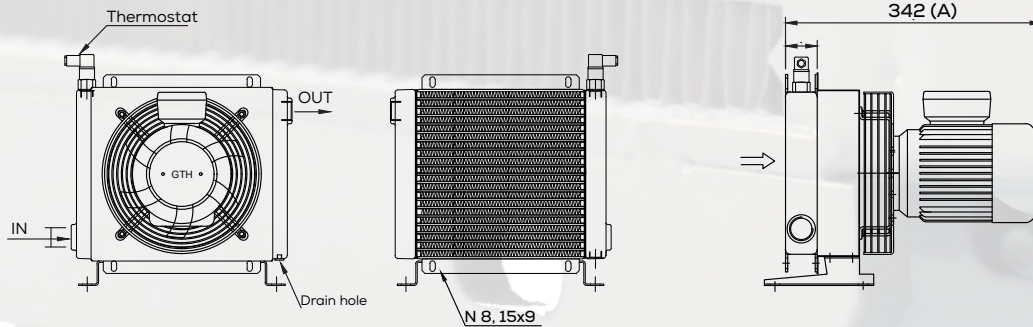

GHSOC100-B14

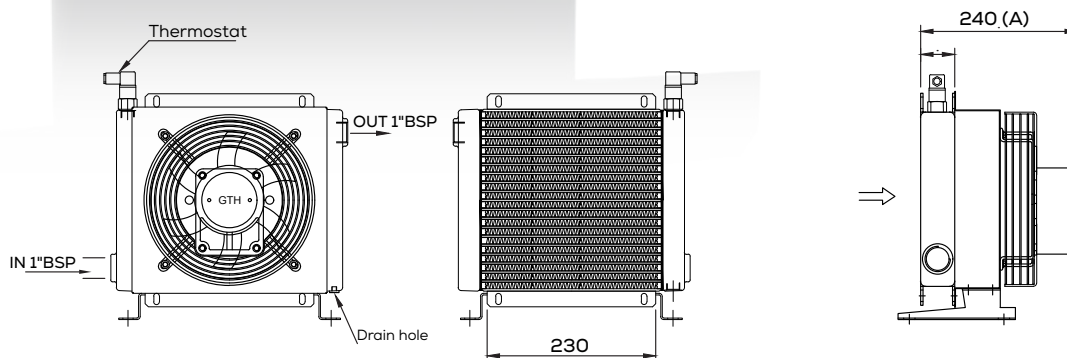

GHSOC100-HM

GHSOC100	Fan ø	Voltage V	Frequency Hz	Current A	kW(W)	rpm	m ³ /h	dB(A)	IP
024	190	24V	/	3.0A	0.08	3500	400	60-70	68
012	190	12V	/	6.0A	0.08	3600	400	60-70	68
230	200	230	50	0.42A	0.08	2500	795	52	54
380	200	380	50	0.37A	0.08	2500	760	50	54
B14	200	230-400 AC B14	50	0.75A	0.25	1380	340	54	55
HM	Please contact for the Hydraulic Motor variant								

Performance Diagram

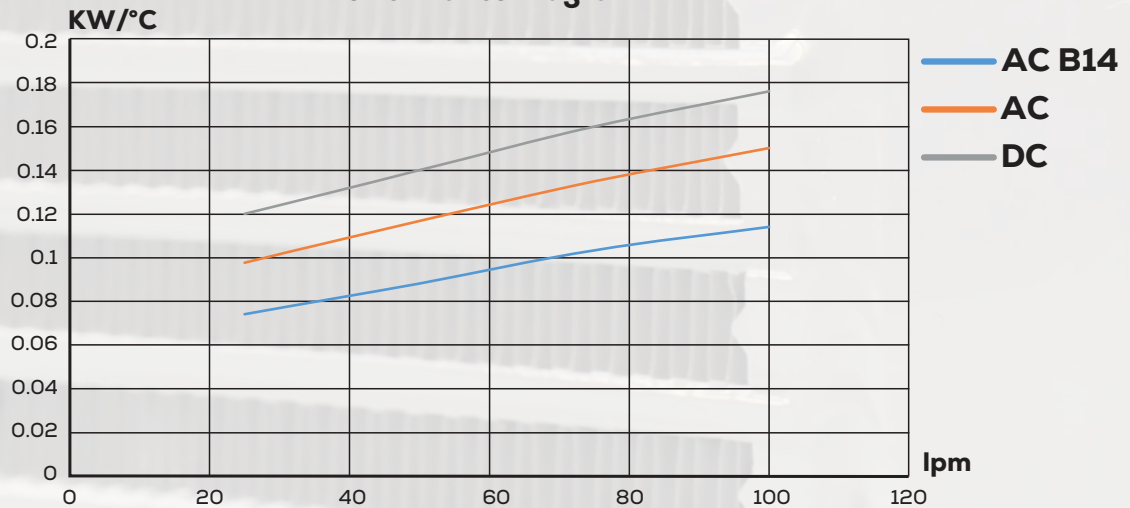

Pressure Drop

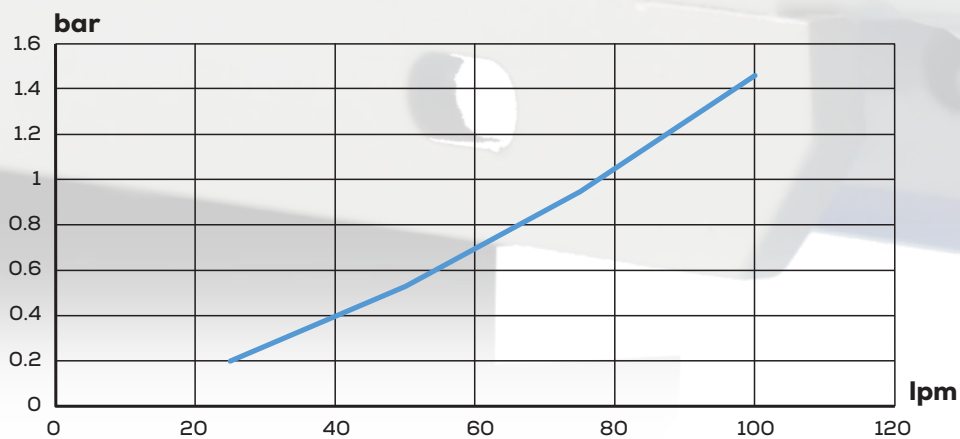

Correction Factor -F- (pressure drop)

cst	10	15	20	30	40	50	60	80	100	200	300
F	0,5	0,65	0,76	1	1,21	1,4	1,6	1,9	2,1	3,4	4,3

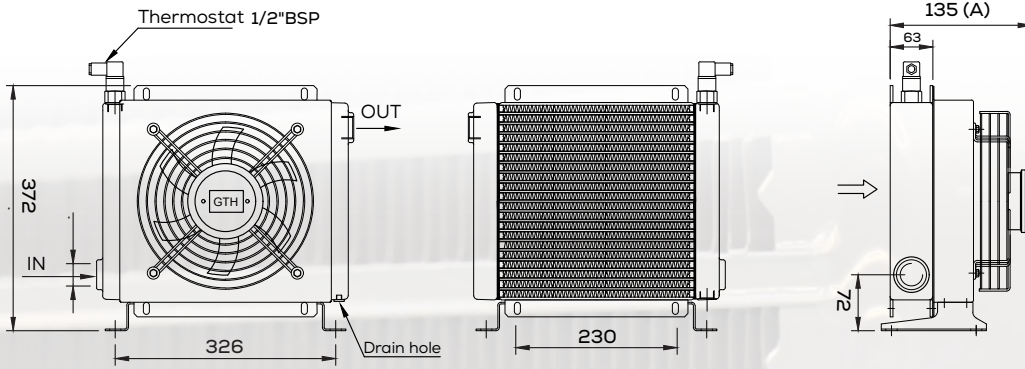

GHSOC120-230
GHSOC120-380

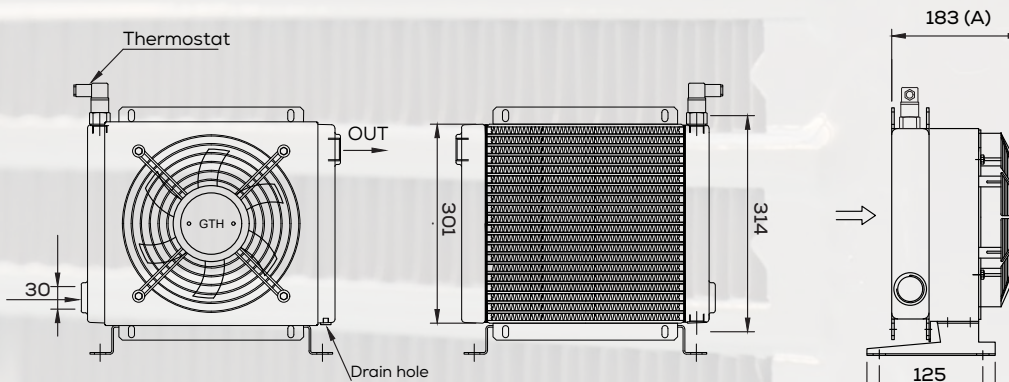

GHSOC120-024
GHSOC120-012

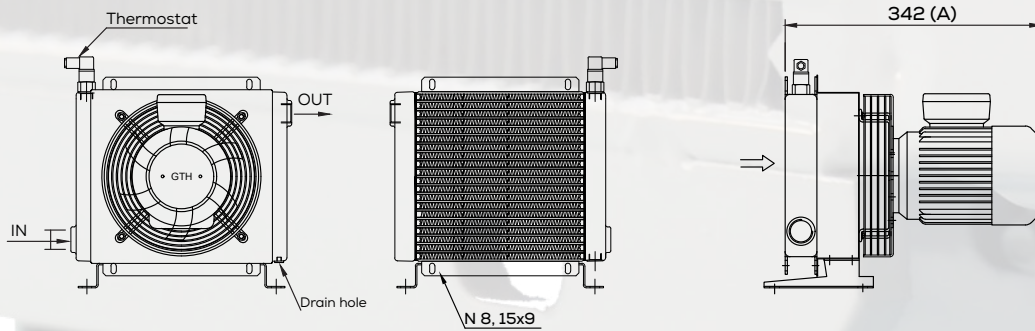

GHSOC120-B14

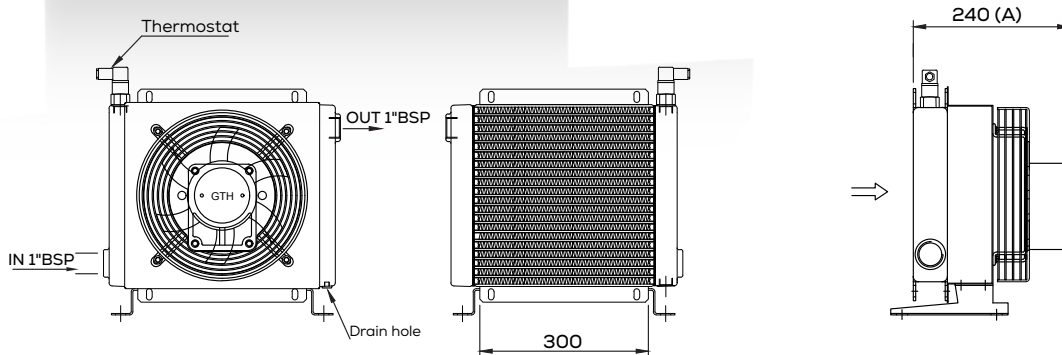

GHSOC120-HM

GHSOC120	Fan ø	Voltage V	Frequency Hz	Current A	kW(W)	rpm	m ³ /h	dB(A)	IP
024	254	24V	/	5.0A	0.12	3200	900	60-70	68
012	254	12V	/	10.0A	0.12	3200	900	60-70	68
230	250	230	50	0.45A	0.9	2500	1360	60	54
380	250	380	50	0.3A	0.9	2500	1300	59	54
B14	250	230-400 AC B14	50	0.75A	0.25	1380	340	54	55
HM	Please contact for the Hydraulic Motor variant								

Performance Diagram

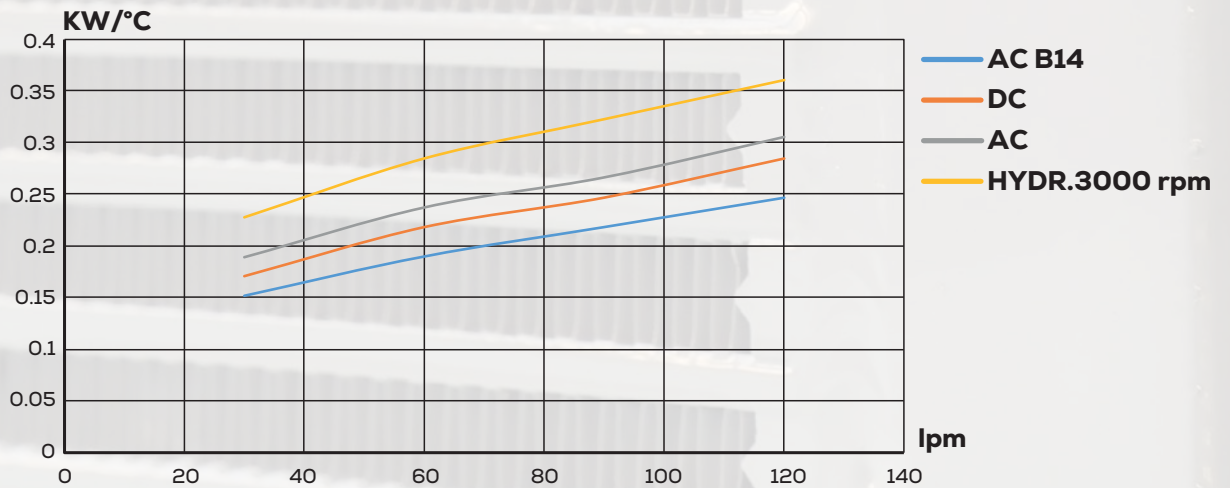

Pressure Drop

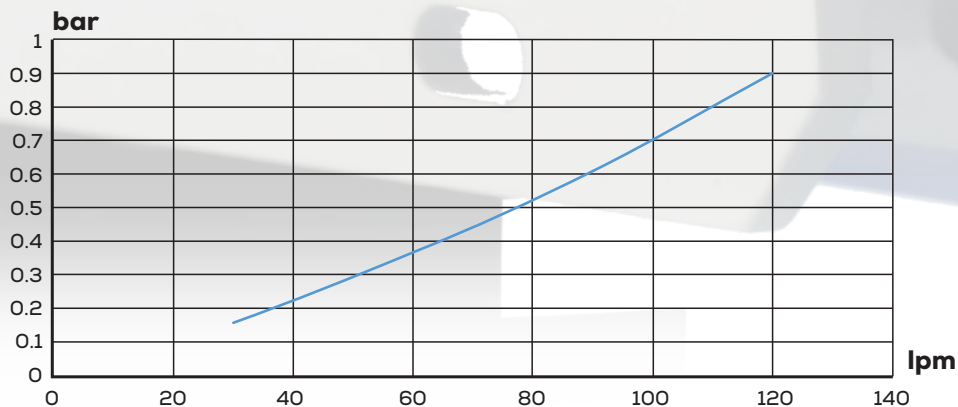

Correction Factor -F- (pressure drop)

cst	10	15	20	30	40	50	60	80	100	200	300
F	0,5	0,65	0,76	1	1,21	1,4	1,6	1,9	2,1	3,4	4,3

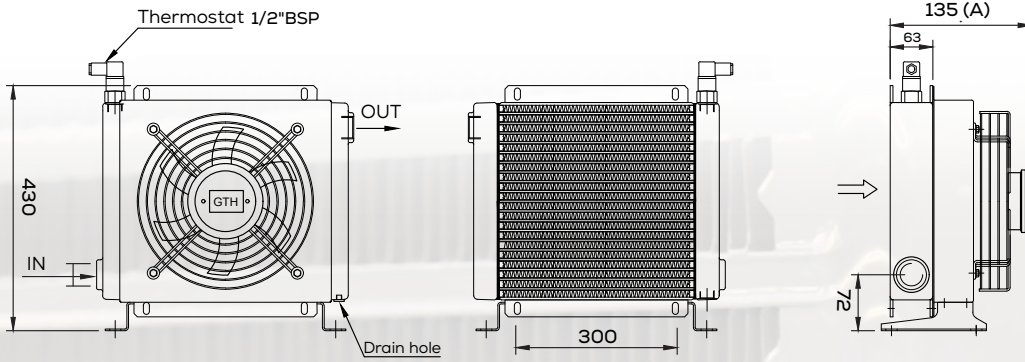

GHSOC140-230
GHSOC140-380

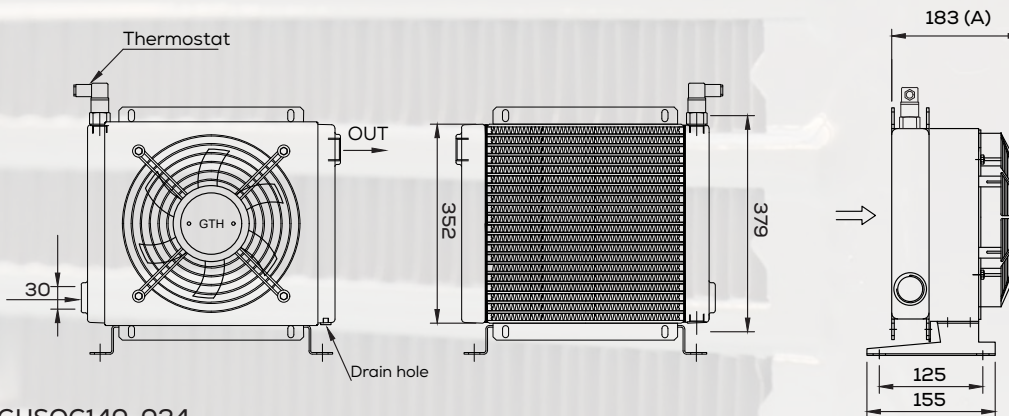

GHSOC140-024
GHSOC140-012

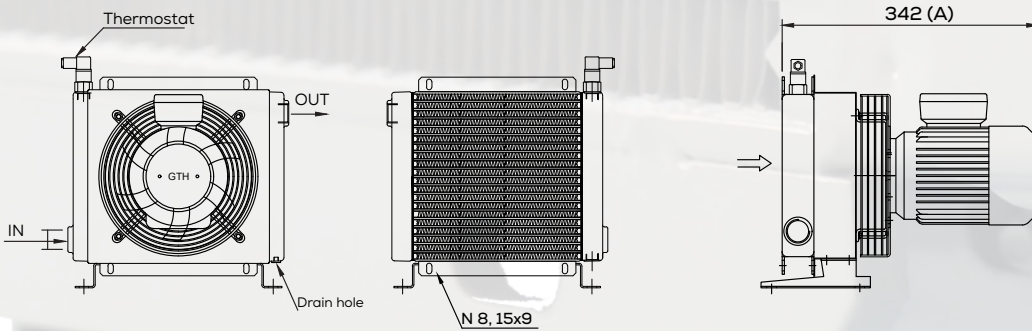

GHSOC140-B14

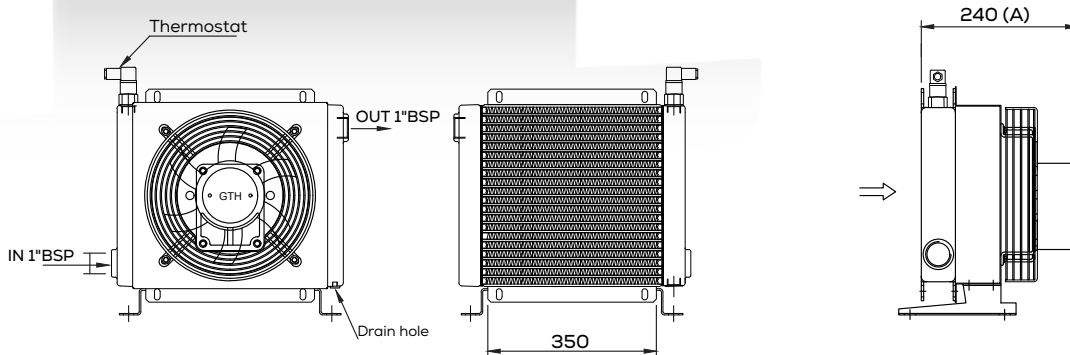

GHSOC140-HM

GHSOC140	Fan ø	Voltage V	Frequency Hz	Current A	kW(W)	rpm	m ³ /h	dB(A)	IP
024	304	24V	/	8.0A	0.18	2700	1200	60-70	68
012	304	12V	/	16.0A	0.18	2700	1200	60-70	68
230	300	230	50	0.65A	0.145	2500	2100	61	54
380	300	380	50	0.28A	0.145	2500	2300	62	54
B14	300	230-400 AC B14	50	1.10A	0.37	1390	1380	46	55
HM	Please contact for the Hydraulic Motor variant								

Performance Diagram

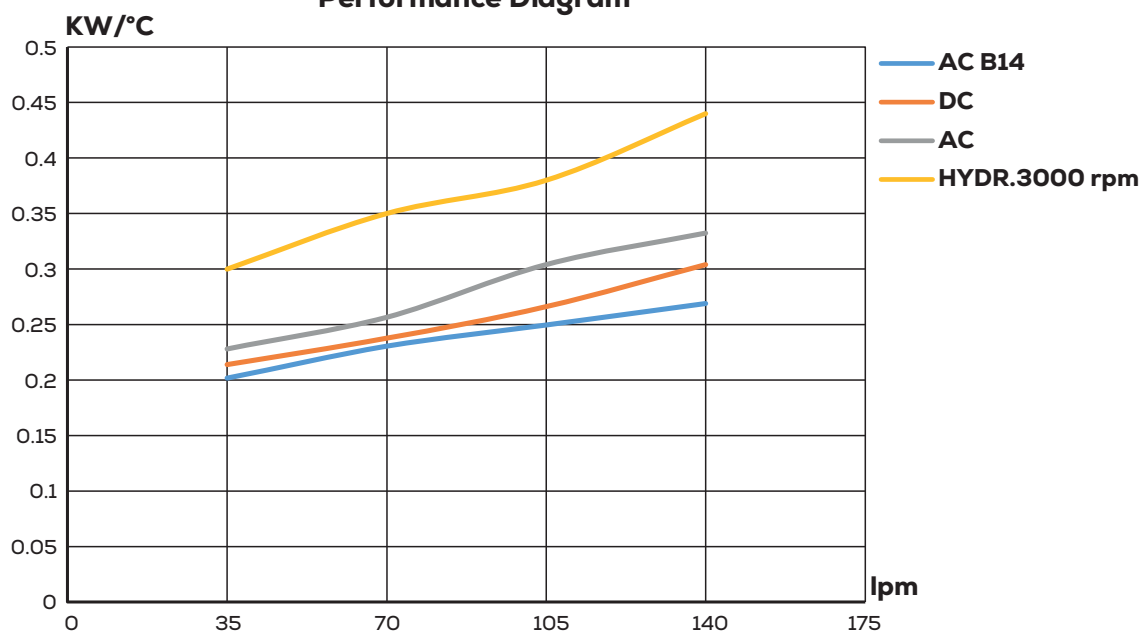

Pressure Drop

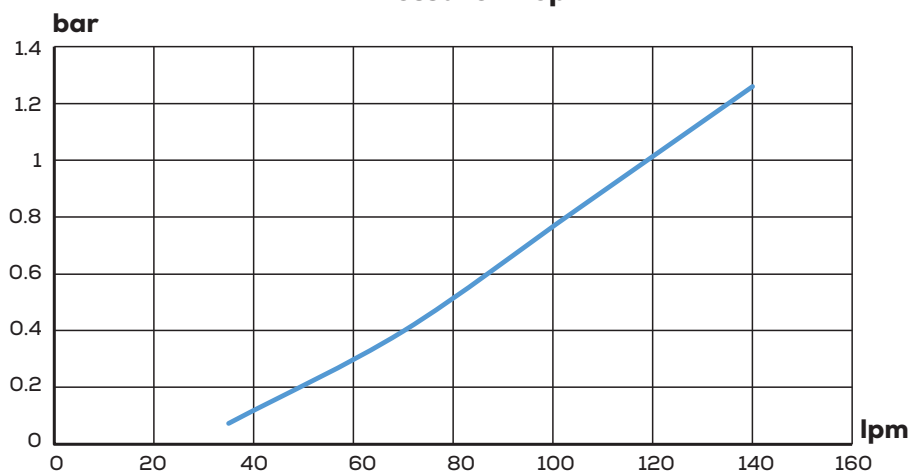

Correction Factor -F- (pressure drop)

cst	10	15	20	30	40	50	60	80	100	200	300
F	0,5	0,65	0,76	1	1,21	1,4	1,6	1,9	2,1	3,4	4,3

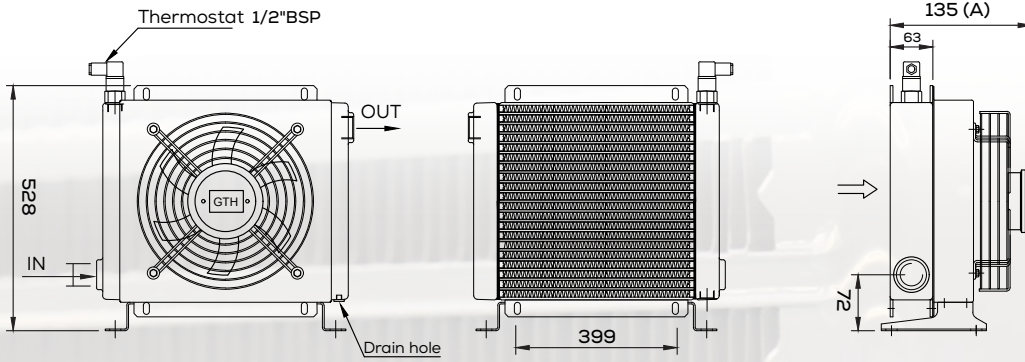

GHSOC160-230
GHSOC160-380

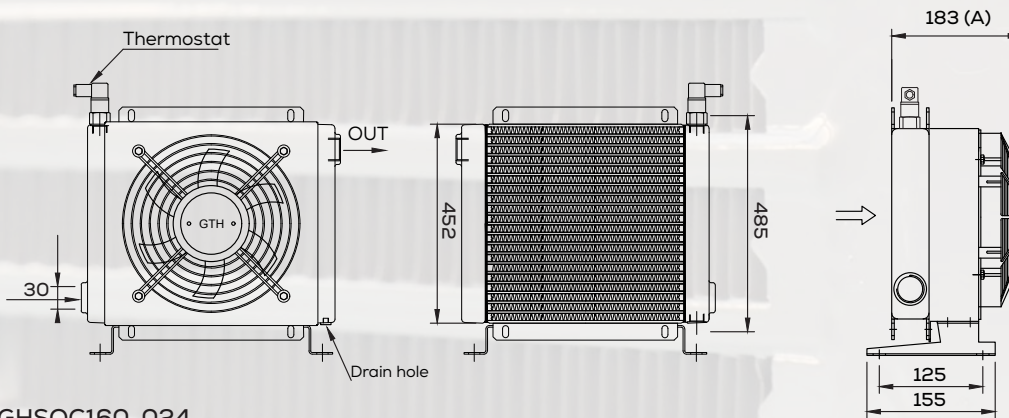

GHSOC160-024
GHSOC160-012

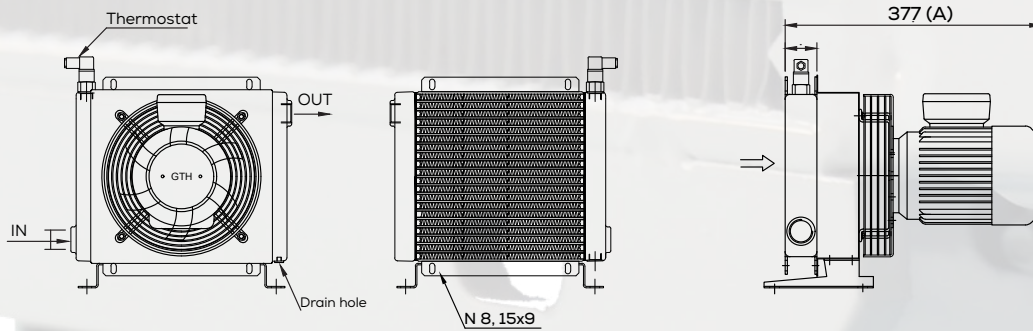

GHSOC160-B14

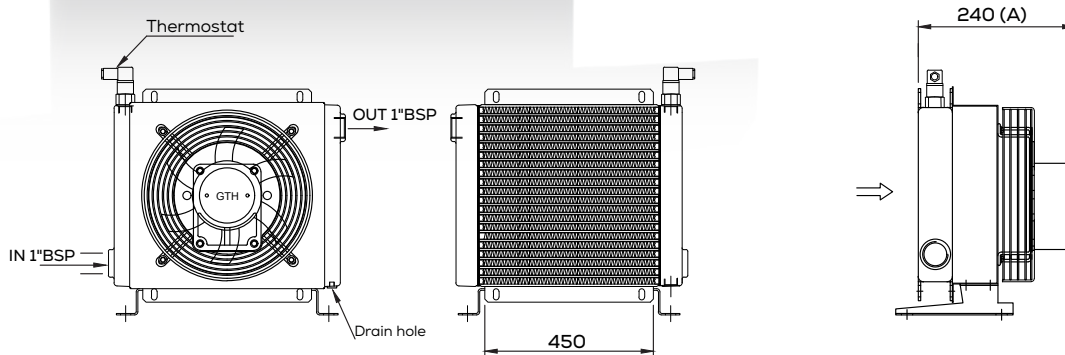

GHSOC160-HM

GHSOC160	Fan ø	Voltage V	Frequency Hz	Current A	kW(W)	rpm	m³/h	dB(A)	IP
024	355	24V	/	8.0A	0.22	2600	1700	60-70	68
012	355	12V	/	16.0A	0.22	2600	1700	60-70	68
230	350	230	50	0.45A	0.24	2500	5500	75	54
380	350	380	50	0.24A	0.112	2500	5300	73	54
B14	350	230-400 AC B14	50	1.45A	0.55	1365	3030	50	55
HM	Please contact for the Hydraulic Motor variant								

Performance Diagram

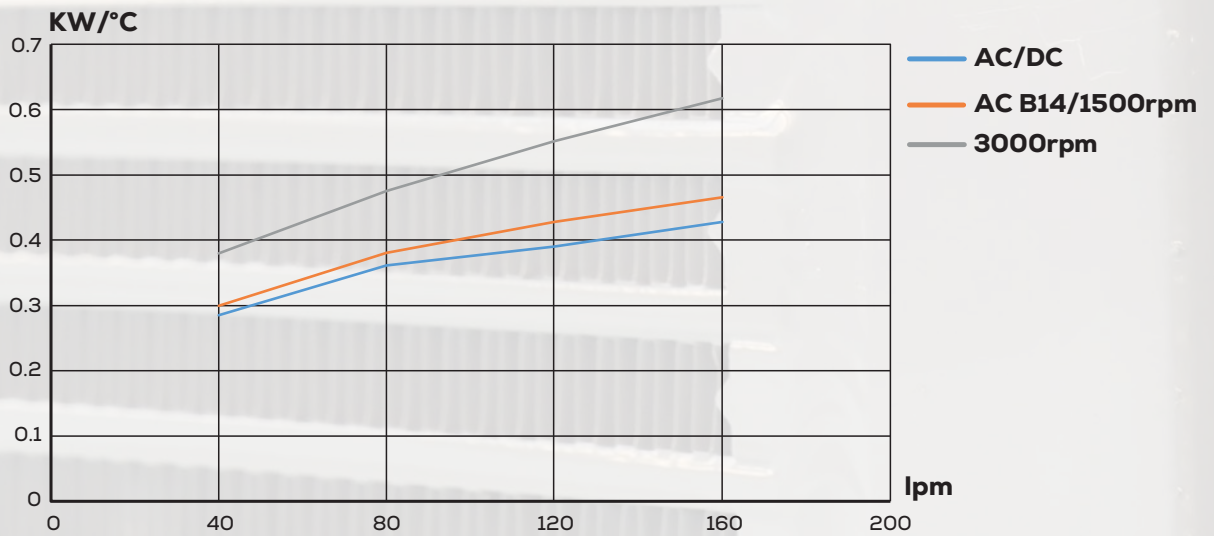

Pressure Drop

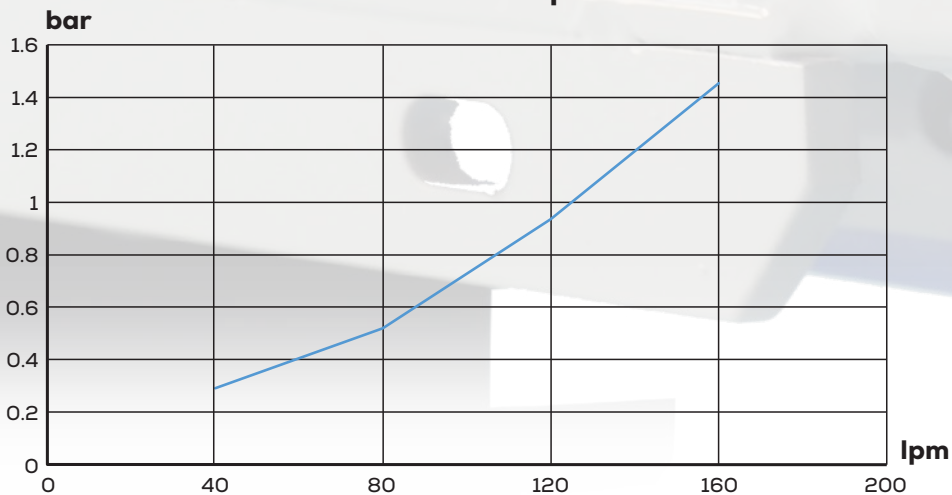

Correction Factor -F- (pressure drop)

cst	10	15	20	30	40	50	60	80	100	200	300
F	0,5	0,65	0,76	1	1,21	1,4	1,6	1,9	2,1	3,4	4,3

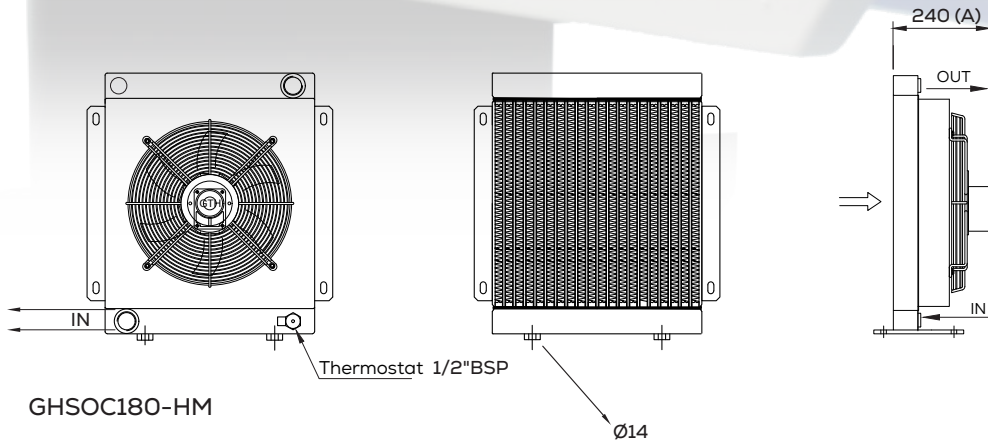
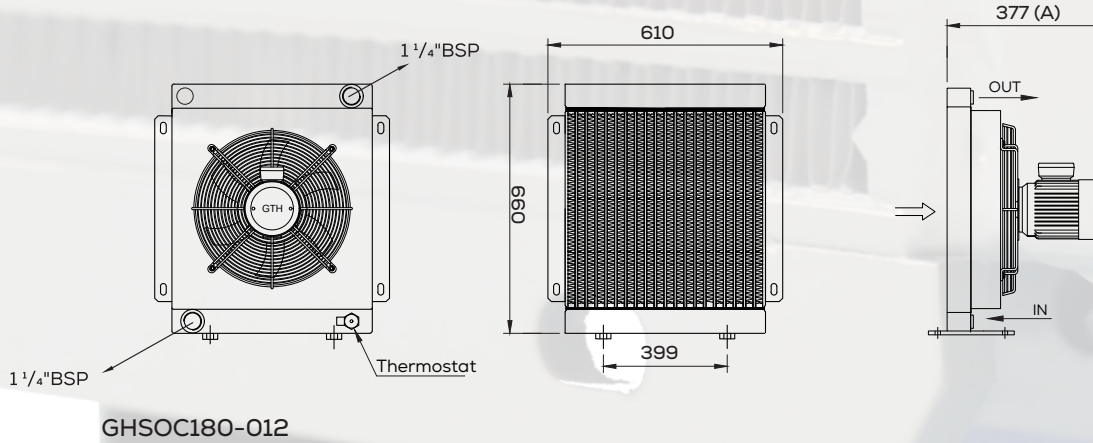
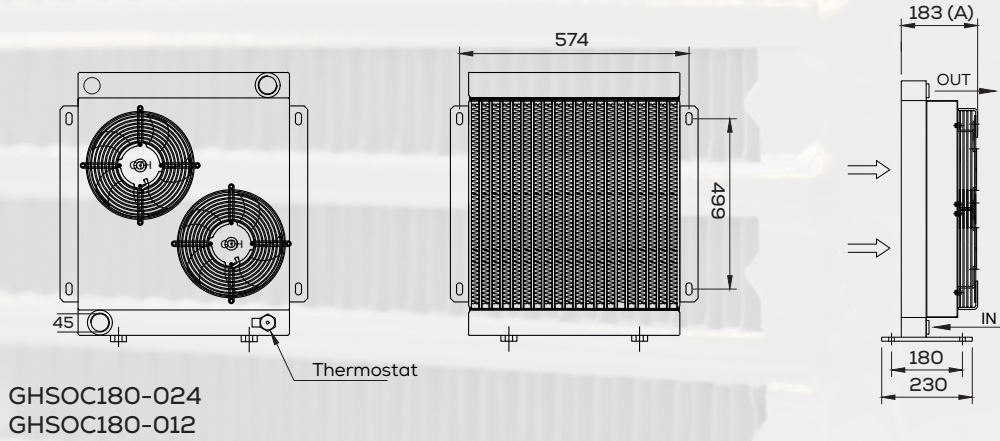
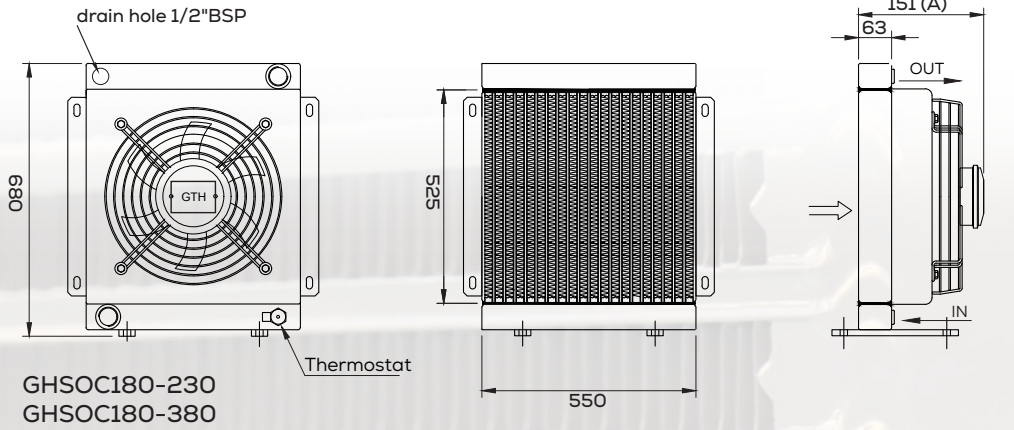

GHSOC180	Fan ø	Voltage V	Frequency Hz	Current A	kW(W)	rpm	m³/h	dB(A)	IP
024	254x2	24V	/	5.0A	0.12	3200	900	60-70	68
012	254x2	12V	/	10.0A	0.12	3200	900	60-70	68
230	250x2	230	50	0.4A	0.9	2500	1360	60	54
380	250x2	380	50	0.3A	0.9	2500	1300	59	54
230M	450	230	50	0.9A	0.205	1350	4350	67	54
380M	450	380	50	0.55A	0.205	1350	4390	68	54
B14	450	230-400 AC B14	50	2.0A	0.75	1410	4500	50	55
HM	Please contact for the Hydraulic Motor variant								

Performance Diagram

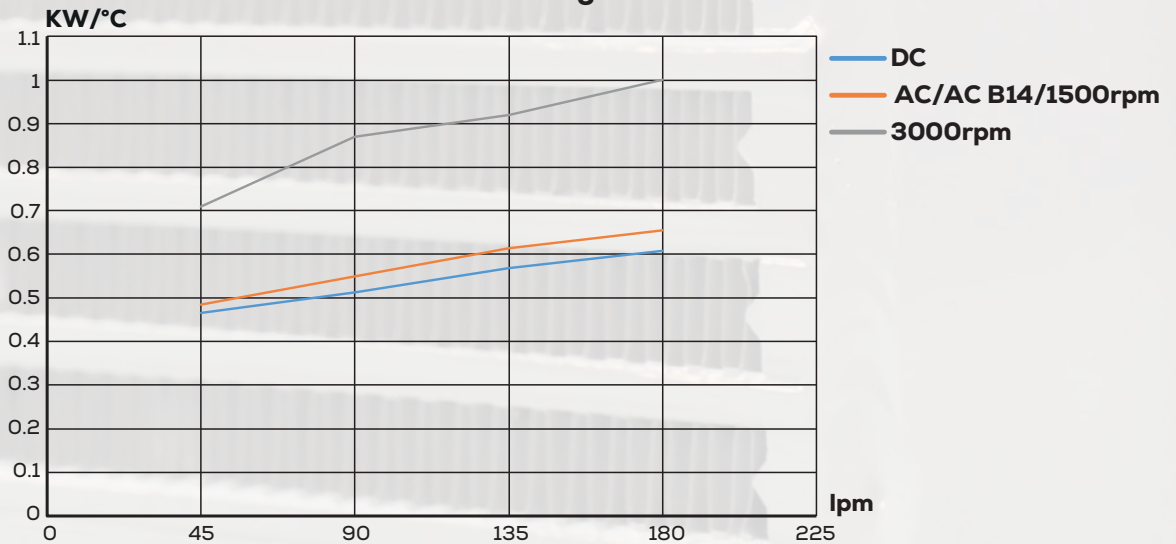

Pressure Drop

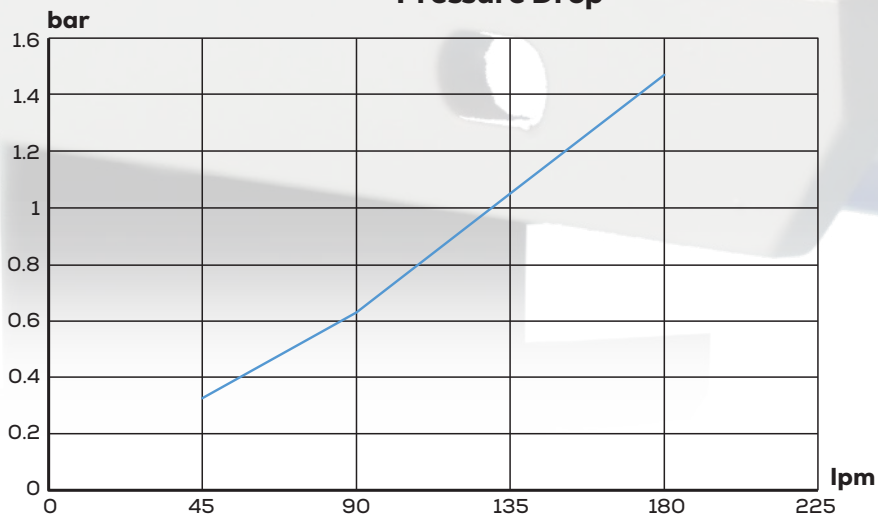

Correction Factor -F- (pressure drop)

cst	10	15	20	30	40	50	60	80	100	200	300
F	0,5	0,65	0,76	1	1,21	1,4	1,6	1,9	2,1	3,4	4,3

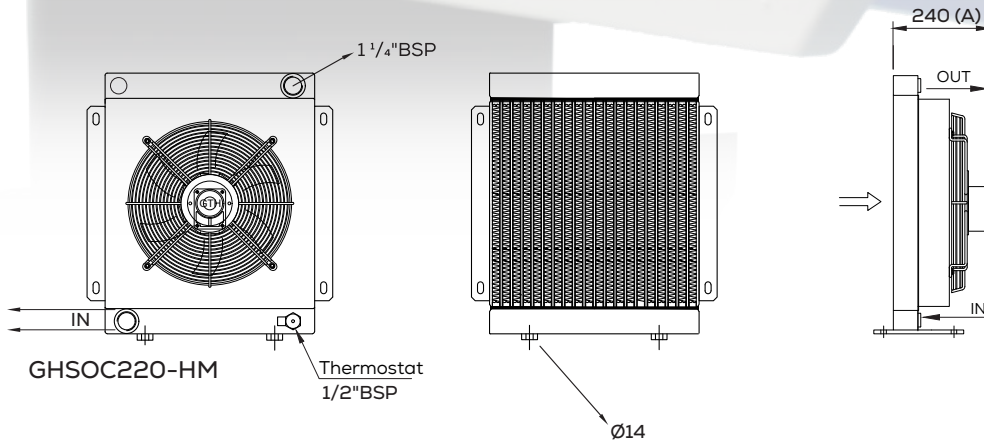
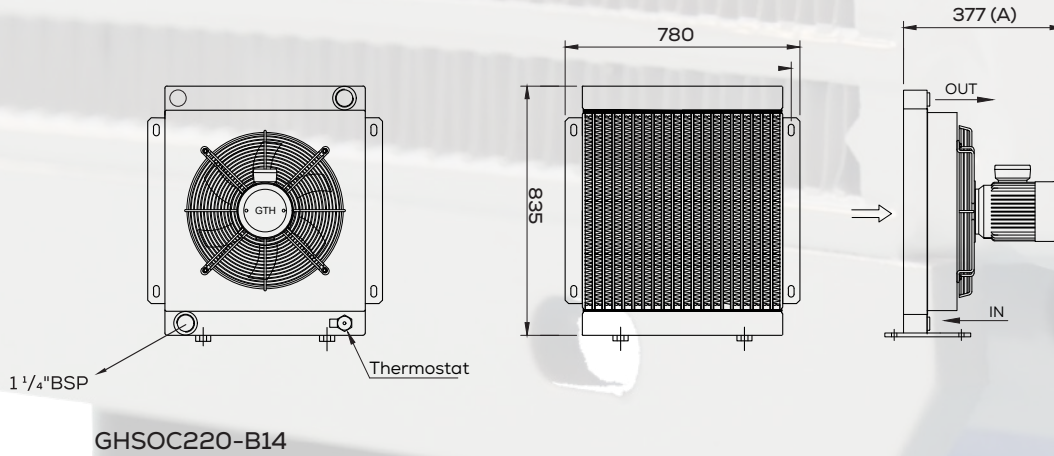
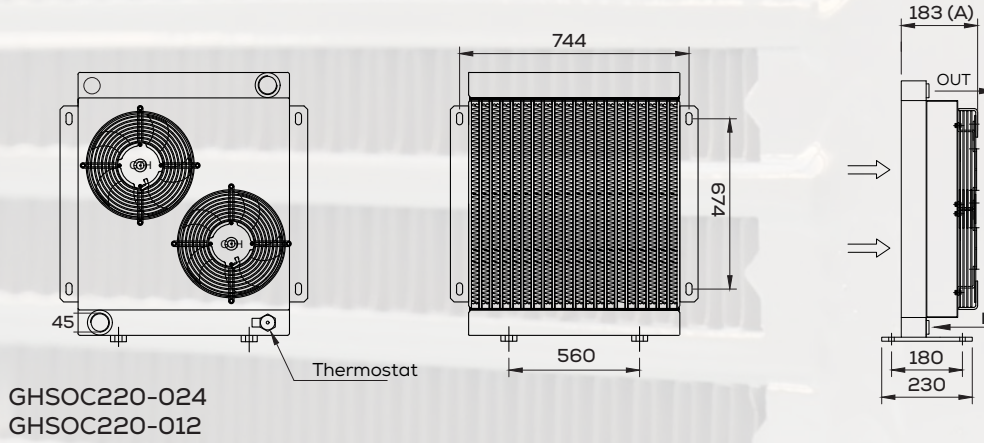
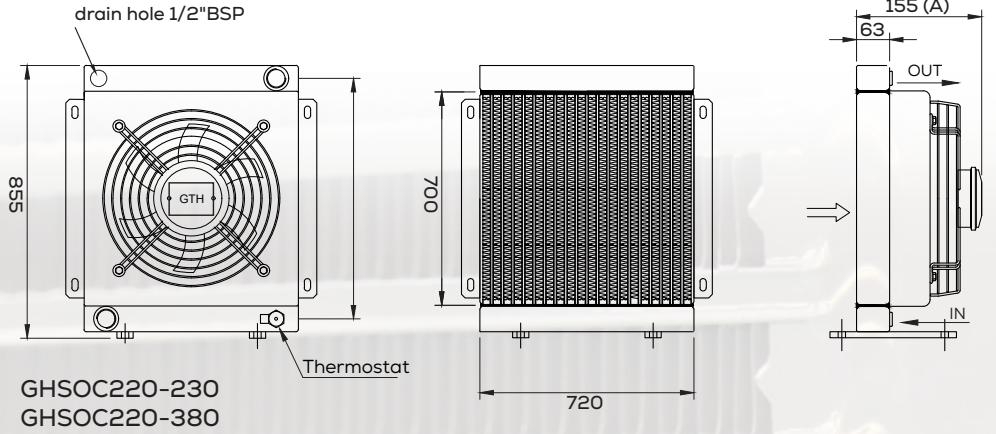

GHSOC220	Fan ø	Voltage V	Frequency Hz	Current A	kW(W)	rpm	m ³ /h	dB(A)	IP
024	304x2	24V	/	8.0A	0.18	2700	1200	60-70	68
012	304x2	12V	/	16.0A	0.18	2700	1200	60-70	68
230	300x2	230	50	0.65A	0.145	2500	2100	61	54
380	300x2	380	50	0.28A	0.135	2500	2300	62	54
230M	630	230	50	3.60A	0.8	1350	10050	75	54
380M	630	380	50	1.50A	0.8	1350	10900	75	54
B14	600	230-400 AC B14	50	3.60A	1.5	955	4900	52	55
HM	Please contact for the Hydraulic Motor variant								

Performance Diagram

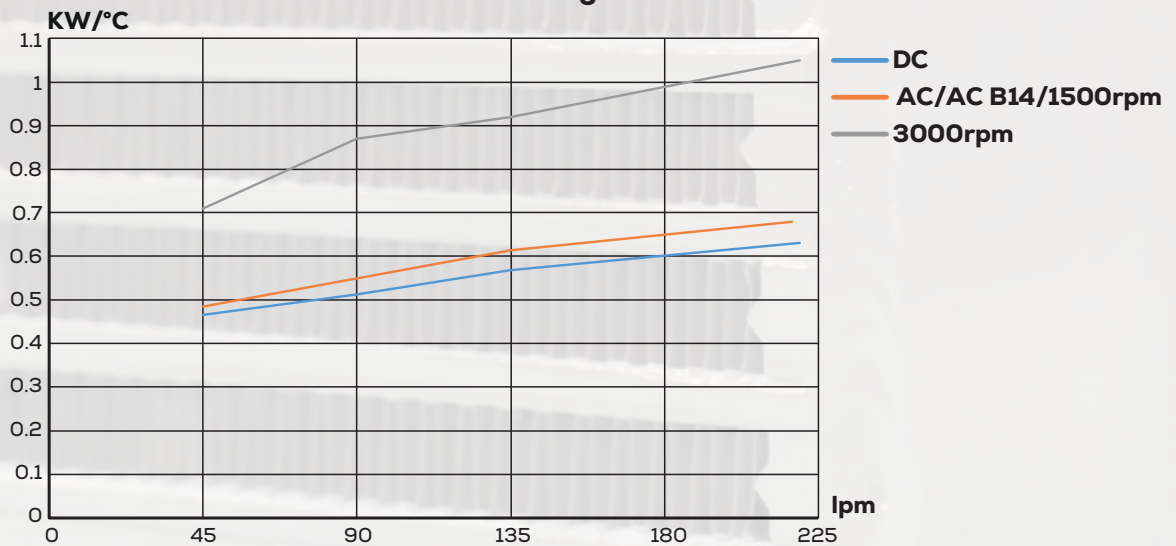

Pressure Drop

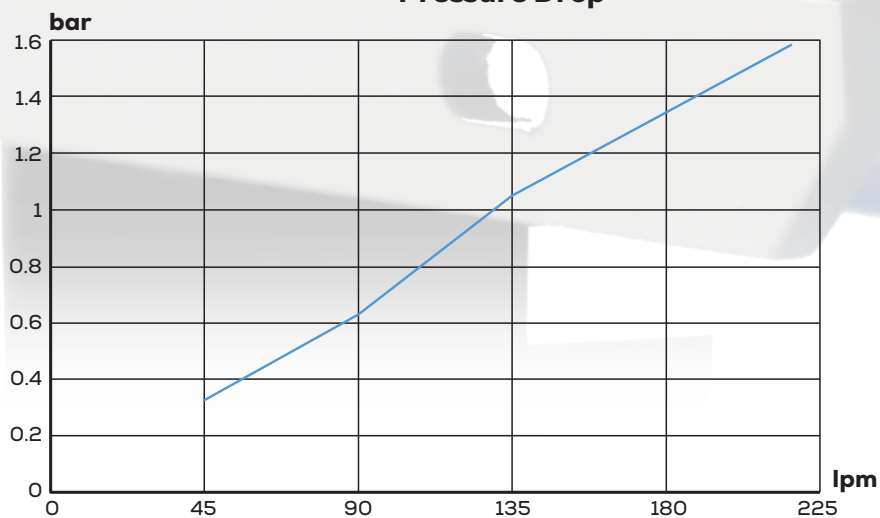

Correction Factor -F- (pressure drop)

cst	10	15	20	30	40	50	60	80	100	200	300
F	0,5	0,65	0,76	1	1,21	1,4	1,6	1,9	2,1	3,4	4,3

ADJUSTABLE THERMOSTAT

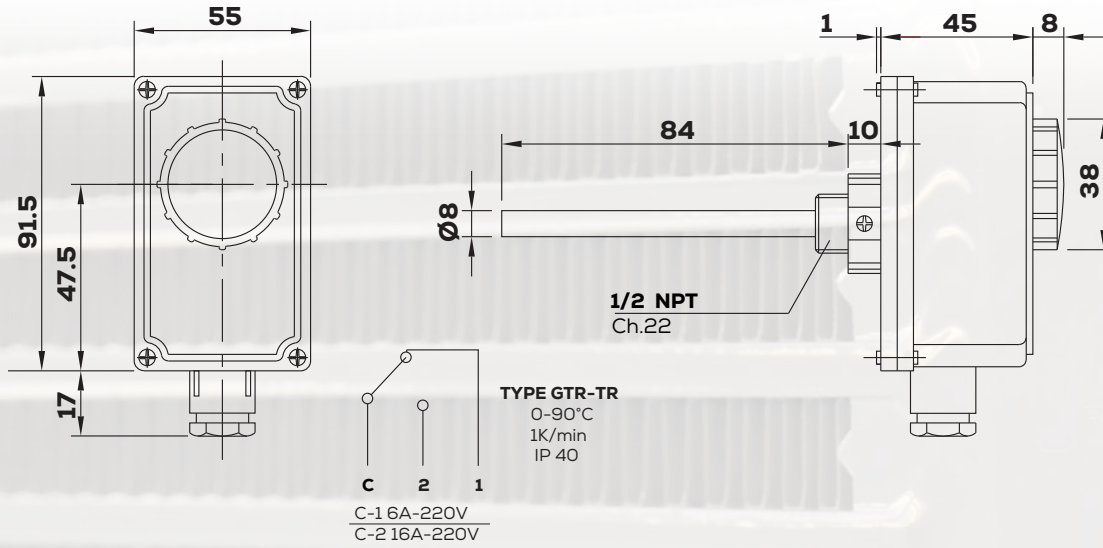

THERMOSTAT

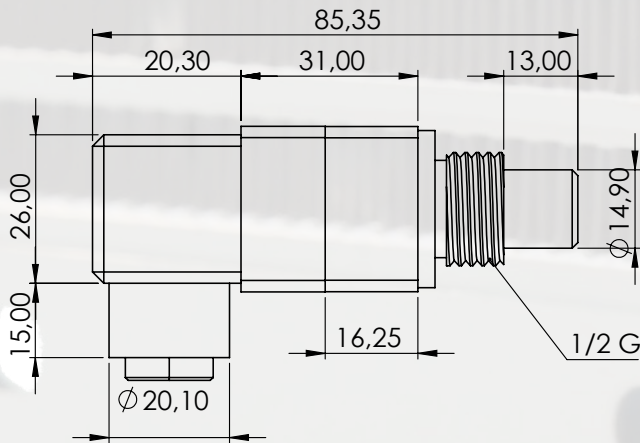

ELECTRICAL WIRING DIAGRAM

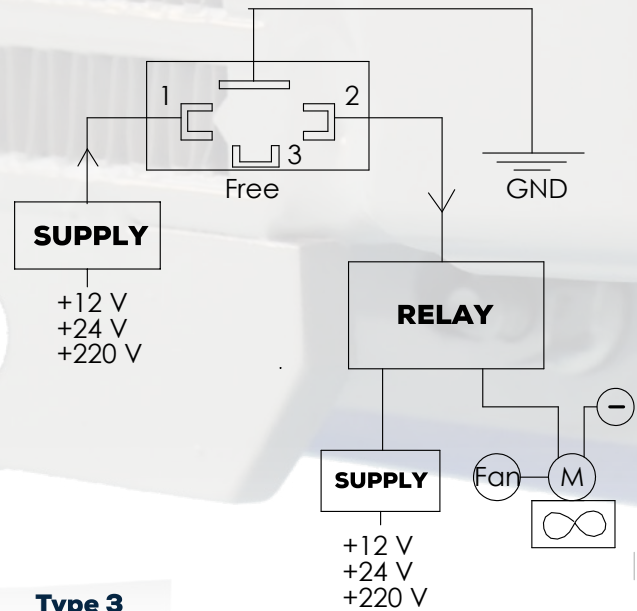

TECHNICAL DETAILS	Type 1	Type 2	Type 3
On Temperature	45 °C	55 °C	60 °C
Off Temperature	40 °C	50 °C	55 °C
Electrical Parameters	250 10A	250 10A	250 10A
Body Material	Aluminium probe	Aluminium probe	Aluminium probe
Connection Type	G1/2 thread	G1/2 thread	G1/2 thread

adjustable thermostat

technical description

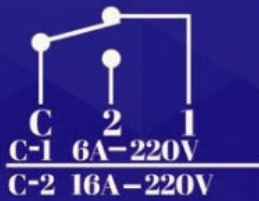

TYPE GTR-TR
 0-90°C
 1K/min
 1P 40
 CE



thermostat

heat range

- 40-45°C
- 50-55°C
- 55-60°C

GHS SERIES





HIDROMAS
YOUR GLOBAL TIPPING PARTNER

Global Worldwide



Uniform Quality



Product Liability and Safety



On Time Delivery



Effective Service Network

