

A31

398SAE007EN00

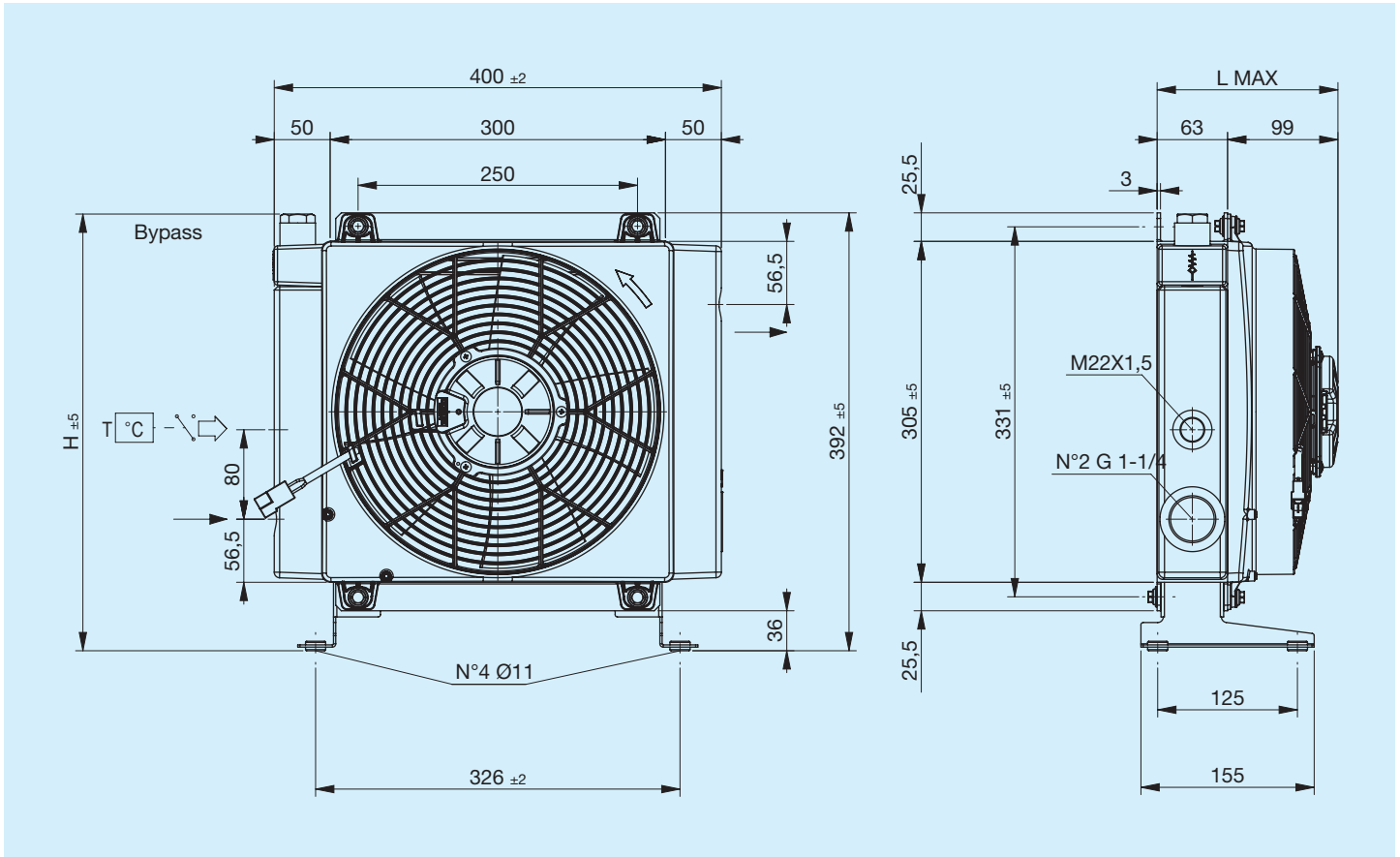

Before using the heat exchanger, carefully read the document entitled GENERAL INSTRUCTIONS FOR HEAT EXCHANGER USE.



Code	Description	Ø Fan	Air flow	Voltage	Amperage	L Max	H	Weight	Capacity
		mm	m ³ /h	V	A	mm	mm	Kg	l
FR633173105	A31 1EAX 12V bypass T15 V.T. 3 bar 60°C	280	2350	12	15	200	391	10,5	3,2
FR633173106	A31 1ESX 12V bypass T15 V.T. 3 bar 60°C	280	2350	12	15	200	391	10,5	3,2
FR633171005	A31 1EAX 12V bypass T15 VNR 4.5 bar	280	2350	12	15	200	375	10,5	3,2
FR633171006	A31 1ESX 12V bypass T15 VNR 4.5 bar	280	2350	12	15	200	375	10,5	3,2
FR633173115	A31 1EAX 24V bypass T15 V.T. 3 bar 60°C	280	2500	24	7	200	391	10,5	3,2
FR633173116	A31 1ESX 24V bypass T15 V.T. 3 bar 60°C	280	2500	24	7	200	391	10,5	3,2
FR633171015	A31 1EAX 24V bypass T15 VNR 4.5 bar	280	2500	24	7	200	375	10,5	3,2
FR633171016	A31 1ESX 24V bypass T15 VNR 4.5 bar	280	2500	24	7	200	375	10,5	3,2
FR633170003	A31 1EAP 12V	280	1420	12	9	155	394,5	9,7	3,2
FR633170004	A31 1ESP 12V	280	1420	12	9	155	394,5	9,7	3,2
FR633170005	A31 1EAX 12V	280	2350	12	15	200	394,5	10,5	3,2
FR633170006	A31 1ESX 12V	280	2350	12	15	200	394,5	10,5	3,2
FR633170013	A31 1EAP 24V	280	1550	24	5	155	394,5	9,7	3,2
FR633170014	A31 1ESP 24V	280	1550	24	5	155	394,5	9,7	3,2
FR633170015	A31 1EAX 24V	280	2500	24	7	200	394,5	10,5	3,2
FR633170016	A31 1ESX 24V	280	2500	24	7	200	394,5	10,5	3,2

Heat exchange capacity

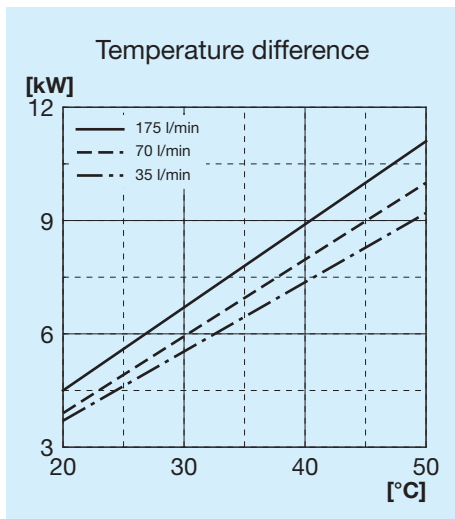

Radiator passage pressure drop

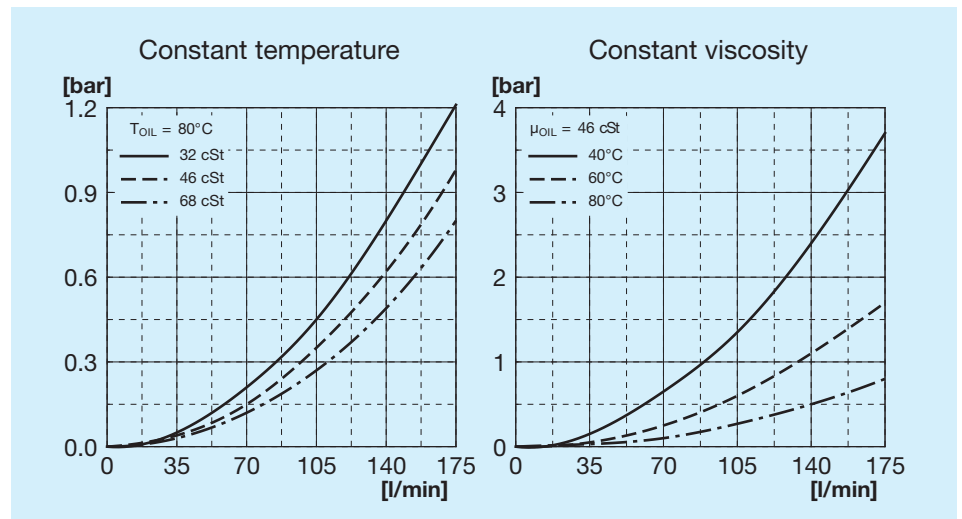

Bypass passage load loss

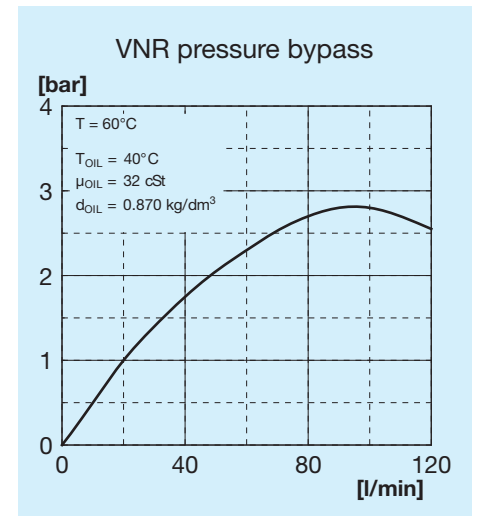
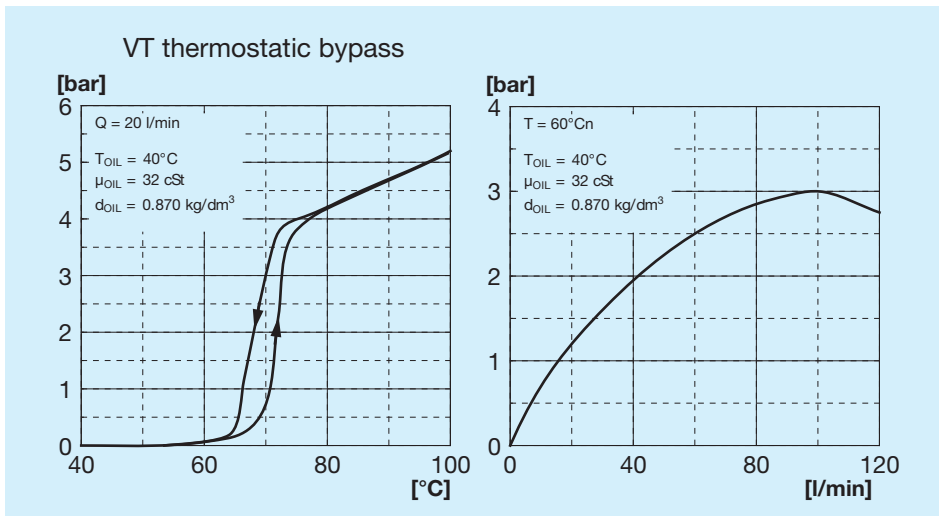

Bypass valves

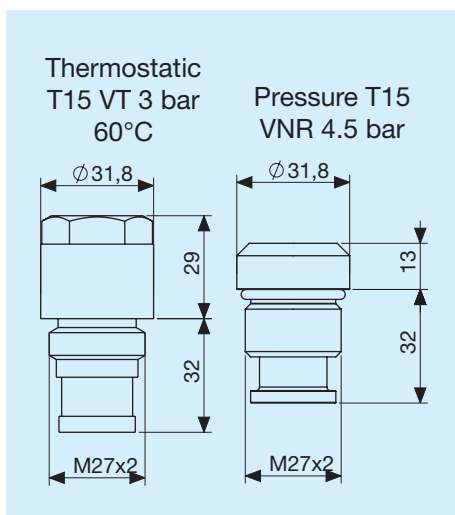

Legend

A31	Exchanger type
1E	1 Fan unit
AP	High power aspirating
SP	High power blower
AX	Extra high power aspirating
SX	Extra high power blower
12V	Fan unit voltage
24V	Fan unit voltage
T15 VT	Thermostatic bypass valve 3 bar 60°C
T15 VNR	Pressure bypass valve at 4.5 bar

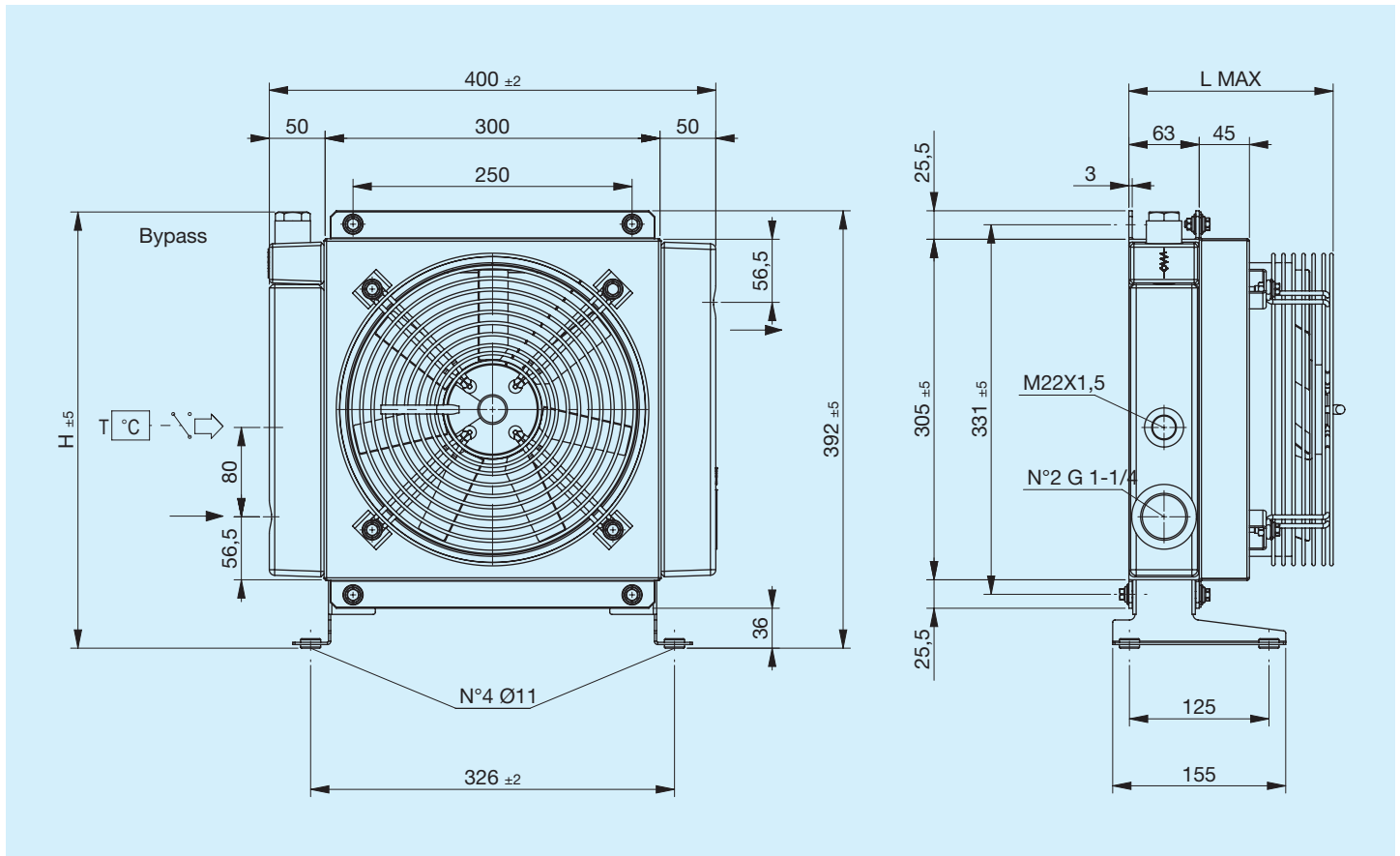

Code	Description	Ø Fan	Power	Frequency	Velocity	IP	L Max	H	Weight	Capacity
		mm	W	Hz	min ⁻¹		mm	mm		
FR633173131	A31 1EA 230V bypass T15 V.T. 3 bar 60°C	250	160	50 60	2500 2600	44	183	391	10	3,2
FR633173132	A31 1ES 230V bypass T15 V.T. 3 bar 60°C	250	160	50 60	2500 2600	44	183	391	10	3,2
FR633171031	A31 1EA 230V bypass T15 VNR 4.5 bar	250	160	50 60	2500 2600	44	183	375	10	3,2
FR633171032	A31 1ES 230V bypass T15 VNR 4.5 bar	250	160	50 60	2500 2600	44	183	375	10	3,2
FR633173121	A31 1EA 400V bypass T15 V.T. 3 bar 60°C	250	160	50 60	2450 2550	44	183	391	10	3,2
FR633173122	A31 1ES 400V bypass T15 V.T. 3 bar 60°C	250	160	50 60	2450 2550	44	183	391	10	3,2
FR633171021	A31 1EA 400V bypass T15 VNR 4.5 bar	250	160	50 60	2450 2550	44	183	375	10	3,2
FR633171022	A31 1ES 400V bypass T15 VNR 4.5 bar	250	160	50 60	2450 2550	44	183	375	10	3,2
FR633170031	A31 1EA 230V	250	160	50 60	2500 2600	44	183	394,5	10	3,2
FR633170032	A31 1ES 230V	250	160	50 60	2500 2600	44	183	394,5	10	3,2
FR633170021	A31 1EA 400V	250	160	50 60	2450 2550	44	183	394,5	10	3,2
FR633170022	A31 1ES 400V	250	160	50 60	2450 2550	44	183	394,5	10	3,2

Heat exchange capacity

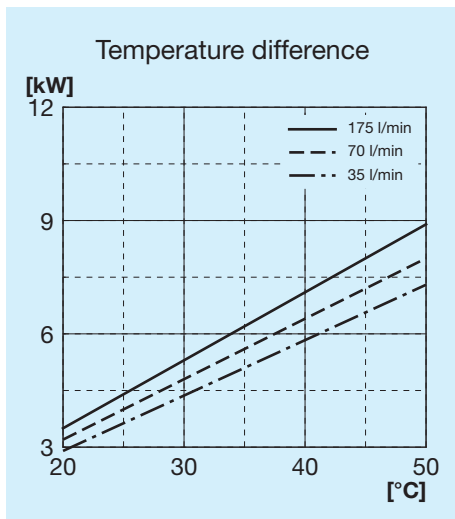

Radiator passage pressure drop

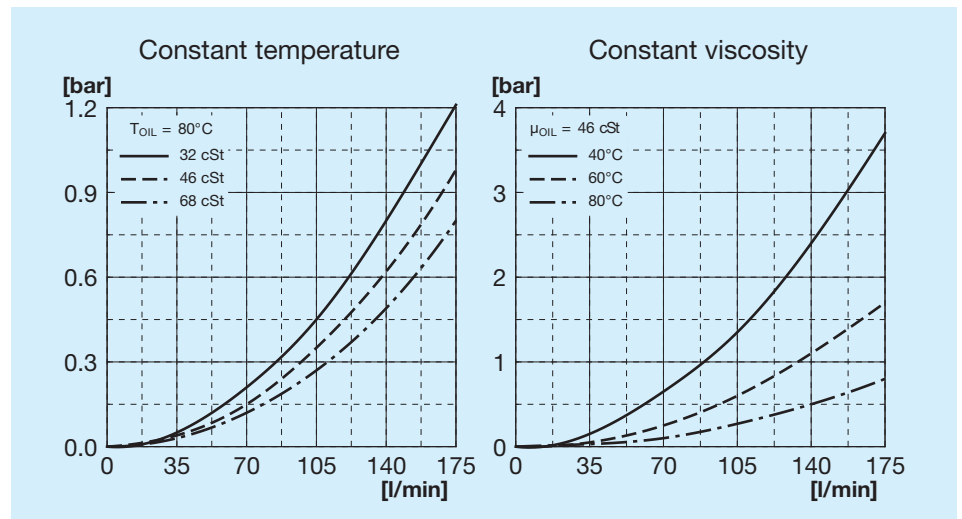

Bypass passage load loss

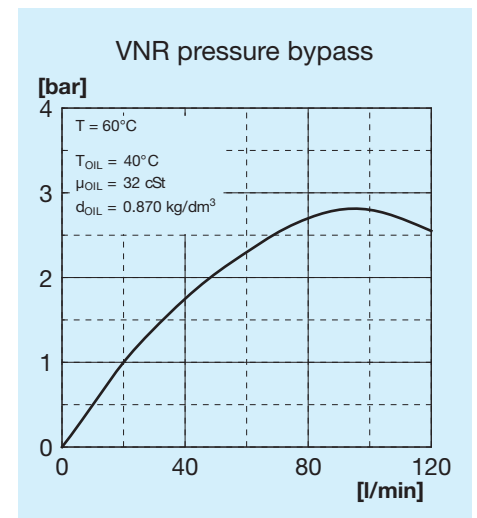
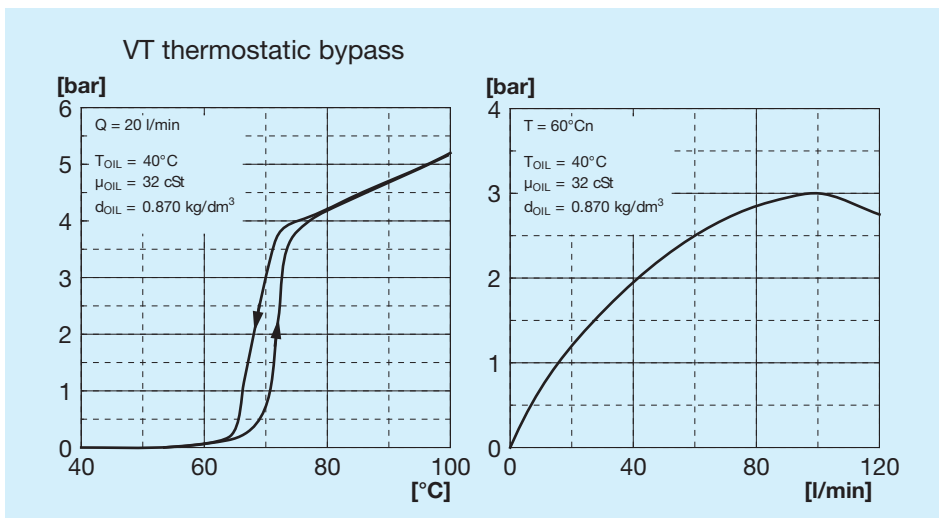

Bypass valves

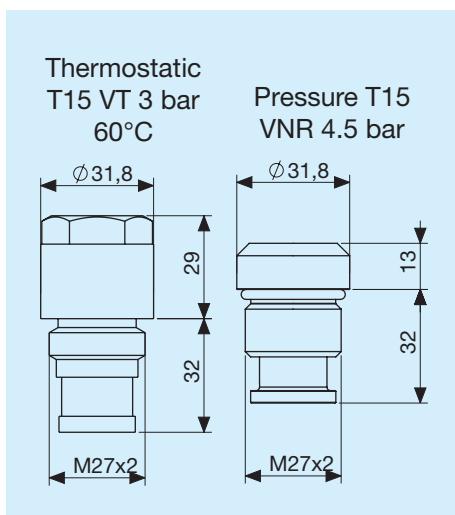

Legend

A31	Exchanger type
1E	1 Fan unit
AP	High power aspirating
SP	High power blower
AX	Extra high power aspirating
SX	Extra high power blower
12V	Fan unit voltage
24V	Fan unit voltage
T15 VT	Thermostatic bypass valve 3 bar 60°C
T15 VNR	Pressure bypass valve at 4.5 bar

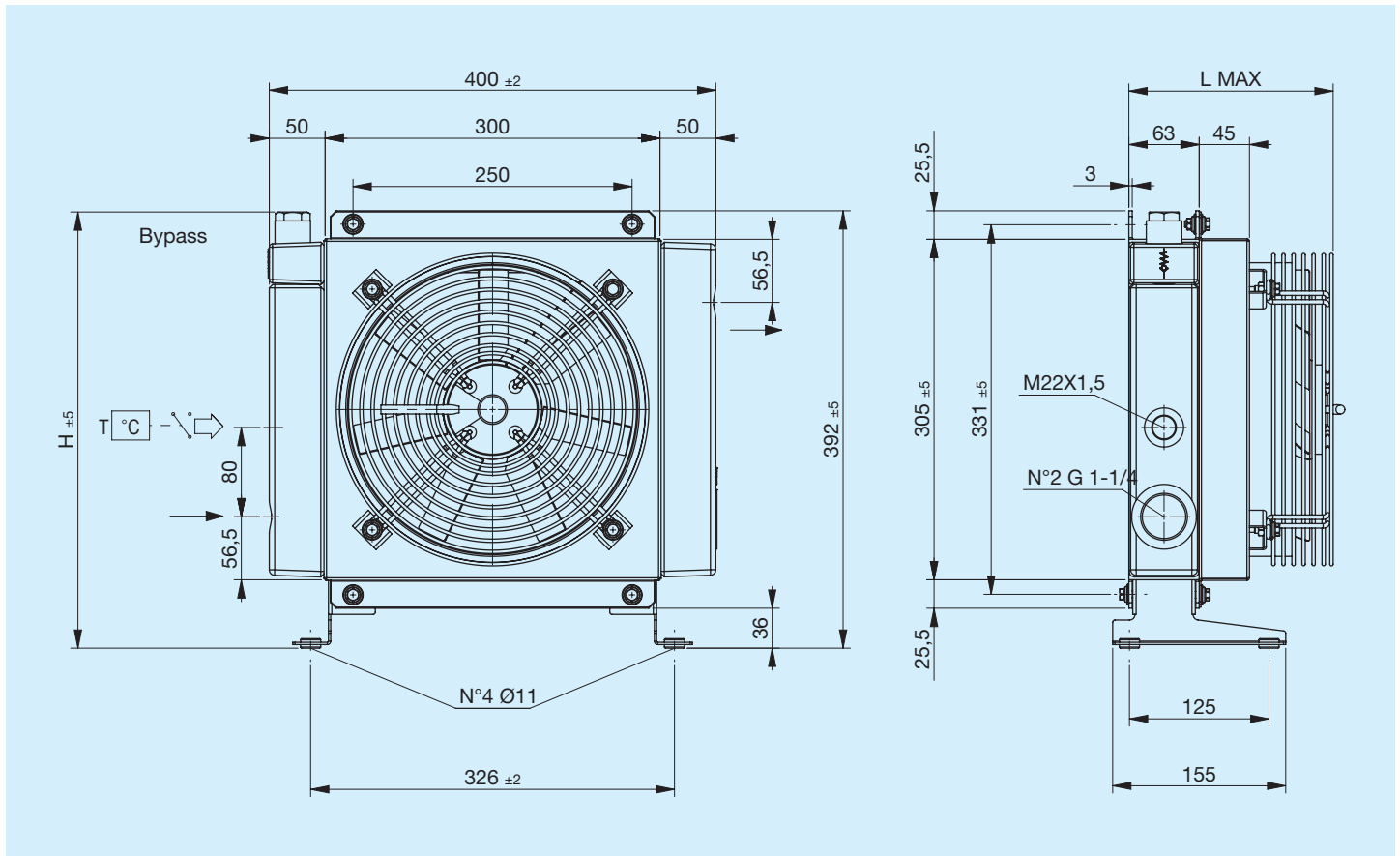

Code	Description	Ø Fan mm	Power W	Frequency Hz	Velocity min ⁻¹	IP Rating	L Max mm	H mm	Weight Kg	Capacity l
FR633173141	A31 1EA 220V-B14 bypass T15 V.T. 3 bar 60°C	290	370	50	2790	65	380	391	14,5	3,2
FR633173141	A31 1EA 220V-B14 bypass T15 V.T. 3 bar 60°C	290	370	50	2790	65	380	391	14,5	3,2
FR633171041	A31 1EA 220V-B14 bypass T15 VNR 4.5 bar	290	370	50	2790	65	380	375	14,5	3,2
FR633171041	A31 1EA 220V-B14 bypass T15 VNR 4.5 bar	290	370	50	2790	65	380	375	14,5	3,2
FR633173151	A31 1EA 380V-B14 bypass T15 V.T. 3 bar 60°C	290	370	50	2790	65	380	391	14,5	3,2
FR633173152	A31 1ES 380V-B14 bypass T15 V.T. 3 bar 60°C	290	370	50	2790	65	380	391	14,5	3,2
FR633171051	A31 1EA 380V-B14 bypass T15 VNR 4.5 bar	290	370	50	2790	65	380	375	14,5	3,2
FR633171052	A31 1ES 380V-B14 bypass T15 VNR 4.5 bar	290	370	50	2790	65	380	375	14,5	3,2
FR633170041	A31 1EA 220V-B14	290	370	50	2790	65	380	394,5	14,5	3,2
FR633170042	A31 1ES 220V-B14	290	370	50	2790	65	380	394,5	14,5	3,2
FR633170051	A31 1EA 380V-B14	290	370	50	2790	65	380	394,5	14,5	3,2
FR633170052	A31 1ES 380V-B14	290	370	50	2790	65	380	394,5	14,5	3,2

Heat exchange capacity

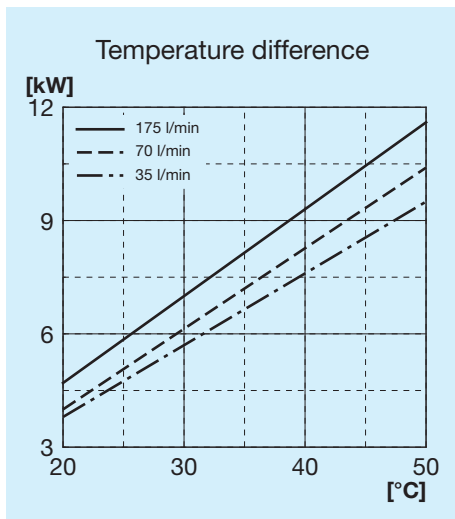

Radiator passage pressure drop

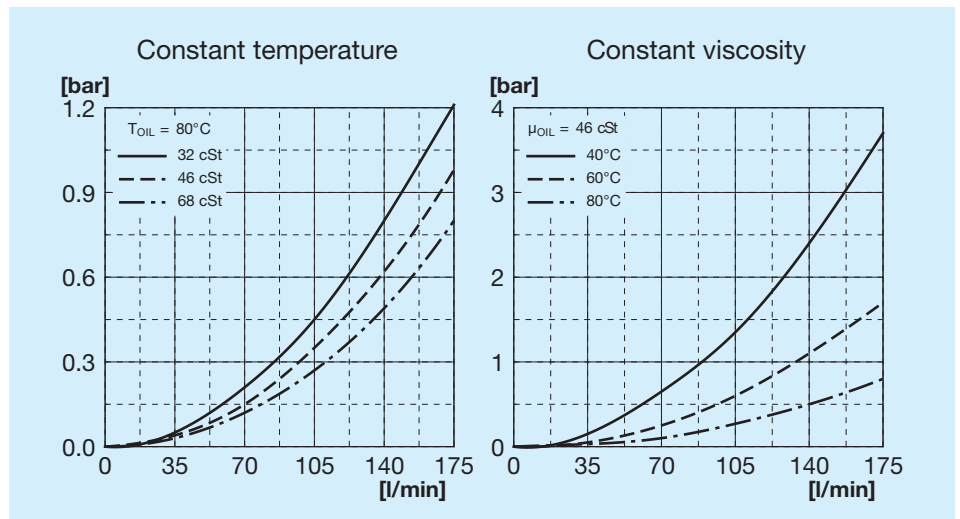

Bypass passage load loss

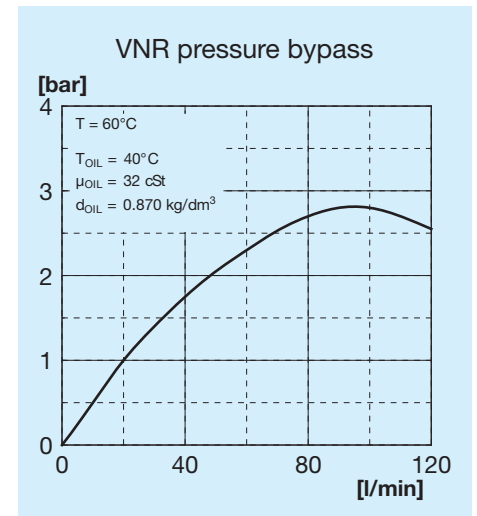
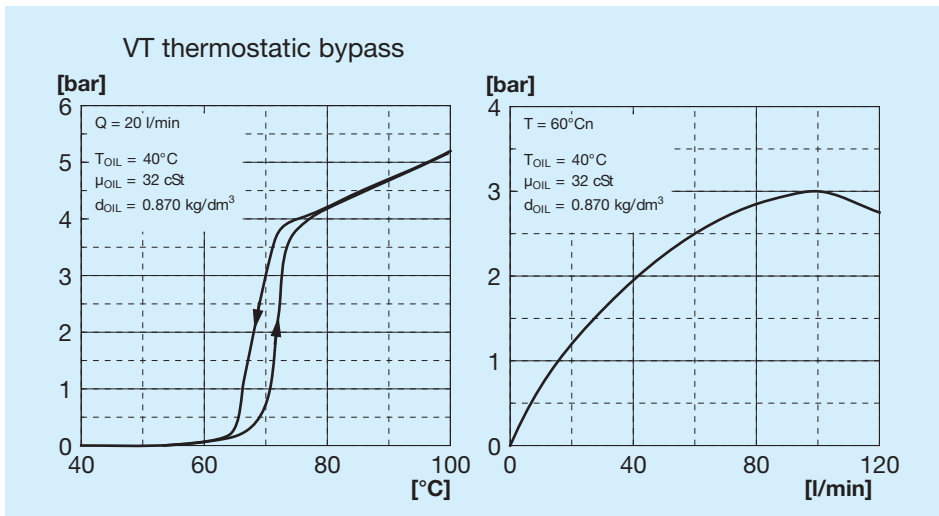

Bypass valves

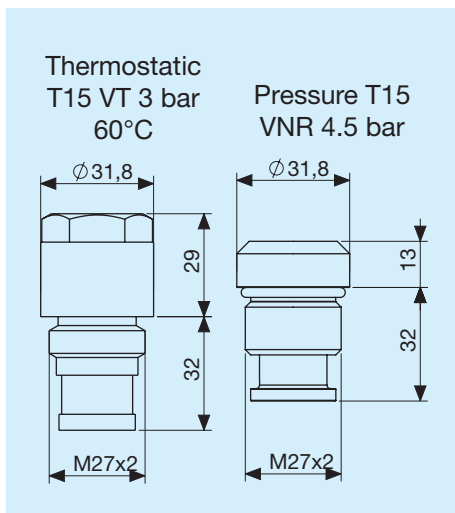

Legend

A31	Exchanger type
1E	1 Fan unit
AP	High power aspirating
SP	High power blower
AX	Extra high power aspirating
SX	Extra high power blower
12V	Fan unit voltage
24V	Fan unit voltage
T15 VT	Thermostatic bypass valve 3 bar 60°C
T15 VNR	Pressure bypass valve at 4.5 bar

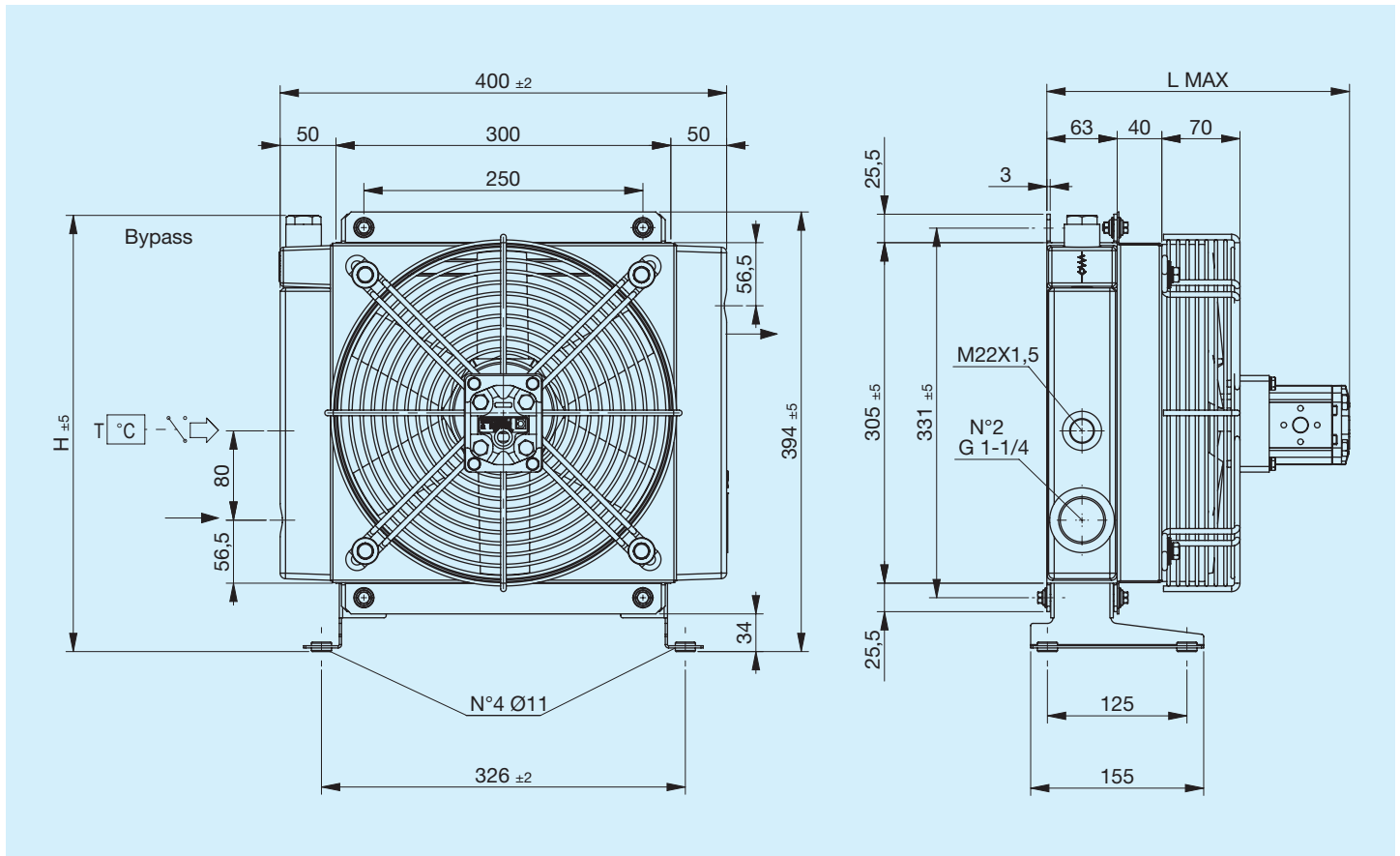

Code	Description	Ø Fan mm	Displacement motors cm ³ /h	L Max mm	H mm	Weight Kg	Capacity l
FR634173113	A31 IA MOT. IDR. GR1 bypass T15 V.T. 3 bar 60°C	290	6	275	391	14	3.2
FR634173114	A31 IS MOT. IDR. GR1 bypass T15 V.T. 3 bar 60°C	290	6	275	391	14	3.2
FR634171013	A31 IA MOT. IDR. GR1 bypass T15 VNR 4.5 bar	290	6	275	375	14	3.2
FR634171014	A31 IS MOT. IDR. GR1 bypass T15 VNR 4.5 bar	290	6	275	375	14	3.2
FR634170013	A31 IA MOT. IDR. GR1	290	6	275	394.5	14	3.2
FR634170014	A31 IS MOT. IDR. GR1	290	6	275	394.5	14	3.2

Heat exchange capacity

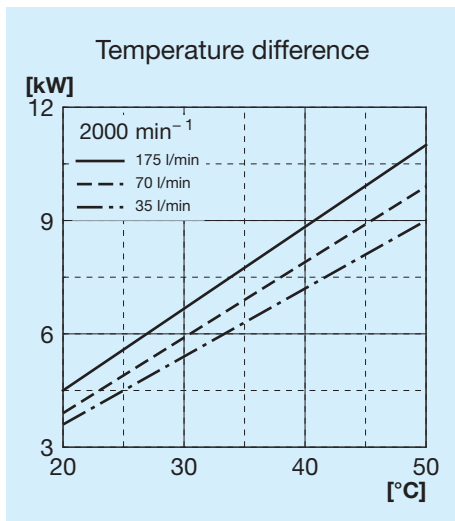

Radiator passage pressure drop

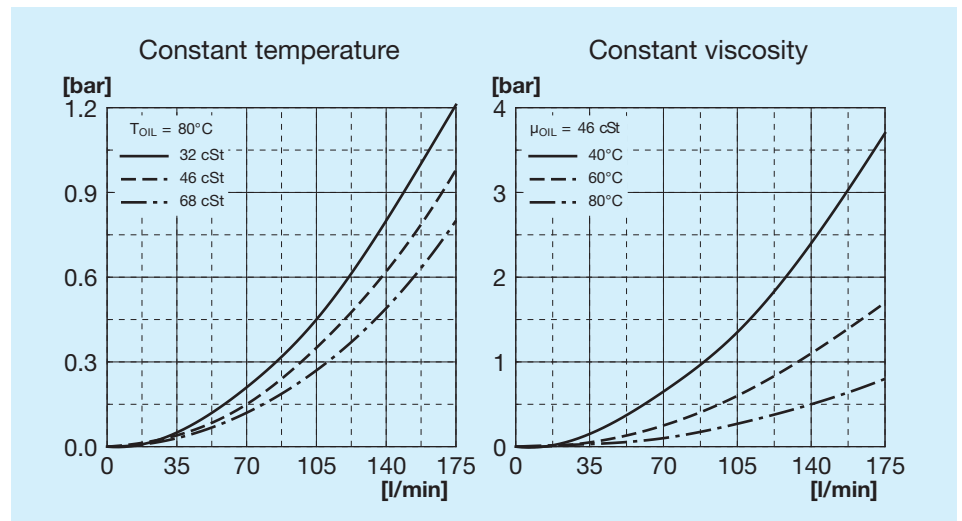

Bypass passage load loss

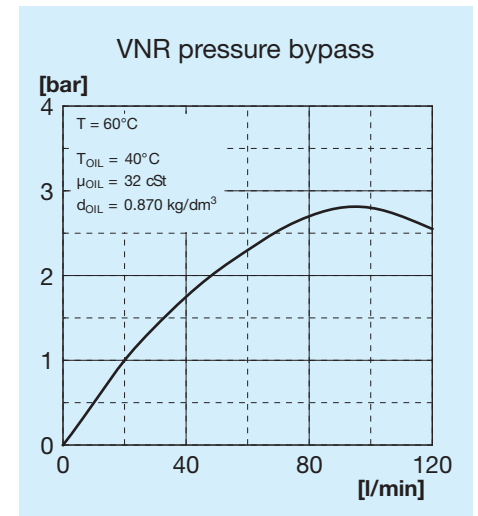
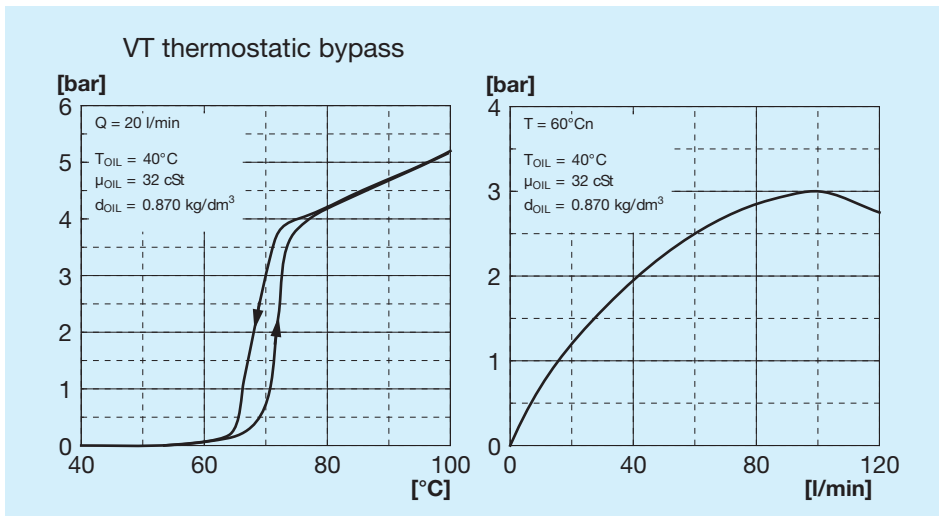

Bypass valves

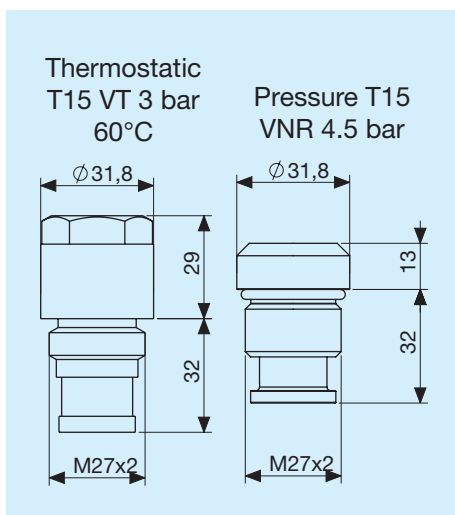

Legend

A31	Exchanger type
1E	1 Fan unit
AP	High power aspirating
SP	High power blower
AX	Extra high power aspirating
SX	Extra high power blower
12V	Fan unit voltage
24V	Fan unit voltage
T15 VT	Thermostatic bypass valve 3 bar 60°C
T15 VNR	Pressure bypass valve at 4.5 bar

Connector

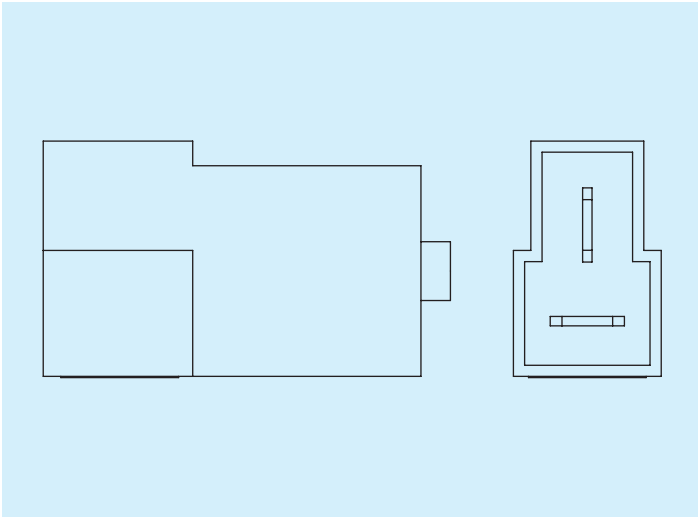

	Code
AMP connector	180908

Left supporting foot

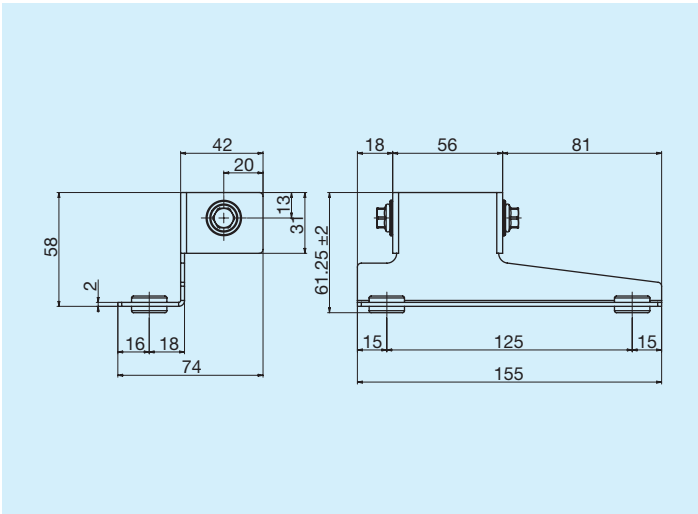

	Code
Left supporting foot	FR29000011

Right supporting foot

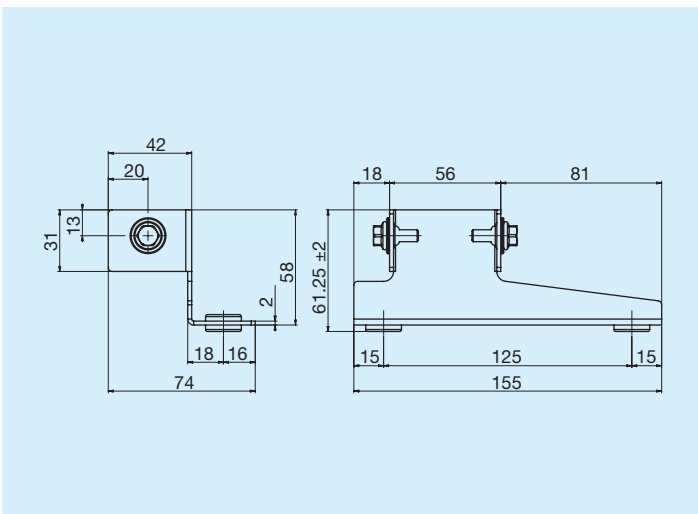

	Code
Right supporting foot	FR29000012

