



A TEREX BRAND

Parts Manual

Serial Number Range

Z-45/25

from SN Z4525D-940

Z-45/25J

DC

Part No. 1283270GT

Rev A2

November 2018

Technical Publications

Genie has endeavored to deliver the highest degree of accuracy possible. However, continuous improvement of our products is a Genie policy. Therefore, product specifications are subject to change without notice.

Readers are encouraged to notify Genie of errors and send in suggestions for improvement. All communications will be carefully considered for future printings of this and all other manuals.

Contact Us:

Internet: www.genielift.com
e-mail: awp.techpub@terex.com

Find a Manual for this Model

Go to <http://www.genielift.com>

Use the links to locate Operator's, Parts, Maintenance, and Service and Repair Manuals.

Copyright © 2011 by Terex Corporation

1283270GT Rev A April 2018
Fourth Edition, First Printing

Genie is a registered trademark of Terex South Dakota, Inc. in the USA and many other countries. "Z" is a trademark of Terex South Dakota, Inc.

 Printed on recycled paper

To August 31, 2016

Genie
A TEREX BRAND

Model:
Serial number: Z452516M-12345
Manufacture date: 1/2/16 **Model year:** 2016
Electrical schematic number:
Machine unladen weight:
Rated work load (including occupants):
Maximum number of platform occupants:
Maximum allowable side force:
Maximum allowable inclination of the chassis:

Z4525 16 M - 12345

1 2 3 4

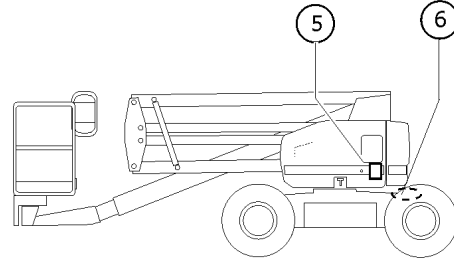

- 1 Model
- 2 Model year
- 3 Facility code

- 4 Sequence number
- 5 Serial label (located under cover)
- 6 Serial number (stamped on chassis)

From September 1, 2016

Genie
A TEREX BRAND

Model:
Serial number: Z4525M-12345
Year of manufacture: 2016
Electrical schematic number:
Machine unladen weight:
Rated work load (including occupants):
Maximum number of platform occupants:
Maximum allowable side force:
Maximum allowable inclination of the chassis:

Z4525 M - 12345

1 2 3

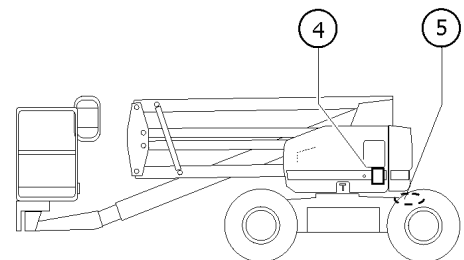

- 1 Model
- 2 Facility code
- 3 Sequence number

- 4 Serial label (located under cover)
- 5 Serial number (stamped on chassis)

Table of Contents

This manual is updated frequently. If you have a printed manual, you can keep it up to date by downloading new figures from the Genie website at www.genielift.com. For the most up-to-date parts information, visit the Parts Lookup System on the Genie website at www.genielift.com.

How to Read Your Serial Number.....	3
Parts Stocking List.....	7
How to Order Parts.....	8
Service Parts Fax Order Form.....	9

Electronic Version

Click on any page number to view the figure.

001 Parts Stocking List

001.1 Parts Stocking List.....	10
--------------------------------	----

100 Decals

101.1 Word Decals - DC Power.....	12
102.1 Symbol Decals - DC Power.....	16

200 Drive Chassis Components

201.1 Steer End.....	18
202.1 Non-steer End.....	20
203.1 Battery Packs.....	24
204.1 Battery Charger.....	26
205.1 Power Cables.....	28

300 Turntable Components

301.1 Turntable Rotator.....	30
302.1 Turntable Components - View 1.....	32
303.1 Turntable Components - View 2.....	34
304.1 Turntable Components - View 3.....	36
305.1 Ground Control Box - View 1.....	38
306.1 Ground Control Box - View 2.....	42
307.1 Turntable Covers - View 1.....	44
308.1 Turntable Covers - View 2.....	46
309.1 Wire Harness Diagram.....	48

400 Boom Components

401.1 Boom Pins and Bearings.....	50
402.1 Secondary Linkage.....	52
403.1 Upper Pivot.....	54
404.1 Primary and Extension Booms.....	56
405.1 Cable Track.....	58

406.1 Non-Jib Platform Leveling and Rotation (Z-45/25).....	60
407.1 Jib Platform Leveling (Z-45/25J).....	62
408.1 Jib Platform Rotation (Z-45/25J).....	64
409.1 Jib Detail (Z-45/25J).....	66

500 Platform Components

501.1 Platform Configuration.....	68
502.1 Platform Components.....	70
503.1 Platform Controls.....	72
504.1 Joystick Controller, Drive/Steer Functions.....	76
505.1 Rotational Controller.....	78

600 Pumps and Manifolds

601.1 Hydraulic Power Unit.....	80
602.1 Function Manifold.....	82
603.1 Jib Boom and Platform Rotate Manifolds.....	84

700 Hydraulic Hoses and Fittings

701.1 Drive and Steer Hoses.....	86
702.1 Turntable Components.....	88
703.1 Boom Components - Z-45/25.....	90
704.1 Boom Components - Z-45/25J.....	92

800 Accessories

801.1 Flashing Beacon.....	94
802.1 Platform Options.....	96
803.1 Half-height mesh and Swing Gate Options.....	98
804.1 Air Line to Platform.....	100
805.1 Platform Overload Option.....	102
806.1 Hostile Environment Package - View 1.....	104
807.1 Hostile Environment Package - View 2.....	106
808.1 Drive Lights.....	108
809.1 Traveling Fall Arrest Anchor System.....	110
810.1 Operators Protection Alarm (to January 2017).....	112
810.2 Lift Guard Contact Alarm (from January 2017).....	114

Indices

Part Number Index.....	116
Part Description Index.....	120

Cross References

Fittings Cross Reference.....	128
-------------------------------	-----

This Page Intentionally Left Blank

Please refer to section 001 for the Recommended Spare Parts List.

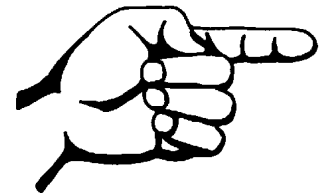

This page intentionally left blank.

How To Order Parts

How to Order Parts

Please be prepared with the following information when ordering replacement parts for your Terex or Genie product.

- Machine model number
- Machine serial number
- Part number
- Part description and quantity
- Purchase order number
- "Ship to" address
- Desired method of shipment
- Name and telephone number of the authorized distributor in your area.

Use the Service Parts Fax Order Form on the next page and fax your order to our Parts Department.

If you don't know the name of your authorized distributor, or if your area is not currently serviced by an authorized distributor, please call Terex or Genie Industries.

Machine Information

Model

Serial Number

Date of Purchase

Authorized Genie Distributor

Phone Number

North America

Telephone (425)881-1800
 Toll Free (800)536-1800 in US and Canada
 Fax (425)556-8659
 Toll Free fax (888)274-6192
 Email AWP.PartsSalesPO@terex.com
<http://genielift.com/en>

EMEAR (Europe, Middle East, Africa and Russia)

Telephone (31)(165)519 313
 Fax (31)(165)511 148
<http://genielift.co.uk>

Asia Pacific (Genie Singapore)

Telephone +65 6692 7777
 Fax +65 6261 8893
<http://genielift.com.sg/>

Australia

Telephone (61)(7)3456 4444
 Fax (61)(7)3456 4466
<http://genielift.com.au>

South America

Telephone (55)(11)4082 5600
 Fax (55)(11)4082 5630

001.1 Parts Stocking List

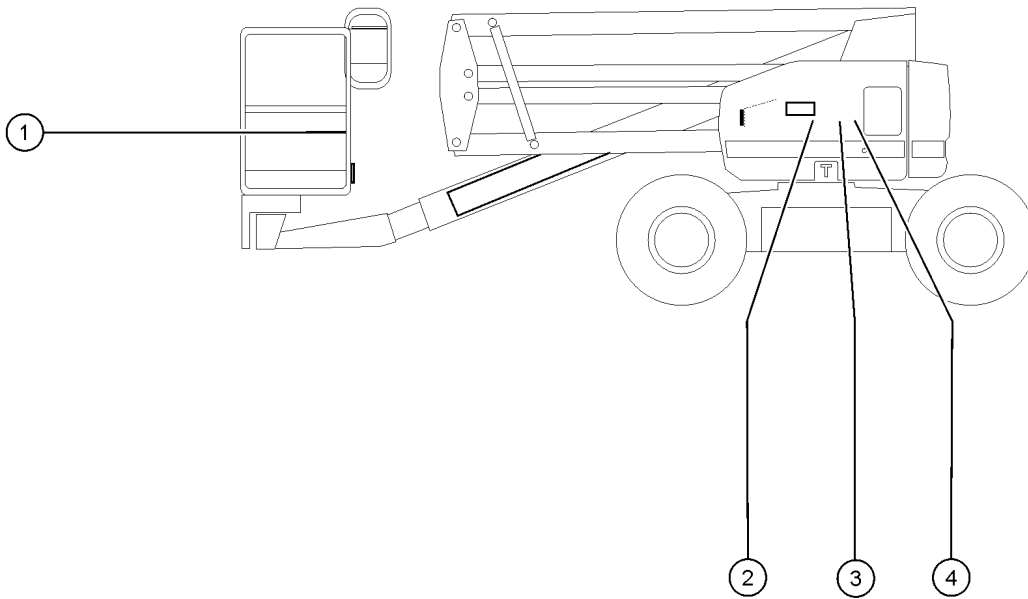

Item	Part No.	Description	Qty.
A		— GENERAL SERVICE PARTS —	
--	1257733GT	PAINT,WET,TRAFFIC BLACK (1 GL)** <i>1-gallon</i>	
--	1258567GT	PAINT, AEROSOL, TRAFFIC BLACK <i>12-ounce spray paint</i>	
--	1268GT	PAINT,AEROSOL,GENIE GRAY*** <i>12-ounce spray paint</i>	
--	1283776GT	SEAL MARKER,CROSS CHECK,BLUE,TUBE	
--	1484GT	PAINT,AEROSOL,BRIGHT BLUE*** <i>12-ounce spray paint</i>	
--	28750GT	O-RING KIT,FIELD SVC,ALL PROD* <i>O-ring kit, SAE</i>	
--	32150GT	PAINT,WET,GENIE BLUE (1 GL)** <i>1-gallon</i>	
--	32151GT	PAINT,WET,GENIE GRAY (1 GL)** <i>1-gallon</i>	
--	33994GT	PLUG AND CAP KIT-SERVICE,37 ** <i>Plug and cap kit, SAE</i>	
--	36555GT	CHOCK,CYLINDER (SERVICE TOOL)	
--	49612GT	O-RING KIT (ORFS FITTINGS) <i>O-ring kit, ORFS</i>	
--	49613GT	PLUG AND CAP KIT-SERVICE,ORFS* <i>Plug and cap kit, ORFS</i>	
--	66399GT	GREASE,DIELECTRIC 4 OZ**	
--	93500GT	PARKER DIGITAL PRESSURE GAUGE	
--			
1		— MANUALS —	
--	27581GT	MANUAL,AEM SAFETY	
--	31779GT	MANUAL,RESPON,A92.5 BOOM	

101.1 Word Decals - DC Power

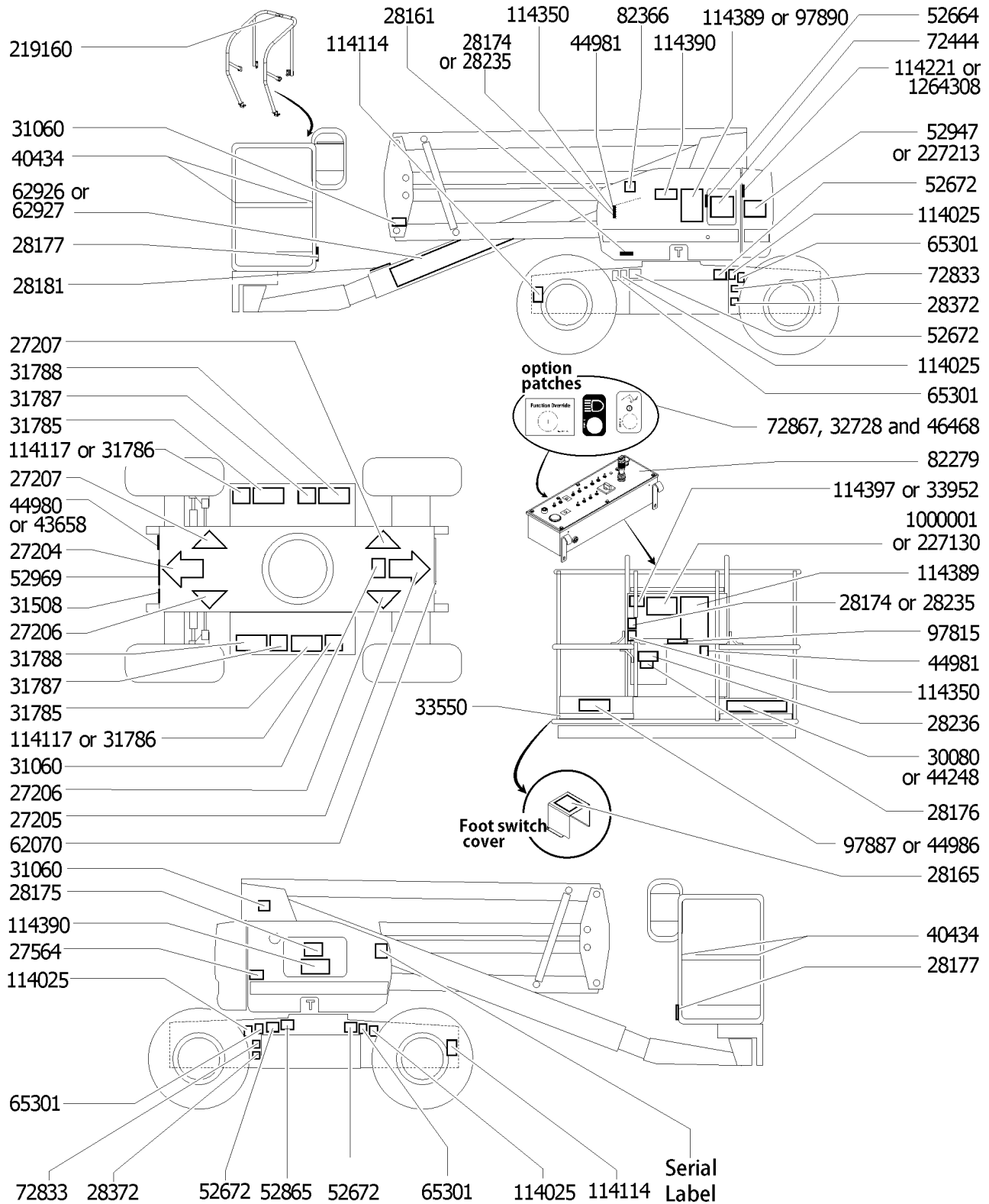

101.1 Word Decals - DC Power

Item	Part No.	Description	Qty.	Item	Part No.	Description	Qty.
--	822005GT	DECAL KIT,Z45 PLAT,WORD,ANSI <i>Platform Decal Kit, ANSI</i>		19	31508GT	DECAL,DANGER,ELECT HAZARD,PLUG.....	1
--	822006GT	DECAL KIT,Z45 COMP,WORD,ANSI <i>Complete Decal Kit, ANSI (from SN 33948 to 34010) (from SN A-34011) (from SN B-101) (from SN D-101)</i>		20	31785GT	DECAL,NOTICE,CHARGER INSTRUC...2	
--	822013GT	DECAL KIT,Z45 PLAT,WORD,AUS <i>Platform Decal Kit, AUS (from SN A-40560) (from SN B-1726) (from SN D-101)</i>		21	31786GT	DECAL,NOTICE,BATT CONNECTION...2 <i>to SN 33947</i>	
--	822014GT	DECAL KIT,Z45 COMP,WORD,AUS <i>Complete Decal Kit, AUS (from SN A-40560) (from SN B-1726) (from SN D-101)</i>		22	31787GT	DECAL,DANGER,TIP-OVER BATTERY.....	2
--	822038GT	DECAL KIT,Z45 PLAT,WORD,AUS <i>Platform Decal Kit, AUS (to 34010) (from SN A-34011 to A-40559) (from SN7B-101 to B-1725)</i>		23	31788GT	DECAL,DANGER,BATTERY SAFETY***.....	2
--	822039GT	DECAL KIT,Z45 COMP,WORD,AUS <i>Complete Decal Kit, AUS (from SN 33948 to 34010) (from SN A-34011 to A-40559) (from SN B-101 to B-1725)</i>		24	32728GT	DECAL,OPTION GENERATOR***.....1	
1	114020GT	DECAL KIT, Z45 DC & BI, WORDS <i>from SN 27000 to 33947; includes items 2-5, 8, 11, 14-17, 19, 20, 22, 23, 25, 27, 28, 30, 31, 45, 47 and 50</i>		25	33550GT	TAPE,WARNING,BLK/YEL, 50**** <i>(sold by the roll. 648" per roll) (Required to be install at base of platform toeboard for Australian market)</i>	
2	27204GT	DECAL,ARROW BLUE.....	1	26	33952GT	DECAL,DANGER,TILT ALARM.....1 <i>to SN 33947</i>	
3	27205GT	DECAL,ARROW YELLOW LRG 9".....	1	27	40434GT	DECAL,LANYARD ANCHORAGE POINT.....	8
4	27206GT	DECAL,TRIANGLE,BLUE.....	2	28	43658GT	DECAL,LABEL,PWR TO CHARGR 230V.....	1
5	27207GT	DECAL,TRIANGLE,YELLOW.....	2	29	44248GT	DECAL,NOTICE,MAX CAP 440 LBS <i>(for aircraft protection package)</i>	
6	27564GT	DECAL,DANGER,ELEC.HAZ.STAY CLR.....	2	30	44980GT	DECAL,LABEL,PWR TO CHARGR 115V.....	1
7	28161GT	DECAL,WARN,CRUSH HAZARD HAND.....	3	31	44981GT	DECAL,LABEL, AIR LINE 110 PSI.....2	
8	28165GT	DECAL,INSTRUCT,FOOTSWITCH OPER.....	1	32	44986GT	DECAL,INSTR,SIDE FRC/WIND,AUS.....1 <i>Australia models</i>	
9	28174GT	DECAL, POWER TO PLATFORM 230V**.....	2	33	46468GT	DECAL,FUNCTION OVERRIDE.....1 <i>(for aircraft protection package, from SN 37297)</i>	
10	28175GT	DECAL,WARNING-COMPART ACCESS.....	1	34	52664GT	DECAL,LABEL,CONTRLR STATUS LT.....	1
11	28176GT	DECAL,LABEL,MANUAL NOT HERE.....	1	35	52672GT	DECAL,DANGER,TIPOVER HAZARD***.....	4
12	28177GT	DECAL,WARN,CRUSH HAZARD PLAT.....	2	36	52865GT	DECAL,ANNUAL INSP***.....	1
13	28181GT	DECAL,WARN,FALL HAZARD.....	1	37	52947GT	DECAL,OPERATING INSTR,GROUND.....	1
14	28235GT	DECAL,POWER TO PLATFORM 115V...2		38	52969GT	DECAL,COSMETIC,GENIE BOOM,HORZ.....	1
15	28236GT	DECAL,WARN,IMPROPER OPERATION.....	1	39	62070GT	DECAL,COSMETIC,DC POWER.....1	
16	28372GT	DECAL,NOTICE,BATTERY CABLES....2		40	62926GT	DECAL,COSMETIC,GENIE Z-45/25J.....1 <i>Jib models</i>	
17	30080GT	DECAL,NOTICE,MAX LOAD 500 LBS....1		41	62927GT	DECAL,COSMETIC,GENIE Z-45/25.....1 <i>Non-Jib models</i>	
18	31060GT	DECAL,DANGER DO NOT ALTER SWTC.....	3	42	65301GT	DECAL,NOTICE,FOAM-FILLED TIRES.....	4
				43	72444GT	DECAL,GROUND CONTROL PANEL.....1	
				44	72833GT	DECAL,LABEL,OPEN,LATCH.....2	
				45	72867GT	DECAL,LABEL,LIGHTS***.....	1



101.1 Word Decals - DC Power (continued)

Item	Part No.	Description	Qty.
46	82279GT	DECAL,PLATFORM CONTROL PANEL.....	1
47	82366GT	DECAL,CHEVRON RANDO HD.....	1
48	97815GT	DECAL,LABEL,LOWER MIDRAIL.....	1
49	97887GT	DECAL,INSTR,MAX SIDE FRC,ANSI..... <i>ANSI models</i>	1
50	97890GT	DECAL,DANGER,GEN SAFETY RULES..... <i>to SN 33947</i>	2
51	114025GT	DECAL,LABEL,WHEEL LOAD Z4525DC.....	4
52	114114GT	DECAL,LABEL,TRANSPORT.....	2
53	114117GT	DECAL,BATT CONN DIAGRAM..... <i>from SN 33948</i>	1
54	114221GT	DECAL,LABEL,RELAYS,Z45DC,BE.....	1
55	114350GT	DECAL,AC INVERTER POWER,115V....	2
56	114389GT	DECAL,DANGER,GENERAL SAFETY.... <i>from SN 33948</i>	2
57	114390GT	DECAL,DANGER,ELECT HAZARD***.... <i>from SN 33948</i>	2
58	114397GT	DECAL,DANGER,TILT ALARM..... <i>from SN 33948</i>	1
59	219160GT	DECAL, INSTRUCTION, OPS..... <i>option</i>	1
60	227130GT	DECAL,OPER INST,Z45DC PLAT AUS..... <i>Australia models</i>	1
61	227213GT	DECAL,OPER INST,DC BOOM GND AU..... <i>Australia models</i>	1
62	1000001GT	DECAL, INSTR, OP INST,DC..... <i>ANSI models</i>	2
62	1264308GT	DECAL,LABEL,RELAYS,Z45DC,BE	

This Page Intentionally Left Blank

102.1 Symbol Decals - DC Power

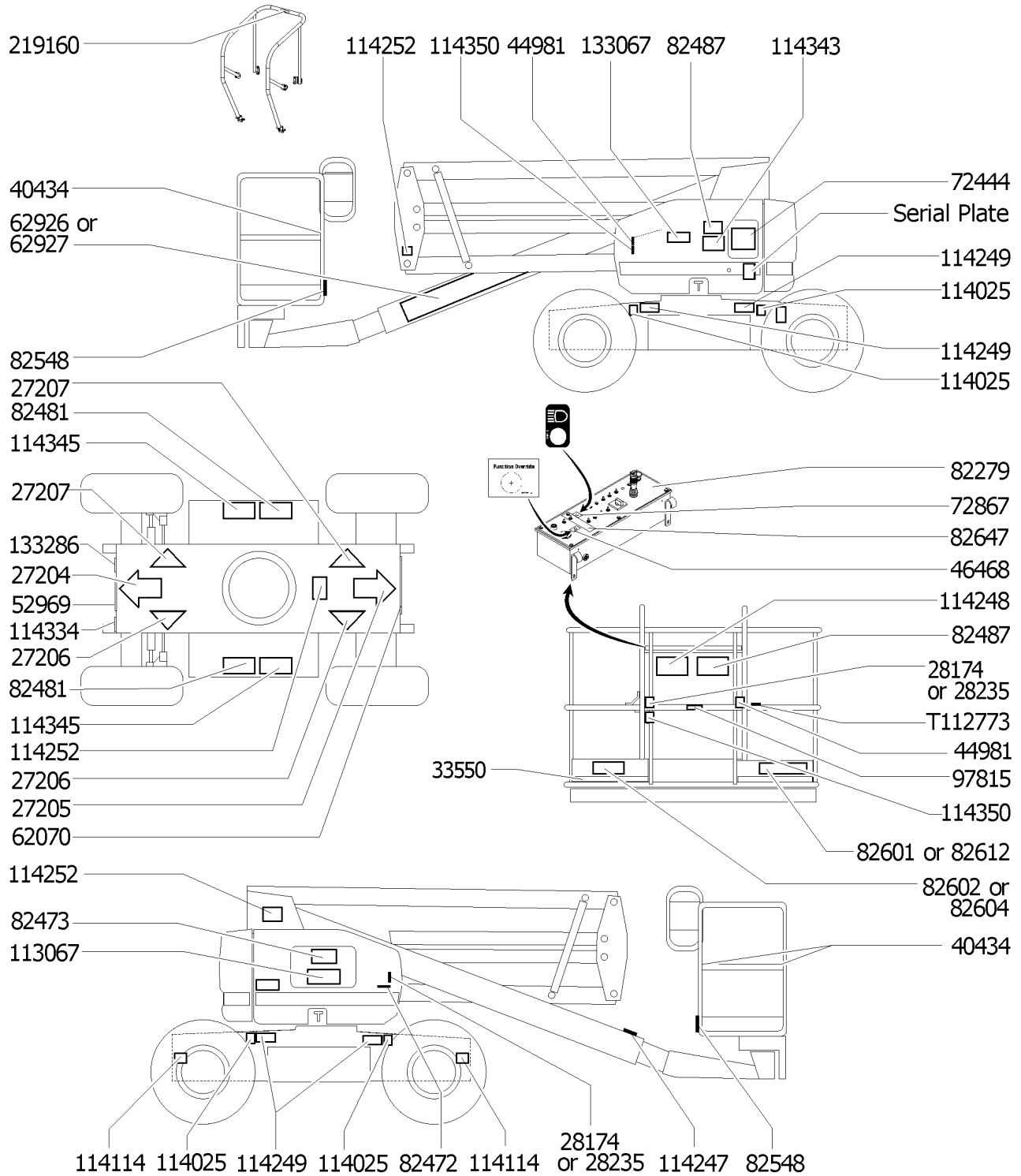

102.1 Symbol Decals - DC Power

Item	Part No.	Description	Qty.	Item	Part No.	Description	Qty.
A	823153GT	DECAL KIT,Z45 PLAT,SYM,ANSI <i>Platform Decal Kit, ANSI</i>		25	82602GT	DECAL,DANGER,MAX SIDE FRC,667N.....	1
B	823154GT	DECAL KIT,Z45DC COMP,SYM,ANSI <i>Complete Decal Kit, ANSI (from SN 33948 to 34010) (from SN A-34011) (from SN B-101) (from SN D-101)</i>		26	82604GT	DECAL,DANGER,SIDE FRC 400N.....	1
C	823161GT	DECAL KIT,Z45 PLAT,SYM,CE <i>Platform Decal Kit, CE</i>		27	82612GT	DECAL,DANGER,MAX CAP,200KG.....	1
D	823162GT	DECAL KIT,Z45DC COMP,SYM,CE <i>Complete Decal Kit, CE (from SN 33948 to 34010) (from SN A-34011) (from SN B-101) (from SN D-101)</i>		28	82647GT	DECAL,DRIVE ENABLE PATCH.....	1
1	82774GT	DECAL KIT,Z45 DC & BI,SYMB <i>(from SN 27000 to 33947) includes items 2-5, 8, 20, 22, 23, 25, 26, 33-41, and 43</i>		29	97815GT	DECAL,LABEL,LOWER MIDRAIL..... <i>CE models</i>	1
2	27204GT	DECAL,ARROW BLUE.....	1	30	133067GT	DECAL,DANGER,ELEC.HAZ.STAY CLR.....	2
3	27205GT	DECAL,ARROW YELLOW LRG 9".....	1	31	114025GT	DECAL,LABEL,WHEEL LOAD Z4525DC.....	4
4	27206GT	DECAL,TRIANGLE,BLUE.....	2	32	114114GT	DECAL,LABEL,TRANSPORT.....	2
5	27207GT	DECAL,TRIANGLE,YELLOW.....	2	33	114247GT	DECAL,LABEL,FALL HAZARD***.....	1
6	28174GT	DECAL, POWER TO PLATFORM 230V**.....	2	34	114248GT	DECAL,LABEL,TIPOVER,TILT AL SY.....	1
7	28235GT	DECAL,POWER TO PLATFORM 115V...2		35	114249GT	DECAL,LABEL,TIPOVER,TIRES,SYMB.4	
8	33550GT	TAPE,WARNING,BLK/YEL, 50*** <i>(sold by the roll. 648" per roll) (Required to be install at base of platform toeboard for CE market)</i>		36	114252GT	DECAL,LABEL,TIP OVER LMT SWTCH.....	3
9	40434GT	DECAL,LANYARD ANCHORAGE POINT.....	8	37	114334GT	DECAL,SYM-ELEC HAZARD,PLUG.....	1
10	44981GT	DECAL,LABEL, AIR LINE 110 PSI.....	2	38	114343GT	DECAL,LABEL,EMERGENCY DOWN....	1
11	46468GT	DECAL,FUNCTION OVERRIDE.....	1	39	114345GT	DECAL,LABEL,TIPOVER,BATTERIES....	2
12	52969GT	DECAL,COSMETIC,GENIE BOOM,HORZ.....	1	40	114350GT	DECAL,AC INVERTER POWER,115V...2	
13	62070GT	DECAL,COSMETIC,DC POWER.....	1	41	133067GT	DECAL,DANGER,ELEC.HAZ.STAY CLR	
14	62926GT	DECAL,COSMETIC,GENIE Z-45/25J <i>jib</i>		42	133286GT	DECAL, POWER TO CHARGER, UNIV.....	1
15	62927GT	DECAL,COSMETIC,GENIE Z-45/25..... <i>non-jib</i>	1	43	219160GT	DECAL, INSTRUCTION, OPS..... <i>option</i>	1
16	72444GT	DECAL,GROUND CONTROL PANEL.....	1	44	T112773GT	TAPE, PROTECTIVE MASK.....	2
17	72867GT	DECAL,LABEL,LIGHTS***.....	1				
18	82279GT	DECAL,PLATFORM CONTROL PANEL.....	1				
19	82472GT	DECAL,WARNING,CRUSHING HAZARD.....	1				
20	82473GT	DECAL,SYMBOL-COMP ACCESS.....	1				
21	82481GT	DECAL,SYMBOL-BATTERY SAFETY....	2				
22	82487GT	DECAL, SYMBOL - READ THE MANUAL.....	1				
23	82548GT	DECAL,WARN,CRUSH HAZARD PLAT.....	2				
24	82601GT	DECAL,LABEL,MAX CAPACITY***.....	1				



201.1 Steer End

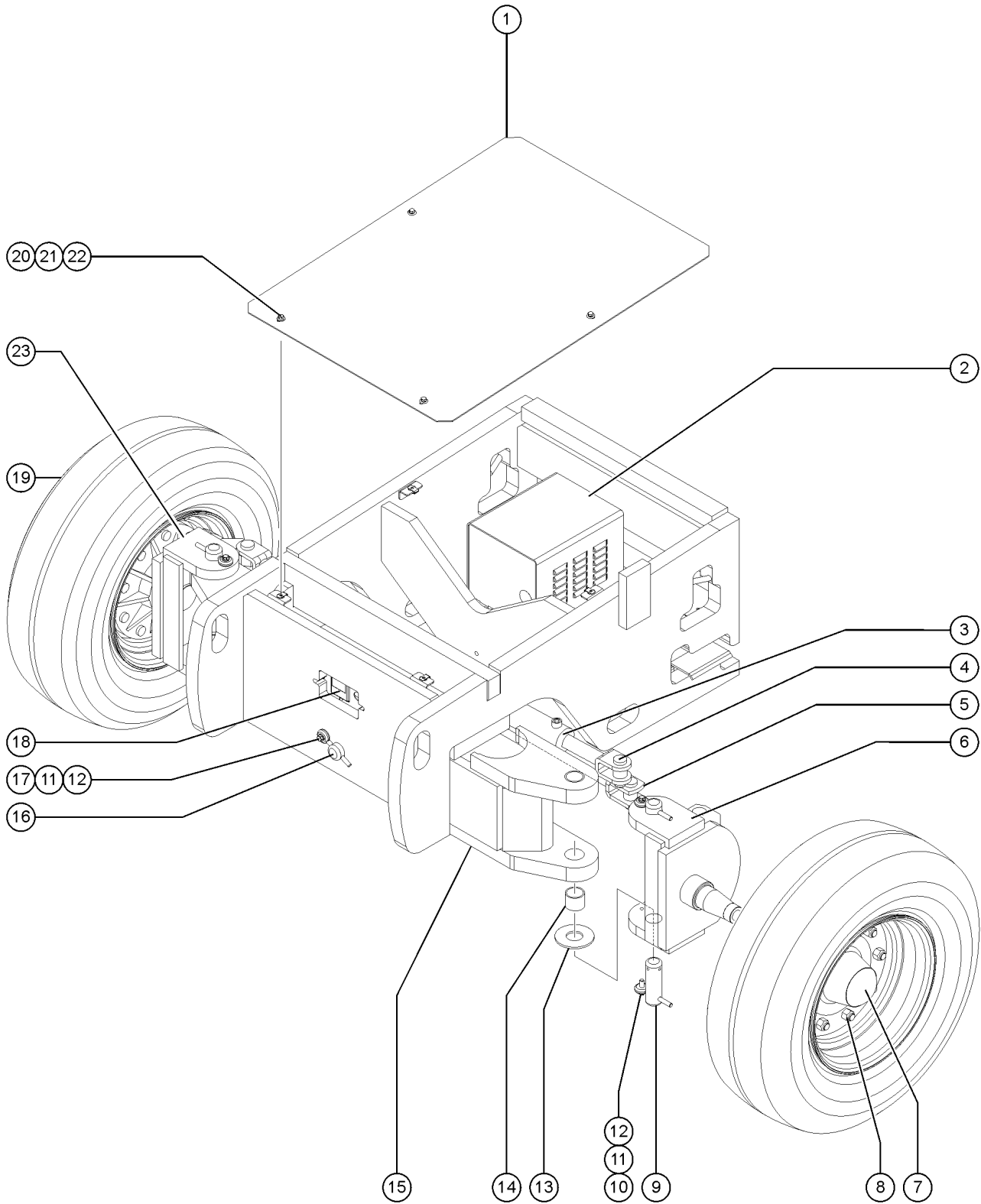

201.1 Steer End

Item	Part No.	Description	Qty.	Item	Part No.	Description	Qty.
--	54436GT	GROUND STRAP,18"LG.....1 <i>(models with non-marking tires and/or models with EE rating)</i>	1	19A	1267779GT	TIRE/WH ASSY,9 LG,FOAM,S FRONT...2 <i>(steer end)</i>	2
--	1267781GT	TIRE/WH ASSY,9 LG,NM,FOAM,S FR <i>(steer end)</i>	2	19B	1267781GT	TIRE/WH ASSY,9 LG,NM,FOAM,S FR...2 <i>(steer end)</i>	2
--	1267782GT	TIRE/WH ASSY,9LG,NM,FOAM,NS RE <i>(non-steerer end)</i>	2	19C	1267784GT	TIRE/WH ASSY,9 LG,REPNEU,S.....2 <i>(steer end)</i>	2
1		Ref., COVER, DRIVE, DRIVE LIGHT OPT. <i>models with drive lights (refer to 909.1)</i>		19D	1267786GT	TIRE/WH ASSY,9 LG,NM,REPNEU,S.....2 <i>(steer end)</i>	2
1	77434GT	COVER W/DECALS,STEER,NON OSC.....1	1	20	6888GT	SCREW,HHC,1/4-20 X 1	
2		Ref. Battery Charger <i>refer to 204.1</i>		21	6356GT	WASHER,LOCK, .25	
3	88337GT	CYLINDER,STEER.....2	2	22	56912GT	SPRING CLIP,1/4-20,.025-.15X.54,ZAG	
--	88338GT	SEAL KIT, 88337		23	52734-SGT	YOKE ASSY.LH'2WD'Z45IC.....1	1
4	19440GT	PIN,CLEVIS,1 X 2.5 LG.....4	4	--	25817GT	BEARING,1.00IDX1.25ODX1.00L.....2	2
--	5361GT	PIN,COTTER,.125 X 1.5					
5	229798GT	TIE ROD WELDMENT, NARROW.....1	1				
6	52733-SGT	YOKE ASSY.LH'2WD'Z45IC.....1	1				
--	25817GT	BEARING,1.00IDX1.25ODX1.00L.....2	2				
7	54840GT	HUB ASSEMBLY,9 BOLT***.....2	2				
--	45112GT	WASHER,SPINDLE					
--	45113GT	NUT,SPINDLE,1-14					
--	45114GT	PIN,COTTER,.219 X 1.75					
--	54959GT	CAP,DUST (54840 HUB ASSY)					
--	54960GT	SEAL-GREASE,9-BOLT HUB 54840					
--	54961GT	BEARING,INNER,9 BOLT HUB***					
--	54962GT	BEARING,OUTER,9 BOLT HUB***					
8	21166GT	LUG BOLT,5/8-18,WHEEL HUB***					
--	54627GT	NUT,LUG,5/8-18 X 90 DEGREE,Z45					
9	88752GT	PIN,1.50DIAX4.25LG,GR/H.....4	4				
--	825796GT	SNAP RING,EXTERNAL,1.50,ZAG					
10	6019GT	SCREW,HHC,3/8-16 X 1.25 GRD 5					
11	6021GT	WASHER,LOCK, .375					
12	825019GT	ROD END,.375X3.69,ZAG					
13	45074GT	WASHER,THRUST,1.5 X 3.5 X .187.....2	2				
14	45071GT	BEARING,1.5IDX1.75ODX1.5L					
15	52735GT	FRONT AXLE ASSY,NRRW,Z45/25.....1 <i>includes item 14; to SN 31771</i>	1				
--	119981GT	AXLE ASSY,FRONT,NARROW Z45/Z51 <i>includes item 14; from SN 31772</i>					
--	34245GT	BEARING,1.25IDX1.50X1.25L					
16	54542GT	PIN,1.50DIAX20.00LG,CHAMFER.....2	2				
--	30255GT	WASHER,SHIM,1.27 X 2.13 X .062					
17	6175GT	SCREW,HHC,3/8-16 X 1					
18	46337GT	AMMETER, 39243/47906/66412.....1	1				

202.1 Non-steer End

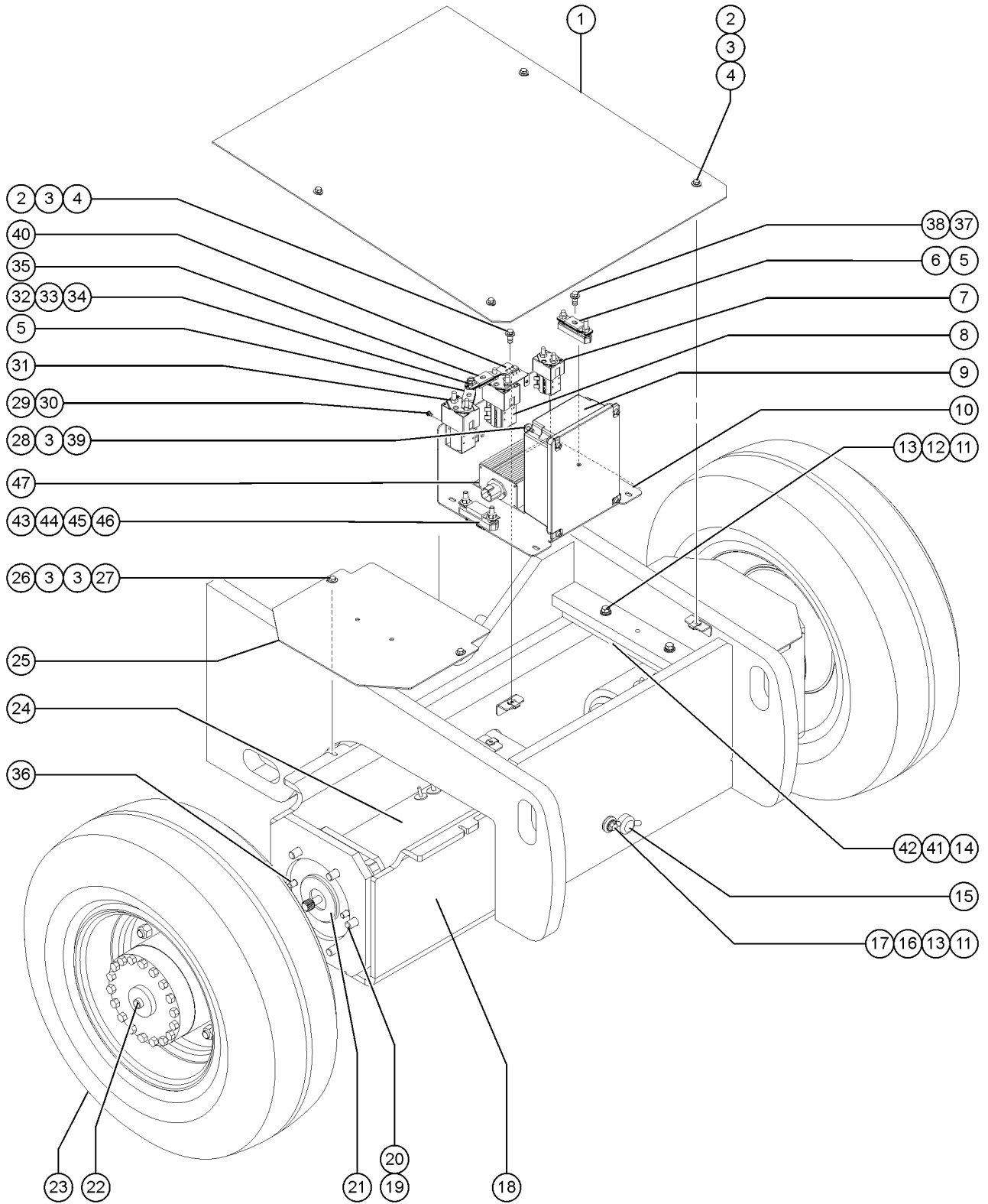

202.1 Non-steer End

Item	Part No.	Description	Qty.	Item	Part No.	Description	Qty.
1	52707-SGT	COVR W/DECALS, NON-STEER Z45/25.....	1	--	233807GT	BRAKE REPLACEMENT KIT.....1 <i>for 101966 brake</i>	
2	6090GT	SCREW, HHC, 1/4-20 X .75		--	65618GT	SEAL KIT, BRAKE*** <i>for 101966 brake</i>	
3	6638GT	WASHER, FLAT, USS, 1/4"Y		--	94879GT	LINING KIT*** <i>for 101966 brake</i>	
4	56912GT	SPRING CLIP, 1/4-20, .025-.15X.54, ZAG		--	94880GT	BEARING KIT <i>for 101966 brake</i>	
5	18576GT	FUSE, 200 AMP.....	2	22A	106148GT	WHEEL DRIVE, 4HB, 48:1***2 <i>(verify component before ordering) (Do Not use with 218570)</i>	
6	66717GT	FUSE BLOCK, ANN & ANL FUSE.....	1	--	106117GT	O-RING, 2-010, VITON <i>for 106148 (Mating O-ring for Brake Port)(Extremely small)</i>	
7	74268GT	CONTACTOR, AUX PUMP 24V, 80A***.....	1	--	106120GT	WHEEL STUD, 4HP, 5/8-18*** <i>for 106148</i>	
--	22262GT	CONTACT, MOVING, 19549RELAY*		--	106121GT	ROD, DISCONNECT 4HP/4HB*** <i>for 106148</i>	
--	22263GT	CONTACT, STATIONARY, 19549RELAY*		--	106122GT	CAP, DISENGAGE, 4HP/4HB*** <i>for 106148</i>	
--	74495GT	SPRING, RETURN (FOR 74268)		--	106123GT	O-RING, END COVER, 4HP/4HB*** <i>for 106148</i>	
8	74267GT	CONTACTOR, DRIVE, 24V, 180A***.....	1	--	106124GT	LINING KIT, BRAKE, 4HP*** <i>for 106148</i>	
--	74468GT	SPRING, RETURN (FOR 74267)		--	106125GT	SEAL KIT, BRAKE, 4HP <i>for 106148 (inventory limited to stock on hand as component is no longer available)</i>	
--	74469GT	FIXED CONTACT (FOR 74267)		--	106126GT	BEARING KIT, 4HP <i>for 106148 (inventory limited to stock on hand as component is no longer available)</i>	
--	74470GT	MOVING CONTACT (FOR PN 74267)		--	1286600GT	SEAL KIT, WHEEL DRIVE (106148/106445/107712) <i>for 106148 (inventory limited to stock on hand as component is no longer available)</i>	
9	128337GT	CONTROLLER, SEPEX MOTOR, Z45DC/BE.....	1	--	1286602GT	SEAL KIT, WHEEL DRIVE W/BRAKE (101584/101585) <i>for 106148</i>	
--	1263554GT	PROGRAMMER, PMC 1313K-4401		--	1286603GT	BEARING KIT, WHEEL DRIVE W/BRAKE (101584/101585) <i>for 106148</i>	
--	128598GT	HARNESS RETRO 24V RELAY		--	146051GT	BEARING NUT*** <i>for 106148</i>	
--	56561GT	TOOL, TERMINAL CRIMPER, MOLEX***		--	146052GT	SET SCREW*** <i>for 146051</i>	
--	56562GT	TOOL, TERMINAL EXTRACTOR, MOLEX		--	215777GT	INPUT CARRIER, SUB-ASSEMBLY <i>for 106148</i>	
10	70657GT	PLATE, CONTACTOR MOUNT, Z45.....	1	--	232486GT	SNAP RING, WHEEL DRIVE <i>for 106148</i>	
11	6708GT	SCREW, HHC, 3/8-16 X 2.25		--	58320GT	KIT, TORQUE HUB COVER(101584)** <i>for 106148</i>	
12	6021GT	WASHER, LOCK, .375		--	9990074GT	COUPLING <i>for 106148 (brake coupler)</i>	
13	5397GT	WASHER, FLAT, USS, 5/16", Y					
14	50668-SGT	BAR, AXLE ROTATION STOP.....	2				
15	54542GT	PIN, 1.50DIA X 2.00LG, CHAMFER.....	2				
16	825019GT	ROD END, .375X3.69, ZAG.....	1				
17	4828GT	NUT, NYLOCK, 3/8-16					
18	110737GT	AXLE ASSY, NON-STR, NARROW BASE.....	1 <i>to SN 31771</i>				
--	119980GT	AXLE ASSY, REAR, NARROW Z45/Z51 <i>from SN 31772</i>					
--	45071GT	BEARING, 1.5IDX1.75ODX1.5L					
19	19418GT	SCREW, SHC, 5/8-11 X 1.75					
20	13064GT	WASHER, FLAT, .625 HARDENED					
21A	139351GT	BRAKE, NEMA, 1200 IN/LB.....	2				
--	139353GT	STACK KIT, AUSCO 1200 IN/LB <i>for 139351</i>					
--	139354GT	O-RING KIT, AUSCO 1200 IN/LB <i>for 139351</i>					
--	139355GT	GASKET KIT, AUSCO 1200 IN/LB <i>for 139351</i>					
--	65608GT	BEARING KIT, AUSCO*** <i>for 139351</i>					

202.1 Non-steer End
(continued)

Item	Part No.	Description	Qty.	Item	Part No.	Description	Qty.
22B	218570GT	WHEEL DRIVE, NON-BRAKE, 47.6:1.....2 <i>(verify component before ordering) (Do Not use with 106148)</i>		--	147187GT	BRUSH KIT, DRIVE MOTOR <i>for AMD motor 56282</i>	
--	139965GT	WHEEL STUD,5/8-18,OMNI*** <i>for 218570</i>		--	37189GT	SPRING, BRUSH RETAINER, 36182* <i>for AMD motor 56282</i>	
--	139966GT	ROD,DISCONNECT,OMNI*** <i>for 218570</i>		--	44778GT	BEARING,MOTOR,36843,BRUSH END* <i>for AMD motor 56282</i>	
--	139967GT	CAP,DISENGAGE,OMNI*** <i>for 218570</i>		--	62105GT	BRUSH HOLDER(56282) <i>for AMD motor 56282</i>	
--	139968GT	O-RING,END COVER,OMNI*** <i>for 218570</i>		25	1283806GT	AXLE COVER,NARROW.....1	
--	147034GT	PIPE PLUG KIT,OMNI*** <i>for 218570</i>		26	8915GT	SCREW,HHC,1/4-20 X 1.25	
--	229833GT	BEARING KIT, OMNI <i>for 218570</i>		27	6091GT	NUT,NYLOCK,1/4-20	
--	229834GT	SEAL KIT, OMNI <i>for 218570</i>		28	8914GT	SCREW,HHC,1/4-20 X .625	
--	58531GT	ORING,568-908 N552-90 NBR,10PK <i>for 218570</i>		29	49818GT	SCREW,PHILLIPS,PHM,10-32 X .38	
23A	1267780GT	TIRE/WH ASSY,9 LG,FOAM,NS REAR.....2 <i>(non-steer end)</i>		30	6607GT	WASHER,LOCK,#10 PLTD	
23B	1267782GT	TIRE/WH ASSY,9LG,NM,FOAM,NS RE <i>(non-steer end)</i>		31	74266GT	CONTACTOR,LIFT PUMP 24V 180A**...1	
23C	1267785GT	TIRE/WH ASSY,9 LG,REPNEU,NS <i>(non-steer end)</i>		--	62695GT	CONTACT,STATIONARY (56434)**	
23D	1267787GT	TIRE/WH ASSY,9 LG,NM,REPNEU,NS <i>(non-steer end)</i>		--	62696GT	CONTACT-MOVEABLE (56434)**	
24A	T108673GT	KIT, 24V SEP-EX DRIVE MOTORS <i>Replacement kit for GE motor 94197; check stamp on part prior to ordering (kit contains qty 2 x 56282 motor)</i>		--	74471GT	SPRING,RETURN (74266)	
--	147187GT	BRUSH KIT, DRIVE MOTOR <i>for AMD motor 56282</i>		32	13002GT	SCREW,HHC,5/16-18 X 1 GR5	
--	37189GT	SPRING, BRUSH RETAINER, 36182* <i>for AMD motor 56282</i>		33	6886GT	WASHER,LOCK,.313	
--	44778GT	BEARING,MOTOR,36843,BRUSH END* <i>for AMD motor 56282</i>		34	18503GT	NUT,LOCKING-LG.FLANGE,5/16-18	
--	56282GT	MOTOR,SEP-EX,24V*** <i>AMD motor; check stamp on part prior to ordering</i>		35	43179GT	FUSE,500 AMP,VERY FAST ACTING.....1	
--	62105GT	BRUSH HOLDER(56282) <i>for AMD motor 56282</i>		36	50576GT	SCREW,SHC,1/2-13 X 3.00	
24B	94315GT	BRUSH KIT,GE DRIVE MOTOR*** <i>for GE motor 94197; check stamp on part prior to ordering</i>		37	77677GT	SCREW,PHILLIPS,PHM,10-24 X 1	
24B	94316GT	BRUSH RETAINING SPRING,DR MTR <i>for GE motor 94197; check stamp on part prior to ordering</i>		38	73575GT	SPRING CLIP,10-24,.025-.125X.468,ZAG	
24B	94317GT	BEARING KIT,GE DRIVE MOTOR*** <i>for GE motor 94197; check stamp on part prior to ordering</i>		39	56912GT	SPRING CLIP,1/4-20,.025-.15X.54,ZAG	
24C	56282GT	MOTOR,SEP-EX,24V*** <i>check stamp on part prior to ordering</i>		40	56930GT	DIODE,PCB DRIVE CONTACTOR**.....1	
				41	50669GT	SHIM,AXLE ROTATION STOP,22GA.....as-needed to SN 29757	
				--	119209GT	SHIM,AXLE ROTATION STOP,22GA.....as-needed from SN 29758	
				42	119210GT	SHIM,AXLE ROTATION STOP,12GA.....as-needed to SN 29757	
				--	119210GT	SHIM,AXLE ROTATION STOP,12GA.....as-needed from SN 29758	
				43	36372GT	FUSE,50 AMP,VERY FAST ACTING.....1 <i>DC models with Inverter</i>	
				44	66717GT	FUSE BLOCK, ANN & ANL FUSE.....1 <i>DC models with Inverter</i>	
				45	6782GT	NUT,NYLOCK,5/16-18.....2 <i>for 36372</i>	
				46	17626GT	SCREW,FHM,10-32 X .75.....2 <i>for 66717</i>	



202.1 Non-steer End
(continued)

Item	Part No.	Description	Qty.
47	79452GT	CONVERTER, DC-DC, 48-26 VOLT**1 <i>from SN Z452513A-48153 and from Z452513B-3078 (mounting hardware not included)</i>	
--	6146GT	WASHER,FLAT,MS,#10,Y.....4 <i>(not shown, not included)</i>	
--	6607GT	WASHER,LOCK,#10 PLTD.....4 <i>(not shown, not included)</i>	
--	73575GT	SPRING CLIP,10-24,.025-.125X.468,ZAG.....4 <i>(not shown, not included)</i>	
--	73587GT	SCREW,PHIL,10-24 X .75.....4 <i>(not shown, not included)</i>	

203.1 Battery Packs

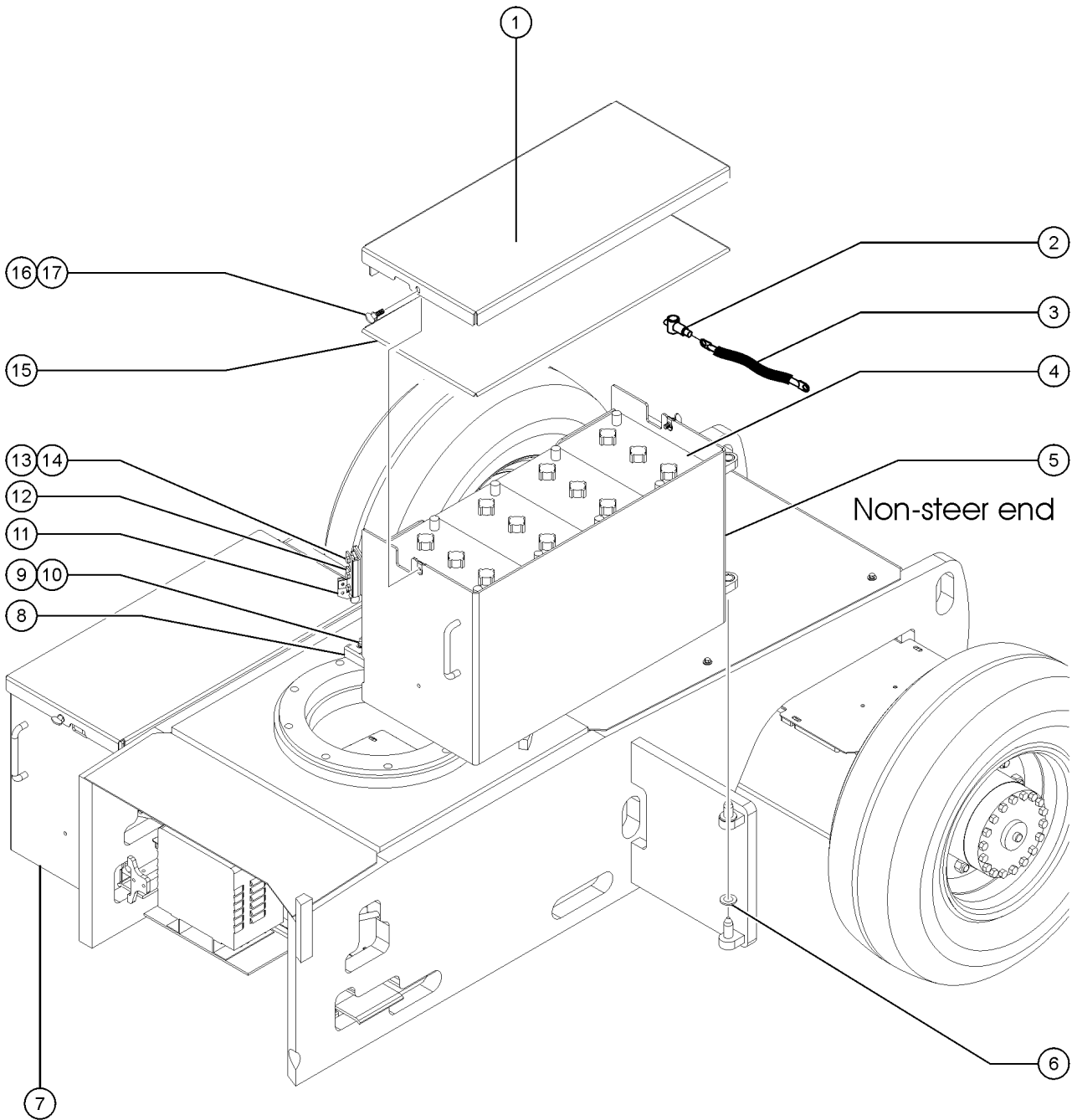

Item	Part No.	Description	Qty.
1	94001GT	LID-BATTERY BOX W/DECALS**.....2	
2	51147GT	BOOT,CABLE TERMINAL,LG,RED,2/0...4	
3	19520GT	BATTERY CABLE ASSY,9.5"JUMPER...6	
4A	36579GT	BATTERY, 350AH,GROUP L16G(DRY).....8	
4B	823684GT	BATTERY,AGM,6V/390A,L16.....8 <i>models with AGM option from SN 46035</i>	
5A	94003GT	BATTERY BOX ASSY,CONTRL SIDE**.....1 <i>includes items 1, 8, 11, 12, 16 & 17, to SN Z452513A-48672</i>	
--	36369GT	BEARING,0.75IDX1.00ODX0.75L.....2	
5B	161941GT	BATTERY BOX ASSY, LH <i>decal not included, refer to section 100, from SN Z452513A-48673</i>	
--	36369GT	BEARING,0.75IDX1.00ODX0.75L.....2	
6	36212GT	WASHER,THRUST,.75 X 1.38X.13	
7A	94002GT	BATTERY BOX ASSY,TANK SIDE***.....1 <i>includes items 1, 8, 11, 12, 16 & 17, to SN Z452513A-48672</i>	
--	36369GT	BEARING,0.75IDX1.00ODX0.75L.....2	
7B	161940GT	BATTERY BOX ASSY, RH <i>decal not included, refer to section 100, from SN Z452513A-48673</i>	
--	36369GT	BEARING,0.75IDX1.00ODX0.75L.....2	
8	45209GT	WEAR PAD,4X2X.5 W/INSERT***.....2	
9	6888GT	SCREW,HHC,1/4-20 X 1	
10	6638GT	WASHER,FLAT,USS,1/4"Y	
11A	66900GT	LATCH,ROTARY, W/KNOB,LEFT.....1 <i>installed on LEFT side of chassis</i>	
11B	66901GT	LATCH,ROTARY, W/KNOB,RIGHT.....1 <i>(shown) installed on LEFT side of chassis</i>	
12A	101425PGT	FORMING,BATTERY BOX LATCH LH....1 <i>(shown)</i>	
12B	101426PGT	FORMING,BATTERY BOX LATCH RH....1	
13	13000GT	SCREW,HHC,5/16-18 X 1.25	
14	6002GT	NUT,LP NYLOCK,5/16-18	
15	106241GT	INSULATION,48V BATT.BOX LID.....2 <i>models with AGM option from SN 46035</i>	
16	824228GT	SCREW,THUMB,A-REG,3/8-16X1,ZAG	
17	29868GT	SPRING CLIP,3/8-16,.05-.20X.73,ZAG	

204.1 Battery Charger

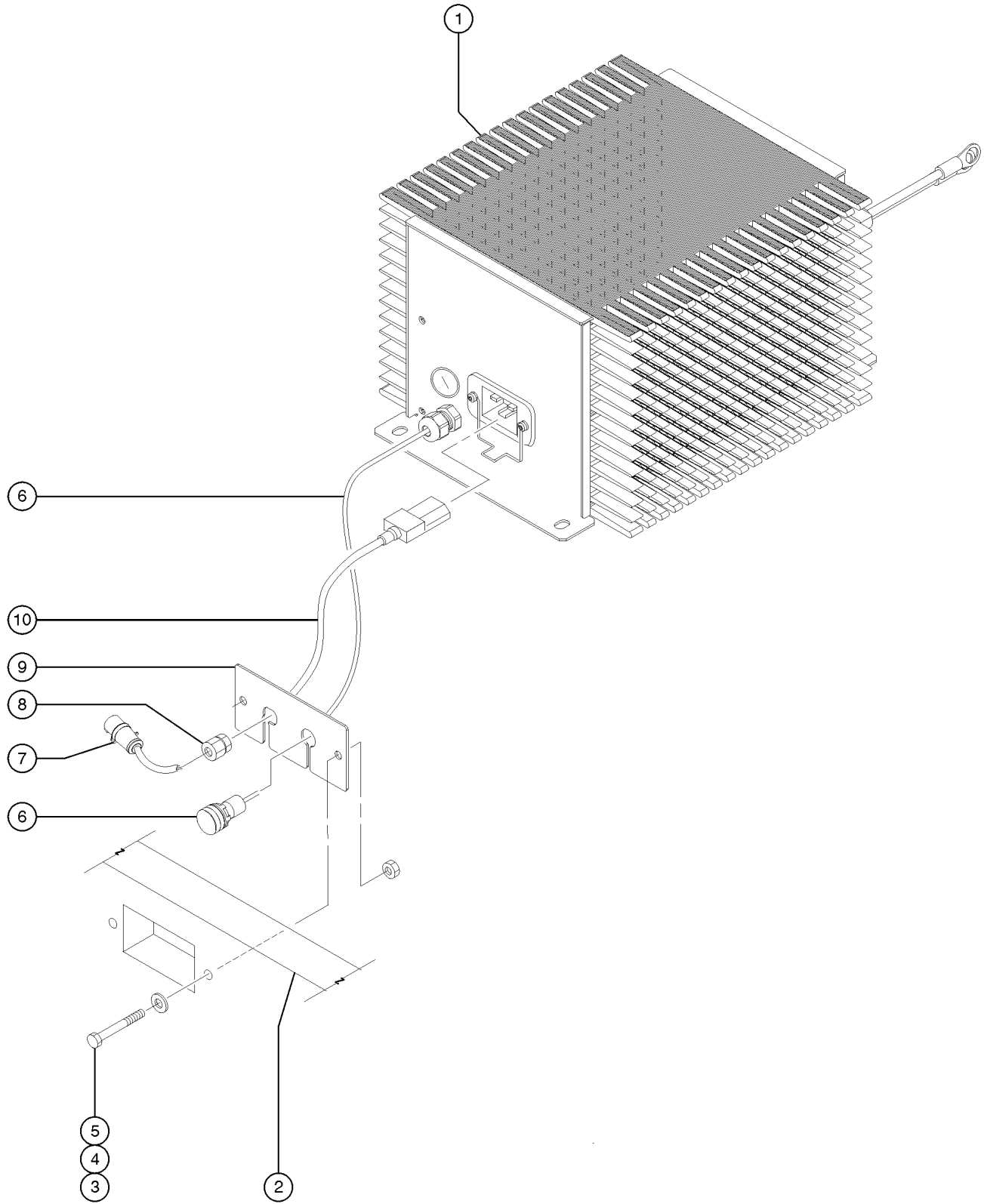

204.1 Battery Charger

Item	Part No.	Description	Qty.
--	228946GT	ASSY,LED,IES CHARGER	
--	228947GT	CLIP,RETAINING,IES CHARGER	
1	128375GT	CHARGER 48V/30A AUTO AC X-LED....1 <i>(includes item 6) (order power cord separately)</i>	
--	133286GT	DECAL, POWER TO CHARGER, UNIV.....1	
--	139857GT	HARN.CHARGER INTERLOCK Z45.....1 <i>(not shown)(option)</i>	
2		Ref. Chassis	
3	6326GT	SCREW,HHC,3/8-16 X 3	
4	6097GT	WASHER,FLAT,USS,3/8",Y	
5	4828GT	NUT,NYLOCK,3/8-16	
6	228973GT	KIT,ASSY,LED,IES CHARGER.....1	
7A	1280665GT	PLUG, TYPE F, 230A, 50HZ, 16A, IP44.....1 <i>Euro 220V</i>	
7B	144161GT	PLUG,PWR,UK,16AMP,3PIN,BLK <i>UK 110V</i>	
7C	25388GT	PLUG,FUSED,250V,13AMP,U.K.** <i>UK 220V</i>	
8A	128118GT	BUSHING,STRAIN RELIEF,.875/.40 <i>(domestic)</i>	
8B	139318GT	BUSHING,STRAIN RELIEF,.875/.30 <i>(UK)</i>	
9	128825GT	BRACKET, CHARGER CORD AND LED	
10A	128645GT	CORD AC IEC320-C19 TO 220EU <i>EU 220V</i>	
10B	128377GT	CORD AC IEC320-C19 TO 110US <i>US 110V</i>	

205.1 Power Cables

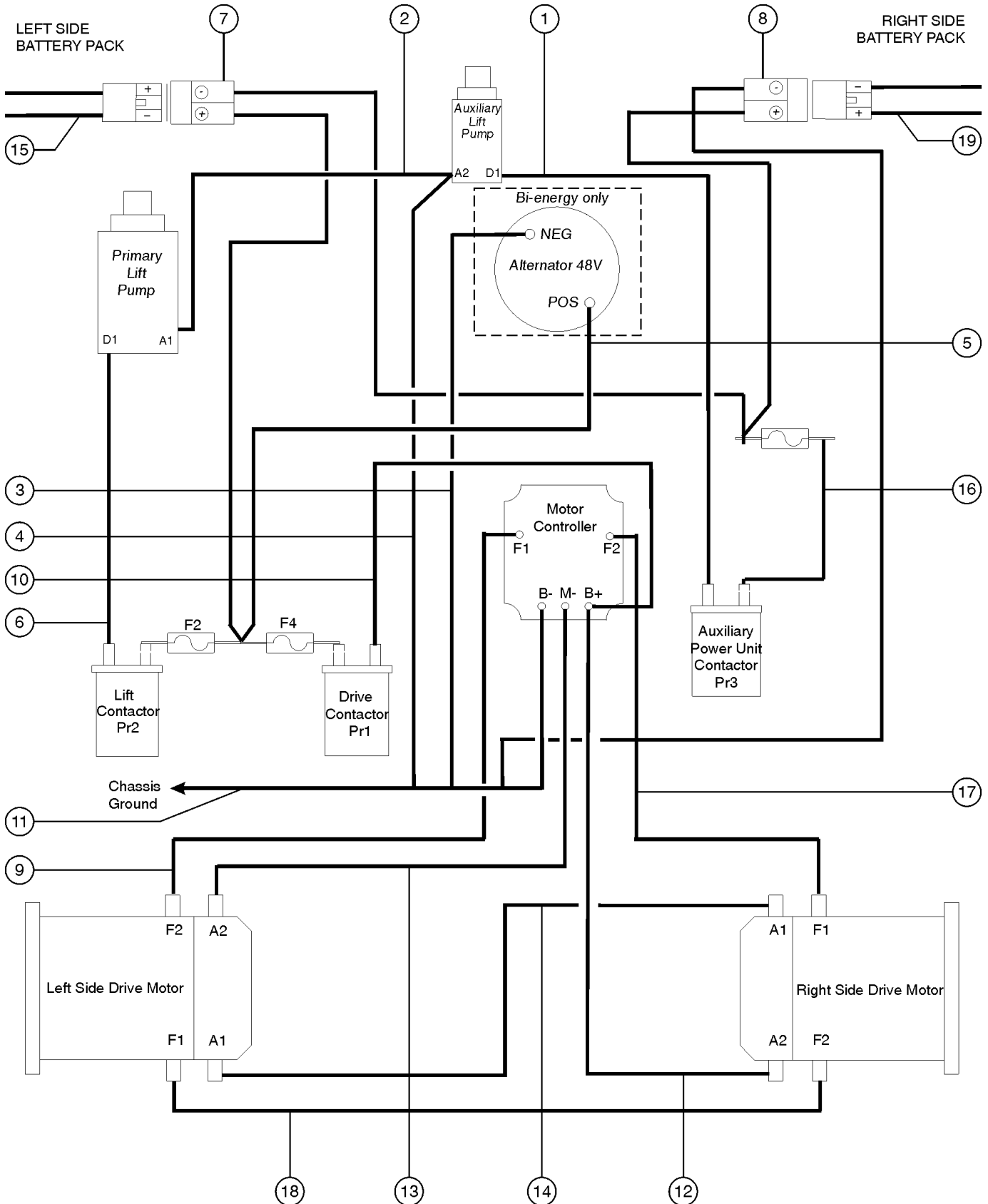

205.1 Power Cables

Item	Part No.	Description	Qty.	Item	Part No.	Description	Qty.
--	51147GT	BOOT,CABLE TERMINAL,LG,RED,2/0		--	128466GT	CABLE ASSY #2 BLK AP1/AP2 BATT	
1	139058GT	CABLE ASSY #2 RED PR3/AP-DI.....1	1				
2	139049GT	CABLE ASSY #2 BLK AP-A2/LP-A1.....1	1				
3	139063GT	CABLE ASSY #2 BLK ALT(-)/GND.....1 <i>Bi-Energy only</i>	1				
4	139052GT	CABLE ASSY #2 BLK AP-A2/GND.....1	1				
5	139064GT	CABLE ASSY #2 RED ALT(+)/F2.....1 <i>Bi-Energy only</i>	1				
6	139057GT	CABLE ASSY #2 RED PR2/LP-D1.....1	1				
7A	139048GT	HARN ASSY,POWER PACK AP2.....1 <i>DC only</i>	1				
--	128488GT	CABLE ASSY #2 RED AP1/FU1 DRIV					
--	128489GT	CABLE ASSY #2 BLK AP1/AP2 DRIV					
7B	139062GT	HARN ASSY,POWER DRIVE CHASS <i>Bi-Energy only</i>					
--	128491GT	CABLE ASSY #2 RED AP2/FU2 DRIV					
--	128492GT	CABLE ASSY #2 BLK AP2/FU1 DRIV					
8	139047GT	HARN ASSY,POWER PACK AP1.....1	1				
--	128490GT	CABLE ASSY #2 RED AP2/FU1.....1	1				
--	128929-300GT	SHRINK TUBE, BLACK 3/4,3:1.....1	1				
--	51147GT	BOOT,CABLE TERMINAL,LG,RED,2/0...2					
--	66397GT	QUICK DISCONNECT CASING,BATT**1	1				
--	824049GT	CABLE ASSY #2 BLK AP1/AP2 DRIV.....1	1				
9	139020GT	WIRE ASSY #10 RED F1/F2.....1	1				
10	139054GT	CABLE ASSY #2 RED B(+)/PR1.....1	1				
11	139050GT	CABLE ASSY #2 BLK B(-)/GND.....1	1				
12	139051GT	CABLE ASSY #2 BLK B(+)/A2.....1	1				
13	139055GT	CABLE ASSY #2 RED M(-)/A2.....1	1				
14	139056GT	CABLE ASSY #2 RED A1/A1					
15A	139011-SGT	SERV KIT,HARN ASSY,PWR BATT PK.....1 <i>DC only</i>	1				
--	128465GT	CABLE ASSY #2 RED BATT					
--	128466GT	CABLE ASSY #2 BLK AP1/AP2 BATT					
15B	139041GT	HARN ASSY, POWER PACK AP2.....1 <i>Bi-Energy only; left side</i>	1				
--	128486GT	CABLE ASSY #2 RED AP2 BATT					
--	128487GT	CABLE ASSY #2 BLK BE AP2 BATT					
16	139053GT	CABLE ASSY #2 RED PR2/F2.....1	1				
17	139059GT	WIRE ASSY #10 RED F2/F1.....1	1				
18	139060GT	WIRE ASSY #10 RED F1/F2.....1	1				
19	139011-SGT	SERV KIT,HARN ASSY,PWR BATT PK.....1 <i>Bi-Energy only; right side</i>	1				
--	128465GT	CABLE ASSY #2 RED BATT					

301.1 Turntable Rotator

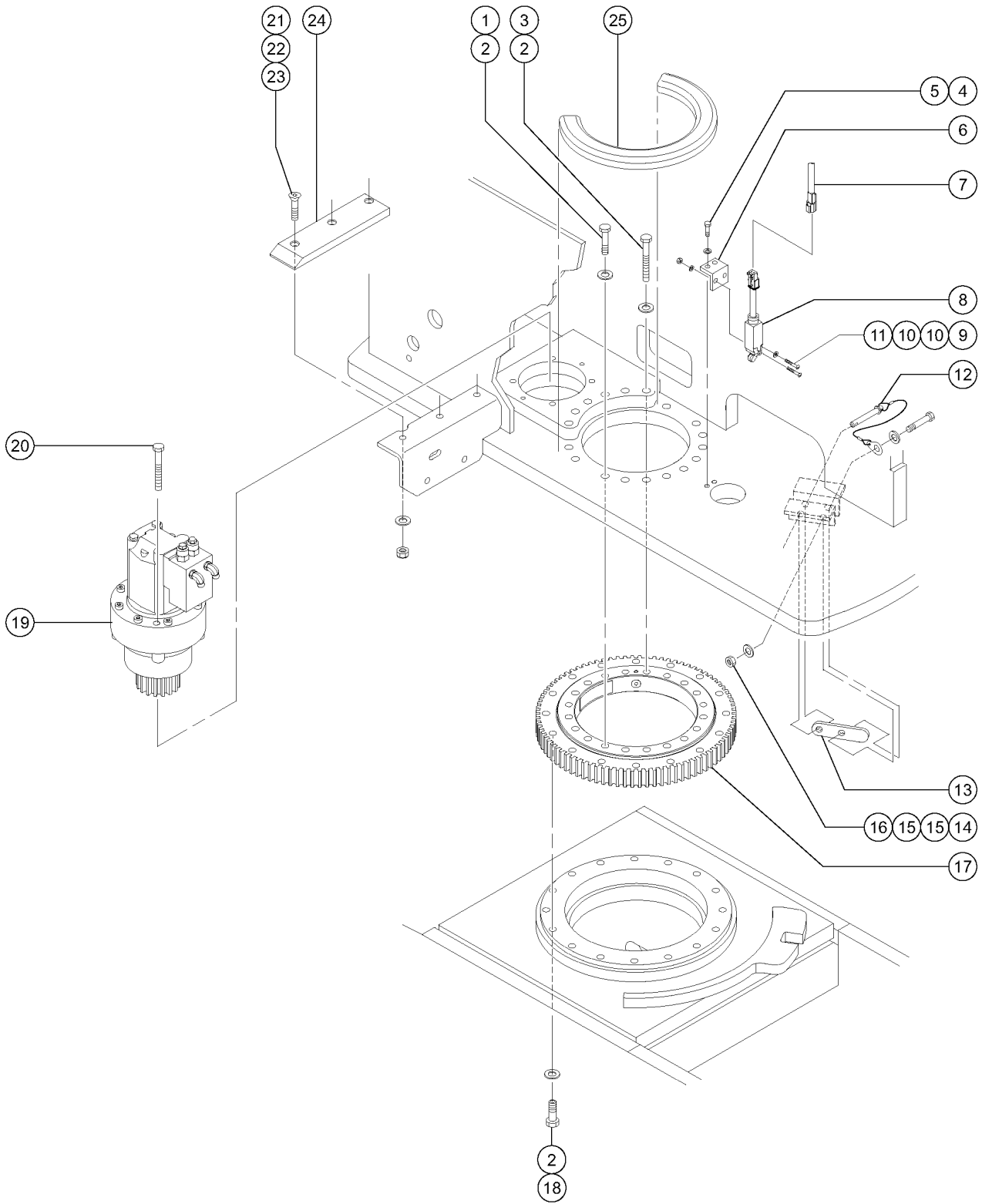

301.1 Turntable Rotator

Item	Part No.	Description	Qty.	Item	Part No.	Description	Qty.
1A	74712GT	SCREW,SHC,5/8-11 X 2.75,A574.....12 to SN 38872	12	--	147210GT	SEAL KIT,SWING DRIVE*** for 147209; from SN Z452511A-40411 to Z452514A-50078 and to Z452514B-3302	
1B	139861GT	SCREW,HHC,5/8-11 X 2.75 GR8 BO....12 from SN 38873	12	--	147211GT	BRAKE KIT, SWING DRIVE for 147209; from SN Z452511A-40411 to Z452514A-50078 and to Z452514B-3302	
2	13064GT	WASHER,FLAT,.625 HARDENED.....36	36	--	147212GT	MANIFOLD KIT, SW DRIVE for 147209; from SN Z452511A-40411 to Z452514A-50078 and to Z452514B-3302	
3A	21175GT	SCREW,SHC,5/8-11 X 4,A574.....6 to SN 38872	6	--	220255GT	SEAL KIT,MANIFOLD TO MOTOR for 147212; from SN Z452511A-40411 to Z452514A-50078 and to Z452514B-3302	
3B	139865GT	SCREW,HHC,5/8-11 X 4.00 GR8 BO....6 from SN 38873	6	--	48904GT	ELBOW,90D,520220-4-4 not included, must order seperately	
4	8255GT	SCREW,HHC,3/8-16 X .75		19C	824050GT	SWING DRIVE ASSEMBLY from SN Z452514A-50079 and Z452514B-3303	
5	6021GT	WASHER,LOCK,.375		--	48904GT	ELBOW,90D,520220-4-4 not included, must order seperately	
6	50469GT	BRACKET,DRIVE SENSOR,ENABLE.....1	1	--	824051GT	SEAL KIT, SWING DRIVE for 824050; from SN Z452514A-50079 and Z452514B-3303	
7	88719GT	HARNESS,FUNCTION,Z45 DC/BI		--	824052GT	VALVE BLOCK, SWING DRIVE for 824050; from SN Z452514A-50079 and Z452514B-3303	
8	88356-11103GT	SWITCH,LIMIT,W/RLR ARM,NO/NC**....1	1	20	56680GT	SCREW,SHC,1/2-13 X 4.50 ZINC	
--	106427GT	LS ROT.HEAD W/O LEVER (ZCE01)		21	17712GT	SCREW,FHS,3/8-16 X 1.75	
--	110160GT	HARNESS,LS,D.E. Z45		22	5397GT	WASHER,FLAT,USS,5/16",Y	
--	97128GT	ROLLER ARM,LIMIT SWITCH***		23	4828GT	NUT,NYLOCK,3/8-16	
9	51063GT	SCREW,PHILLIPS,RHM,10-32 X 1.5		24	50519GT	LOAD PAD,ENGINE TRAY SUPPORT....1	
10	6146GT	WASHER,FLAT,MS,#10,Y		25	107651GT	PROTECTOR,SLEW BOLT.....1	
11	6178GT	NUT,NYLOCK,10-32					
12	54145-800GT	RETAINING PIN, ASSY.....1	1				
13	50776PGT	PLATE,SWING LOCK,PAINTED***1	1				
14	6198GT	NUT,NYLOCK,1/2-13					
15	6095GT	WASHER,FLAT,USS,1/2",Y					
16	50576GT	SCREW,SHC,1/2-13 X 3.00					
17	101815GT	BEARING,SWING CHASSIS.....1	1				
--	88635-4024GT	HOSE ASSY 1/4,STR FEM,PIPETHRE..1	1				
18A	25068GT	SCREW,SHC,5/8-11 X 4.5,A574.....16 to SN 38872	16				
18B	139866GT	SCREW,HHC,5/8-11X4.50GR8 PLAIN.....16 from SN 38873	16				
19A		Ref: Swing Drive Assy (77082) component no longer available; used to SN Z452511A-40410					
--	128446GT	MANIFOLD,TURNTABLE ROTATION*** for 77082; to SN Z452511A-40410					
--	220255GT	SEAL KIT,MANIFOLD TO MOTOR for 128446; to SN Z452511A-40410					
--	48904GT	ELBOW,90D,520220-4-4 not included, must order seperately					
--	77246GT	SEAL KIT,SWING MOTOR*** for 77082; to SN Z452511A-40410					
19B		SWING DRIVE ASSY*** (147209) component no longer available; used from SN Z452511A-40411 to Z452514A-50078 and to Z452514B-3302					

302.1 Turntable Components - View 1

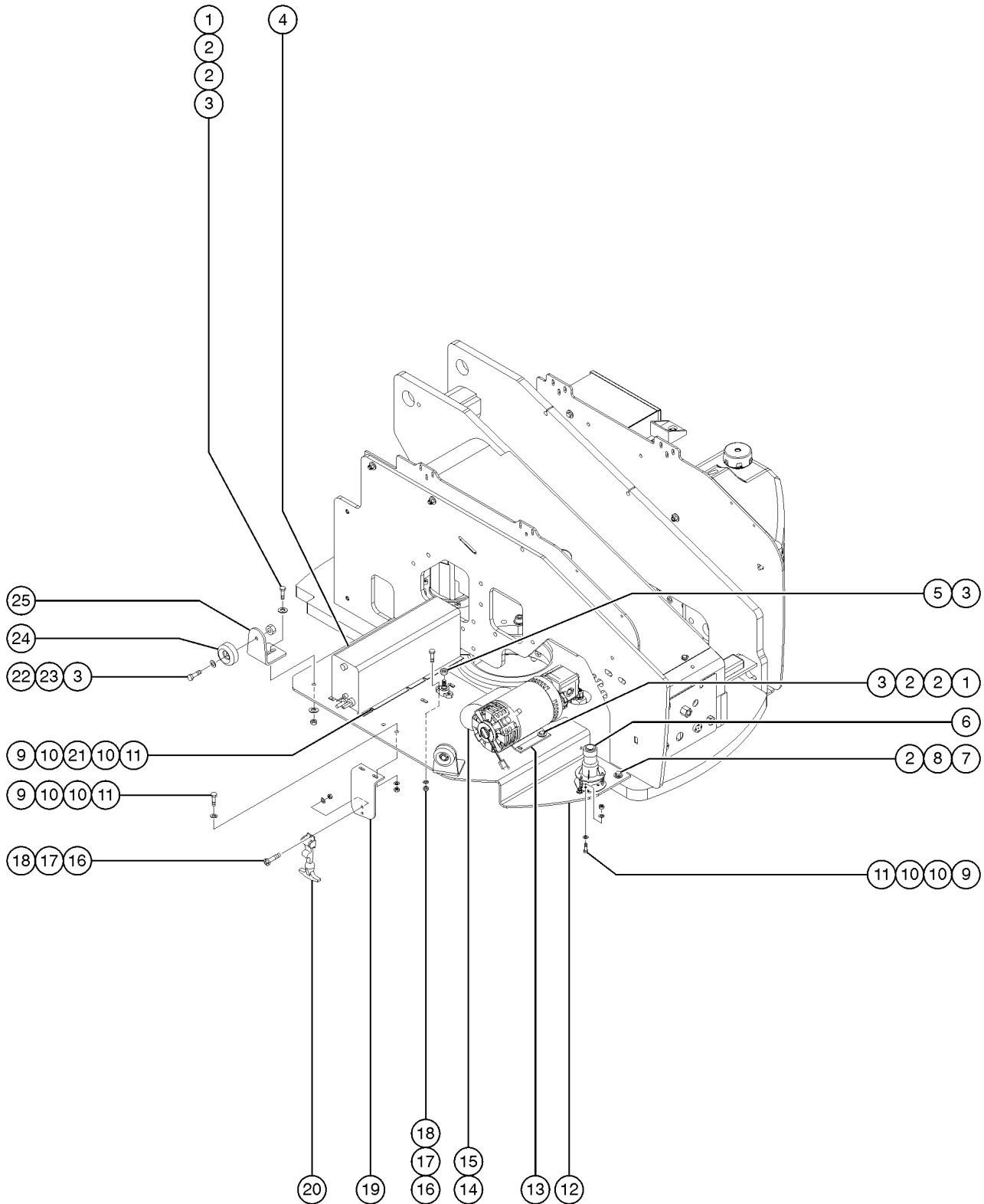

302.1 Turntable Components - View 1

Item	Part No.	Description	Qty.
1	6019GT	SCREW,HHC,3/8-16 X 1.25 GRD 5.....	6
2	6097GT	WASHER,FLAT,USS,3/8",Y.....	15
3	4828GT	NUT,NYLOCK,3/8-16.....	6
4	150026GT	INVERTER,48VDC,120VAC/60HZ.....	1
5A	94981GT	STUD,POWER 3/8" RED.....	1
		<i>red</i>	
5B	94982GT	STANDOFF, 3/8" BLACK.....	1
		<i>black</i>	
6	110382GT	LEVEL SENSOR,LS60,YL,2.5X4.5 CE	
6	94077GT	SENSOR,LEVEL,4.5 DEG.....	1
		<i>ANSI/CSA/Australia</i>	
7	8255GT	SCREW,HHC,3/8-16 X .75.....	3
8	6021GT	WASHER,LOCK,.375.....	3
--	37184GT	MOTOR, 24V (36179)	
--	37185GT	PUMP ASSEMBLY (36179)	
--	37186GT	VALVE,CHECK (36179)	
--	37187GT	SEAL KIT, 37185 PUMP <i>for 37185</i>	
--	37191GT	GASKET, PUMP / MOTOR (36179)	
--	37192GT	COUPLER, PUMP / MOTOR (36179)	
--	49878GT	NYLON WASHER,(36179)	
9	6888GT	SCREW,HHC,1/4-20 X 1.....	5
10	6638GT	WASHER,FLAT,USS,1/4"Y.....	10
11	6091GT	NUT,NYLOCK,1/4-20.....	5
12	60106PGT	FORMING,SWING CHASSIS TRAY PTD.....	1
13		HYDRAULIC POWER UNIT <i>Refer to 701.1</i>	
14	36179GT	POWER UNIT,AUX PUMP 24VDC.....	1
15	18506GT	SCREW 5/16-18 X .75 LG.FLG.LCK.....	2
16	6178GT	NUT,NYLOCK,10-32.....	3
17	6146GT	WASHER,FLAT,MS,#10,Y.....	3
18	49816GT	SCREW,PHILLIPS,PHM,10-32 X .75.....	3
19	128319GT	FORMING,DRAW LATCH MOUNT.....	1
20	45363GT	LATCH,FLEXIBLE DRAW W/O KEEPER.....	2
21	13268GT	CLAMP,0.75,#12 X 1/4,RUB CUSH.....	1
22	8516GT	SCREW, HCC, 3/8-16 X 1.50.....	2
23	5397GT	WASHER,FLAT,USS,5/16",Y.....	2
24	50974GT	BUMPER,RUBBER,COVERS.....	2
25	54363GT	BRACKET,RUBBER BUMPER,ENGCOVER.....	2

303.1 Turntable Components - View 2

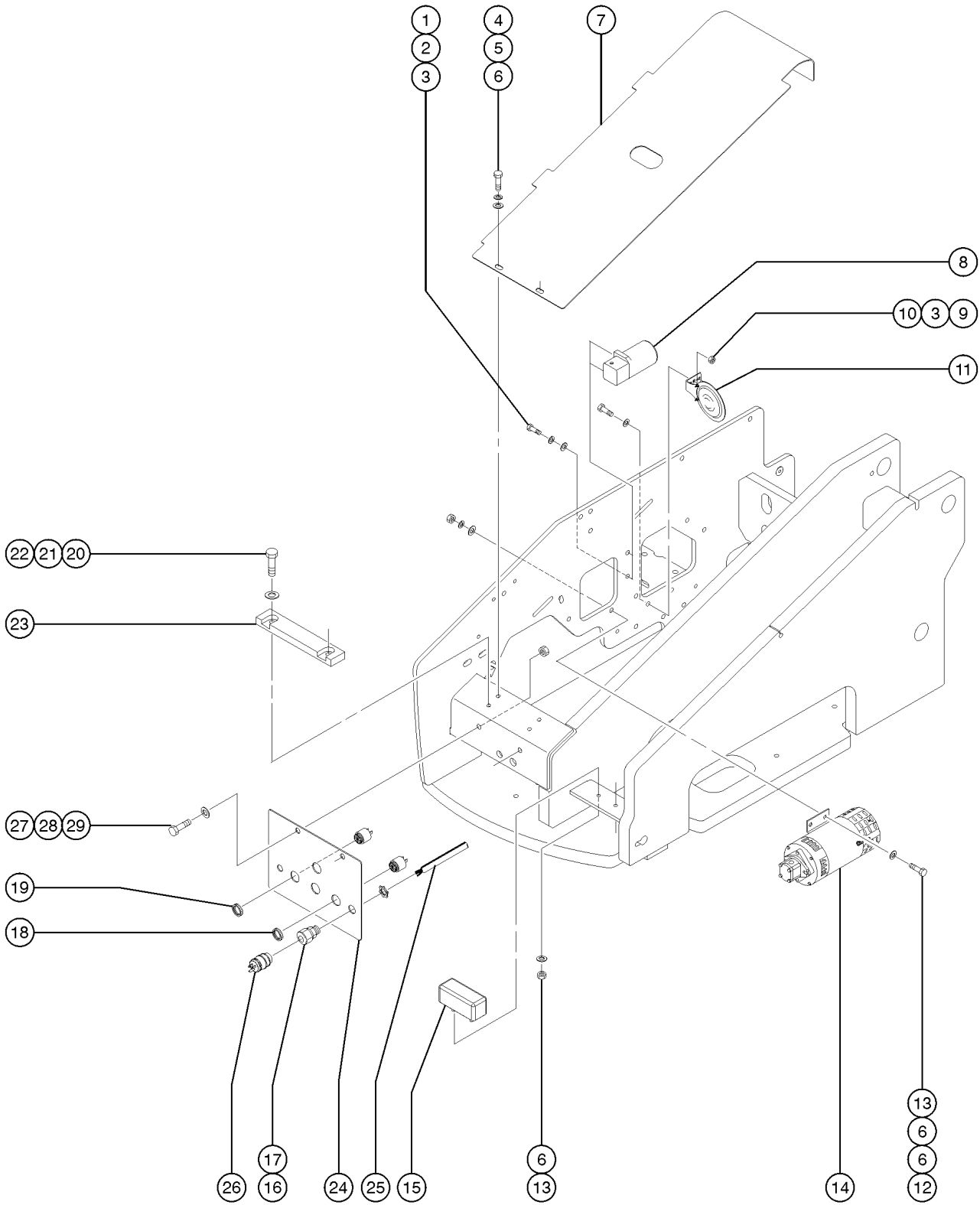

303.1 Turntable Components - View 2

Item	Part No.	Description	Qty.	Item	Part No.	Description	Qty.
1	13002GT	SCREW,HHC,5/16-18 X 1 GR5		--	119404GT	CONN,RECEP 120AC/15A DOMESTIC	
2	6886GT	WASHER,LOCK,.313		--	1280665GT	PLUG, TYPE F, 230A, 50HZ, 16A, IP44	
3	6638GT	WASHER,FLAT,USS,1/4"Y		--	144161GT	PLUG,PWR,UK,16AMP,3PIN,BLK	
4	8255GT	SCREW,HHC,3/8-16 X .75		--	25388GT	PLUG,FUSED,250V,13AMP,U.K.**	
5	6021GT	WASHER,LOCK,.375		26B	128646GT	CORD AC IEC320-C19 TO 110UK.....1 UK	
6	5397GT	WASHER,FLAT,USS,5/16",Y		--	139318GT	BUSHING,STRAIN RELIEF,.875/.30.....1	
7	70574PGT	COVER,CENTER SWING CHASSIS.....1 to SN 31386		26C	128645GT	CORD AC IEC320-C19 TO 220EU.....1 Europe	
--	119784PGT	COVER,CENTER SWING CHASSIS,PTD from SN 31387		--	139318GT	BUSHING,STRAIN RELIEF,.875/.30.....1	
8	36179GT	POWER UNIT,AUX PUMP 24VDC.....1		27	10597GT	SCREW,HHC,1/2-13 X 1.25 GR5	
--	37184GT	MOTOR, 24V (36179)		28	6095GT	WASHER,FLAT,USS,1/2",Y	
--	37185GT	PUMP ASSEMBLY (36179)		29	6198GT	NUT,NYLOCK,1/2-13	
--	37186GT	VALVE,CHECK (36179)					
--	37187GT	SEAL KIT, 37185 PUMP					
--	37191GT	GASKET, PUMP / MOTOR (36179)					
--	37192GT	COUPLER, PUMP / MOTOR (36179)					
--	49878GT	NYLON WASHER,(36179)					
9	6782GT	NUT,NYLOCK,5/16-18					
10	13000GT	SCREW,HHC,5/16-18 X 1.25					
11	81579GT	HORN,24VDC,SPADE TERMINALS***....1					
12	8516GT	SCREW, HCC, 3/8-16 X 1.50					
13	4828GT	NUT,NYLOCK,3/8-16					
14		Ref. Hydraulic Power Unit (refer to 701.1) Bi-energy models					
15	56927GT	PAD,REST,2"THICK,W/STUDS*.....1					
16	7056GT	CONN,SQUEEZE,1/2NPT .38-.50,SM....1					
17	6935GT	LOCKNUT,ELEC,1/2".....1					
18	18963GT	ALARM,INTERMITTENT TONE 6-30V*...1 Does not include 72326 nut					
--	72326GT	NUT - PLASTIC,RING FOR ALARMS.....1					
19	45462GT	ALARM,CHIME TONE 5-25VDC***1 Does not include 72326 nut					
--	72326GT	NUT - PLASTIC,RING FOR ALARMS.....1					
20	4828GT	NUT,NYLOCK,3/8-16					
21	5397GT	WASHER,FLAT,USS,5/16",Y					
22	8516GT	SCREW, HCC, 3/8-16 X 1.50					
23	50570GT	WEAR PAD,PRIMARY BOOM,NON JIB.....1					
24	70647PGT	PLATE,FRONT COVER PAINTED.....1					
25	43956GT	WIRE CABLE,14/3 CON.TPE JKT*.....756-inches					
26A	119403GT	CONN,PLUG 120 AC/15A DOMESTIC...1					
--		FUSE,13 AMP,220V PLUG (component no longer available) refer to BS1362 BUSS TDC180-13A					

304.1 Turntable Components - View 3

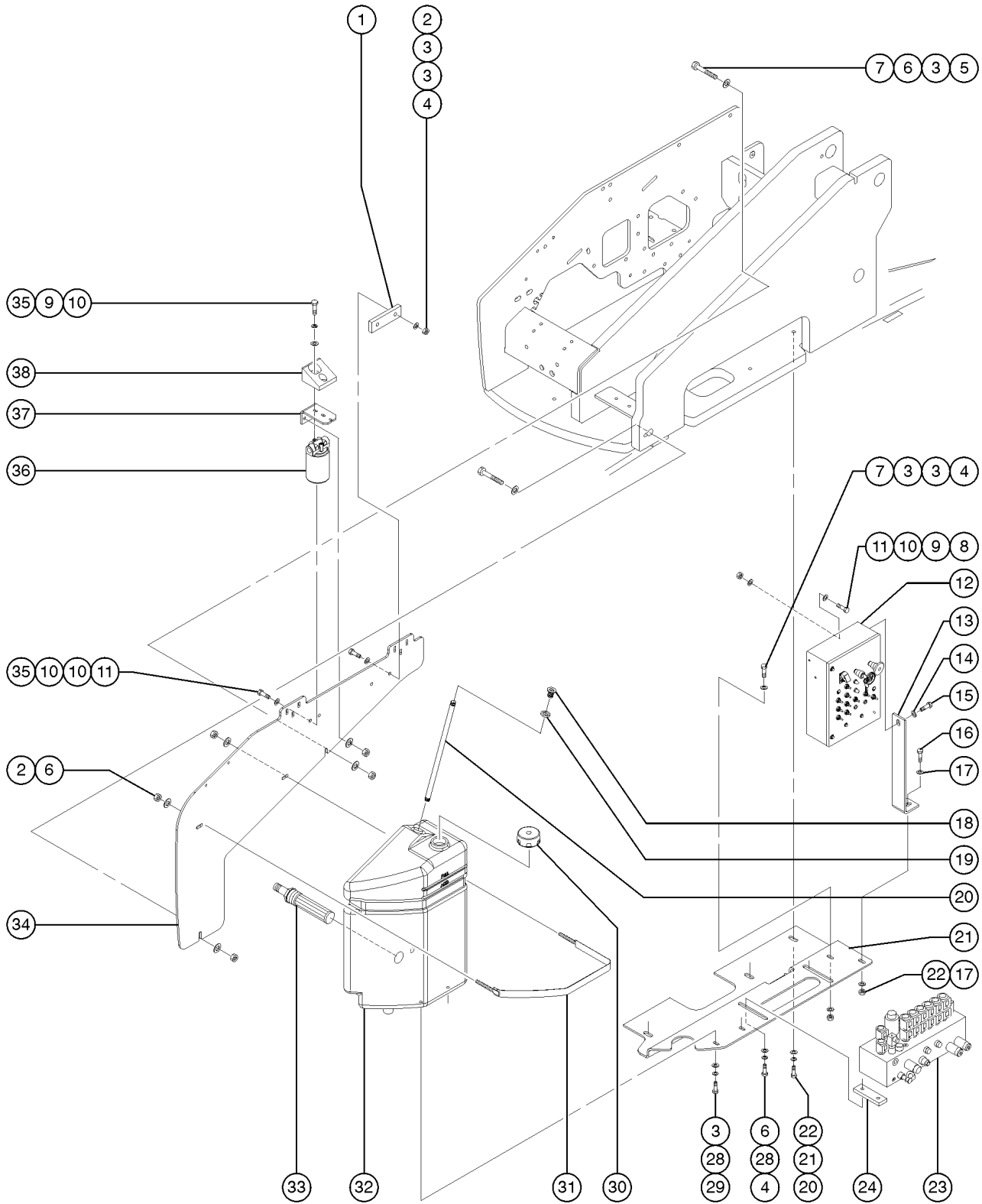

304.1 Turntable Components - View 3

Item	Part No.	Description	Qty.
1	54231GT	WEAR PAD,4.88 X 1.5 X .5.....1	
2	4828GT	NUT,NYLOCK,3/8-16	
3	5397GT	WASHER,FLAT,USS,5/16",Y	
4	6175GT	SCREW,HHC,3/8-16 X 1	
5	14033GT	SCREW,HHC,3/8-16 X 2.75	
6	6097GT	WASHER,FLAT,USS,3/8",Y	
7	7713GT	NUT, LP NYLOCK, 3/8-16	
8	6090GT	SCREW,HHC,1/4-20 X .75	
9	6356GT	WASHER,LOCK,.25	
10	6638GT	WASHER,FLAT,USS,1/4"Y	
11	6091GT	NUT,NYLOCK,1/4-20	
12		Ref. Ground Controls (refer to 405.1 or 406.1)	
13	88557GT	BRACKET,GROUND CONTROL BOX.....1	
14	6638GT	WASHER,FLAT,USS,1/4"Y	
15	6090GT	SCREW,HHC,1/4-20 X .75	
16	6175GT	SCREW,HHC,3/8-16 X 1	
17	5397GT	WASHER,FLAT,USS,5/16",Y	
18	39223GT	BULKHEAD FITTING,PLASTIC X 8**.....1 <i>Includes item 19</i>	
19	62088GT	WASHER/BULKHEAD***.....1	
20	60065GT	TUBE,PLASTIC .5 NPT X 18".....1	
21	50959-SGT	FORMING,SWING CHASSIS,RH,PAINT.....1	
22	7713GT	NUT, LP NYLOCK, 3/8-16	
23		Ref. Function Manifold <i>(refer to 702.1)</i>	
24	54231GT	WEAR PAD,4.88 X 1.5 X .5.....1	
25	10597GT	SCREW,HHC,1/2-13 X 1.25 GR5	
26	6033GT	WASHER,LOCK,0.5"	
27	6095GT	WASHER,FLAT,USS,1/2",Y	
28	6021GT	WASHER,LOCK,.375	
29	8255GT	SCREW,HHC,3/8-16 X .75	
30	42019GT	TANK BREATHER,NYLON **.....1	
31	77435GT	STRAP ASSY,29.25LG,W/RUBBER.....2	
32	50966GT	TANK,HYDRAULIC,8 GALLON,DC/BI.....1	
--	56022GT	PLUG,3/4 MAGNETIC PIPE SQ.DRV.....1	
33	45162GT	STRAINER ASSEMBLY,1.25" NPT***	
34	54443GT	BULKHEAD,SWING,RIGHT,Z45 DC/BE.....1	
35	6888GT	SCREW,HHC,1/4-20 X 1	
36	78622GT	FILTER ASSY,SAE8,10 MIC,PAPR**.....1	
--	44788GT	FILTER ELEMENT,10MICRON,PAPER*	
37	50744-SGT	BRACKET, RETURN FILTER.....1	
38	54360GT	CUP,PROP ROD,DC/BI.....1	

305.1 Ground Control Box - View 1

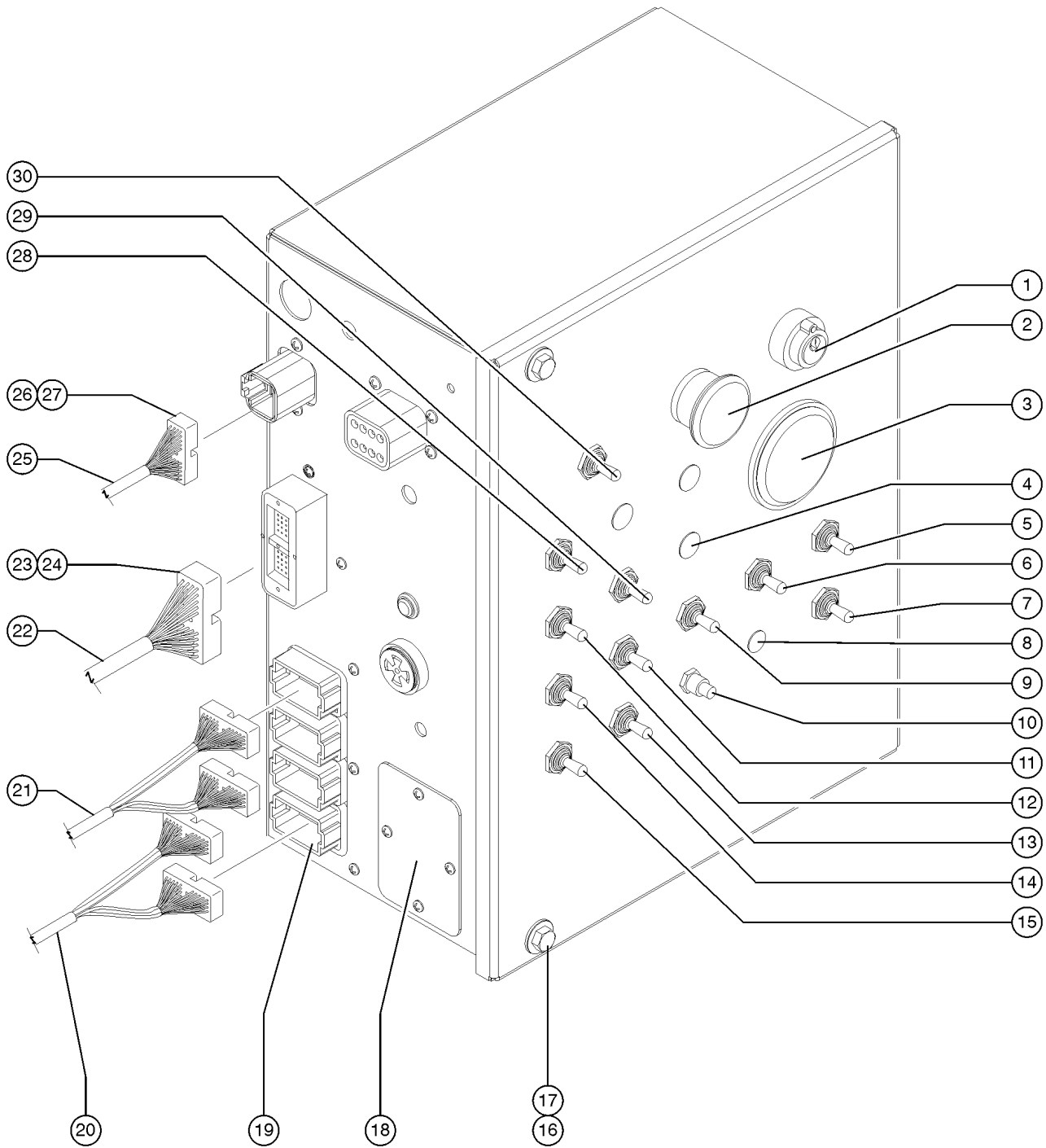

305.1 Ground Control Box - View 1

Item	Part No.	Description	Qty.	Item	Part No.	Description	Qty.
1A	96008-SGT	KEYSWITCH,3 POS. W/KEYS***.....1	1	9	128202GT	SWITCH TOGGLE ASSY DPDT 3P MOM.....1	1
--	21982GT	KEY,SINGLE***				<i>Secondary Boom Up/Down; includes boot and hardware</i>	
--	37947GT	KEYS,10 PACK***		--	128578GT	SCREW T-SWITCH PH/PH 6-32X1/4	
--	83093GT	KEY SINGLE*** <i>with rubber boot</i>		--	128582-SGT	SWITCH TOGGLE DPDT 3P MOM SHDR	
--	88827GT	GASKET,KEYSWITCH,PLASTIC***		--	27246GT	BOOT,TOGGLE SWITCH,SHORT*	
--	94506GT	BASE,W/3 NC CONTACTS		10	147094GT	ASSY, CIRCUIT BREAKER 15A.....1	1
1B	83131GT	KEYSWITCH,3 POS W/KEYS,LOCKING.....1	1			<i>includes mounting fasteners</i>	
--	83093GT	KEY SINGLE***		--	56234GT	O-RING,ORFS,-6	
--	85239GT	NUT,RETAINER (96008)		--	77061GT	BOOT,CIRCUIT BREAKER PROTECTOR	
2	66812GT	BUTTON,PUSH,RED MUSHROOM HEAD.....1	1	11A	229567GT	PLUG,SANTOPRENE .5 BLACK DOME (Z-45/25) from SN 41671	
--	66818GT	CONTACT, N.C.		11A	45384GT	PLUG,NYLON .50 BLACK DOMED.....1	1
--	73805GT	BASE,W/2 NC CONTACTS*** <i>includes 2 each N.C. contacts</i>		11B	128202GT	SWITCH TOGGLE ASSY DPDT 3P MOM.....1	1
3	19506GT	HOUR METER,10-80 VOLTS***1	1			<i>Jib Boom Up/Down (Z-45/25J); includes boot and hardware</i>	
		<i>includes mounting bracket</i>		--	128578GT	SCREW T-SWITCH PH/PH 6-32X1/4	
4	229567GT	PLUG,SANTOPRENE .5 BLACK DOME from SN 41671		--	128582-SGT	SWITCH TOGGLE DPDT 3P MOM SHDR	
4	45384GT	PLUG,NYLON .50 BLACK DOMED.....3	3	--	27246GT	BOOT,TOGGLE SWITCH,SHORT*	
		<i>from SN 27000 to 41670</i>		12	128202GT	SWITCH TOGGLE ASSY DPDT 3P MOM.....1	1
5	128200GT	SWITCH TOGGLE ASSY SPDT 3P MOM.....1	1			<i>Primary Boom Ext/Ret; includes boot and hardware</i>	
		<i>Glow Plug (Bi-Energy); includes boot and hardware</i>		--	128578GT	SCREW T-SWITCH PH/PH 6-32X1/4	
--	128578GT	SCREW T-SWITCH PH/PH 6-32X1/4		--	128582-SGT	SWITCH TOGGLE DPDT 3P MOM SHDR	
--	128580-SGT	SWITCH TOGGLE SPDT 3P MOM SHDR		--	27246GT	BOOT,TOGGLE SWITCH,SHORT*	
--	229567GT	PLUG,SANTOPRENE .5 BLACK DOME DC models from SN 41671		13	128202GT	SWITCH TOGGLE ASSY DPDT 3P MOM.....1	1
--	27246GT	BOOT,TOGGLE SWITCH,SHORT*				<i>Primary Level; includes boot and hardware</i>	
--	45384GT	PLUG,NYLON .50 BLACK DOMED.....1	1	--	128578GT	SCREW T-SWITCH PH/PH 6-32X1/4	
		<i>DC models from SN 27000 to 41670</i>		--	128582-SGT	SWITCH TOGGLE DPDT 3P MOM SHDR	
6	128200GT	SWITCH TOGGLE ASSY SPDT 3P MOM.....1	1	--	27246GT	BOOT,TOGGLE SWITCH,SHORT*	
		<i>Engine Start; includes boot and hardware</i>		14	128202GT	SWITCH TOGGLE ASSY DPDT 3P MOM.....1	1
--	128578GT	SCREW T-SWITCH PH/PH 6-32X1/4				<i>Turntable Rotate; includes boot and hardware</i>	
--	128580-SGT	SWITCH TOGGLE SPDT 3P MOM SHDR		--	128578GT	SCREW T-SWITCH PH/PH 6-32X1/4	
--	27246GT	BOOT,TOGGLE SWITCH,SHORT*		--	128582-SGT	SWITCH TOGGLE DPDT 3P MOM SHDR	
7	128200GT	SWITCH TOGGLE ASSY SPDT 3P MOM.....1	1	--	27246GT	BOOT,TOGGLE SWITCH,SHORT*	
		<i>Function Enable; includes boot and hardware</i>		15	128202GT	SWITCH TOGGLE ASSY DPDT 3P MOM.....1	1
--	128578GT	SCREW T-SWITCH PH/PH 6-32X1/4				<i>Platform Rotate; includes boot and hardware</i>	
--	128580-SGT	SWITCH TOGGLE SPDT 3P MOM SHDR		--	128578GT	SCREW T-SWITCH PH/PH 6-32X1/4	
--	27246GT	BOOT,TOGGLE SWITCH,SHORT*		--	128582-SGT	SWITCH TOGGLE DPDT 3P MOM SHDR	
8	21858GT	PLUG,NYLON .38 BLACK DOMED.....1	1	--	27246GT	BOOT,TOGGLE SWITCH,SHORT*	

305.1 Ground Control Box - View 1
(continued)

Item	Part No.	Description	Qty.	Item	Part No.	Description	Qty.
16	6090GT	SCREW,HHC,1/4-20 X .75		--	128582-SGT	SWITCH TOGGLE DPDT 3P MOM SHDR	
17	6638GT	WASHER,FLAT,USS,1/4"Y		--	27246GT	BOOT,TOGGLE SWITCH,SHORT*	
18	88691GT	COVER PLATE,CONNECTOR.....1 <i>shown; DC models</i>	1	30	128201GT	SWITCH TOGGLE ASSY DPDT 2P MOM.....1 <i>Auxiliary Power; includes boot and hardware</i>	1
--		HARNESS,ENGINE,Z45BI.....1 <i>Bi-Energy models; refer to section 410.1</i>	1	--	128578GT	SCREW T-SWITCH PH/PH 6-32X1/4	
--	73749GT	CONN,PLUG 24 WAY,DRC SERIES		--	128581-SGT	SWITCH TOGGLE DPDT 2P MOM SHDR	
--	73753GT	CONN,RECEP 24 WAY,W/FLANGE		--	25553GT	BOOT,TOGGLE SWITCH	
19	73736GT	CONN,RECEP 48 WAY,4 X 12.....1	1	--	27246GT	BOOT,TOGGLE SWITCH,SHORT*	
--	119061GT	CONN PLUG 12 WAY ENDCAP DT GY					
--	119062GT	CONN PLUG 12 WAY ENDCAP DT BK					
--	60435GT	LOCK,PLUG 12 WAY,14-18GA,GRN					
--	61801GT	SEAL DT SERIES-12W					
20A	88722-72000GT	HARNESS,18/19,BOOM CABLE #2.....1 <i>(non-jib); gray and black connectors</i>	1				
20B	88722-70700GT	HARNESS,18/19,BOOM CABLE #2 <i>(Z-45/25J)</i>					
--	119063GT	CONN PLUG 12 WAY ENDCAP DT GR					
--	119064GT	CONN PLUG 12 WAY ENDCAP DT BR					
--	60435GT	LOCK,PLUG 12 WAY,14-18GA,GRN					
--	61801GT	SEAL DT SERIES-12W					
21A	88721-72000GT	HARNESS,18/19 BOOM CABLE #1.....1 <i>(Z-45/25); brown and green connectors</i>	1				
21B	88721-70700GT	HARNESS,18/19 BOOM CABLE #1 <i>(Z-45/25J)</i>					
22	218154GT	HARN FUNCTION MAN Z45DC/BE.....1	1				
22	88719GT	HARNESS,FUNCTION,Z45 DC/BI.....1	1				
23	73751GT	CONN,PLUG 40 WAY,DRC SERIES.....1	1				
24	73754GT	CONN,RECEP 40 WAY,W/FLANGE.....1	1				
25A	88723-71000GT	HARNESS,12/3,12V TO PLAT.....1 <i>(Z-45/25)</i>	1				
25B	88723-69700GT	HARNESS,PLAT,Z45DC/BI,JIB <i>(Z-45/25J)</i>					
26	60527GT	CONN,PLUG 4 WAY,12-14GA.....1	1				
--	60528GT	LOCK,PLUG 4 WAY,12-14GA					
27	73754GT	CONN,RECEP 40 WAY,W/FLANGE.....1	1				
--	60526GT	LOCK,RECEP 4 WAY,12-14GA					
28	128202GT	SWITCH TOGGLE ASSY DPDT 3P MOM.....1 <i>Engine Idle; includes boot and hardware</i>	1				
--	128578GT	SCREW T-SWITCH PH/PH 6-32X1/4					
--	128582-SGT	SWITCH TOGGLE DPDT 3P MOM SHDR					
--	27246GT	BOOT,TOGGLE SWITCH,SHORT*					
29	128202GT	SWITCH TOGGLE ASSY DPDT 3P MOM.....1 <i>Primary Boom Up/Down; includes boot and hardware</i>	1				
--	128578GT	SCREW T-SWITCH PH/PH 6-32X1/4					



This Page Intentionally Left Blank

306.1 Ground Control Box - View 2

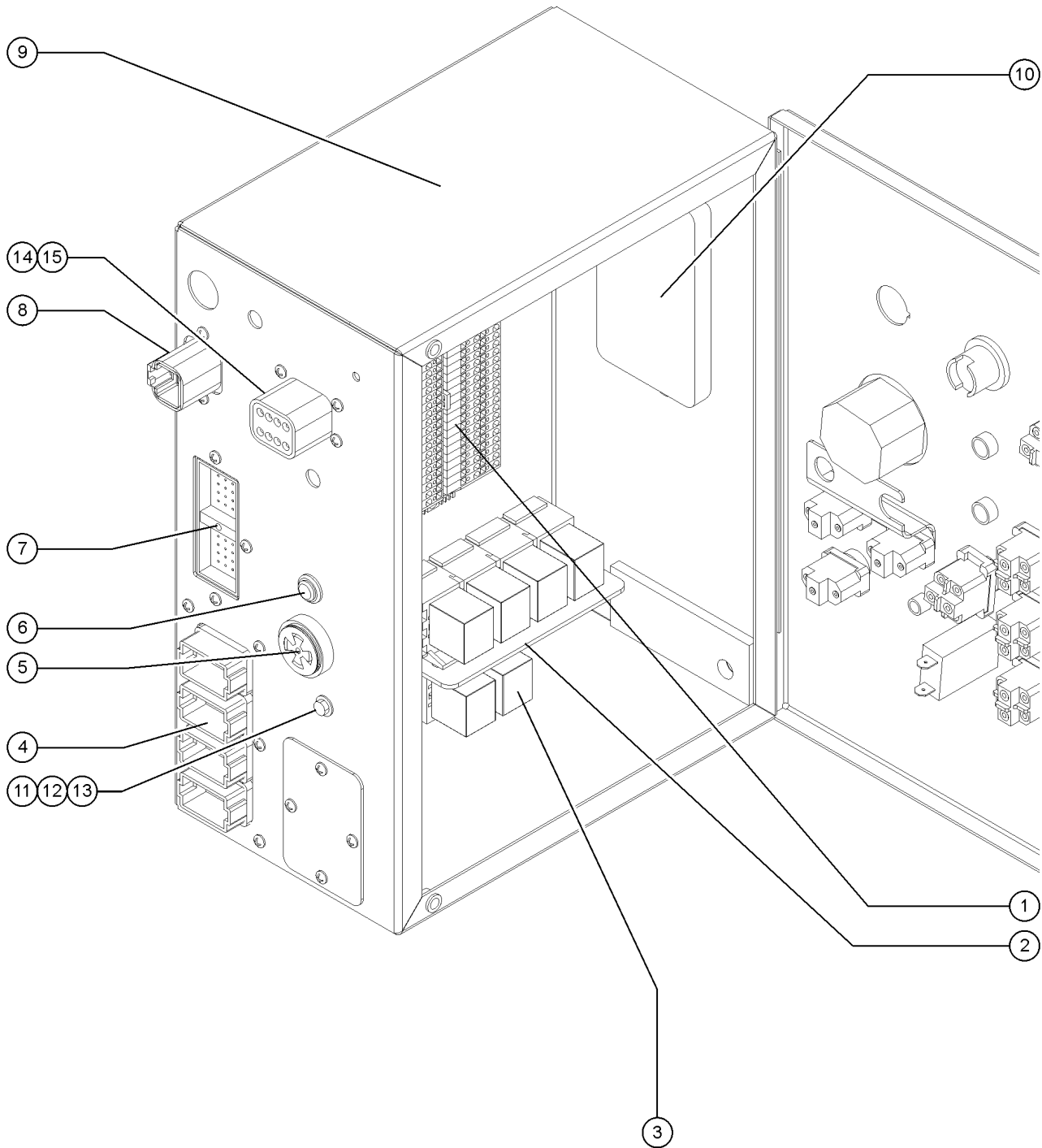

306.1 Ground Control Box - View 2

Item	Part No.	Description	Qty.	Item	Part No.	Description	Qty.
1A		ASSY,TERMINAL RAIL,Z45DC/BE.....1 <i>(94639 no longer available, use kit 217046) to SN Z452513A-47173</i>		7	73754GT	CONN,RECEP 40 WAY,W/FLANGE.....1	
--	216793GT	TERMINAL BLOCK END PLATE.....1 <i>(for 94639) to SN Z452513A-47173</i>		8	73717GT	CONN,RECEP 4 WAY,12-14GA FL***1	
--	56994GT	DIN RAIL,11.25" <i>(for 94639) to SN Z452513A-47173</i>		--	60526GT	LOCK,RECEP 4 WAY,12-14GA	
--	74911GT	TERMINAL BLOCK, WIELAND*** <i>(for 94639) to SN Z452513A-47173</i>		9	101844GT	GROUND CONTROL BOX ASSY W/DEC*.....1	
--	74913GT	END STOP, DIN RAIL,SCREW CLAMP <i>(for 94639) to SN Z452513A-47173</i>		--	30997GT	CORROSION INHIBITOR,FOAM	
--	74917GT	JUMPER COMB, 2-WAY,WIELAND <i>(for 94639) to SN Z452513A-47173</i>		--	88637GT	GASKET,GROUND CONTROL BOX***	
1B	217046GT	KIT, TERMINAL BLOCK <i>(replaces PN 94639) to SN Z452513A-47173</i>		10	128045GT	MODULE,LOAD SENSE 2007.....1	
--	216791GT	TERMINAL BLOCK,WIELAND <i>(for kit 217046) to SN Z452513A-47173</i>		--	54365GT	SCREW,PHIL,PHM,10-32 X .5,SSTL	
--	216793GT	TERMINAL BLOCK END PLATE <i>(for kit 217046) to SN Z452513A-47173</i>		--	6178GT	NUT,NYLOCK,10-32	
1C	218083GT	ASSY,TERMINAL RAIL,Z45DC/BE <i>from SN Z452513A-47174</i>		11	6888GT	SCREW,HHC,1/4-20 X 1	
--	216791GT	TERMINAL BLOCK,WIELAND.....28 <i>from SN Z452513A-47174</i>		12	6638GT	WASHER,FLAT,USS,1/4"Y	
--	216793GT	TERMINAL BLOCK END PLATE <i>from SN Z452513A-47174</i>		13	6091GT	NUT,NYLOCK,1/4-20	
--	56994GT	DIN RAIL,11.25" <i>from SN Z452513A-47174</i>		14A	1258768GT	CONN,PLUG 8WAY,BLOCKED GROMMET <i>models without telematics</i>	
--	74913GT	END STOP, DIN RAIL,SCREW CLAMP.....2 <i>from SN Z452513A-47174</i>		14B	119060GT	CONN PLUG 8 WAY ENDCAP DT <i>models with telematics</i>	
--	74917GT	JUMPER COMB, 2-WAY,WIELAND <i>from SN Z452513A-47174</i>		14C	60447GT	LOCK,RECEP 8 WAY,14-18GA <i>models with telematics</i>	
2A	54534GT	ANGLE,RELAY MNT,W/NUTSERTS,PNT.....1 <i>includes nutserts, to SN Z452515A-53270</i>		14D	60433GT	LOCK,PLUG 8 WAY, 14-18GA <i>not shown, models with telematics</i>	
--	23404GT	NUTSERT,1/4-20,STEEL CAD PLTD.....2		14E	60757GT	PLUG,SEAL,12-18 GA <i>not shown, models with telematics</i>	
2B	T106699GT	BRACKET,RELAY MOUNT W/INSERTS.....1 <i>includes nutserts, from SN Z452515A-53271</i>		15	87755GT	CONN,RECEP 8 WAY 14-18GA,FL <i>from SN Z452515A-53271</i>	
--	23404GT	NUTSERT,1/4-20,STEEL CAD PLTD.....2					
3	56302GT	RELAY,24VDC,40/30A,SEALED***6					
--	34053GT	ASSY,RELAY SOCKET, AUTO <i>components no longer available</i>					
4	73736GT	CONN,RECEP 48 WAY,4 X 12.....1					
--	54255GT	LOCK,RECEP 12 WAY, 14-18GA					
5	45462GT	ALARM,CHIME TONE 5-25VDC***1 <i>Does not include 72326 nut</i>					
--	72326GT	NUT - PLASTIC,RING FOR ALARMS					
6	218164GT	LIGHT,INDICATOR,RED 24V H-BRI <i>original light no longer available</i>					

307.1 Turntable Covers - View 1

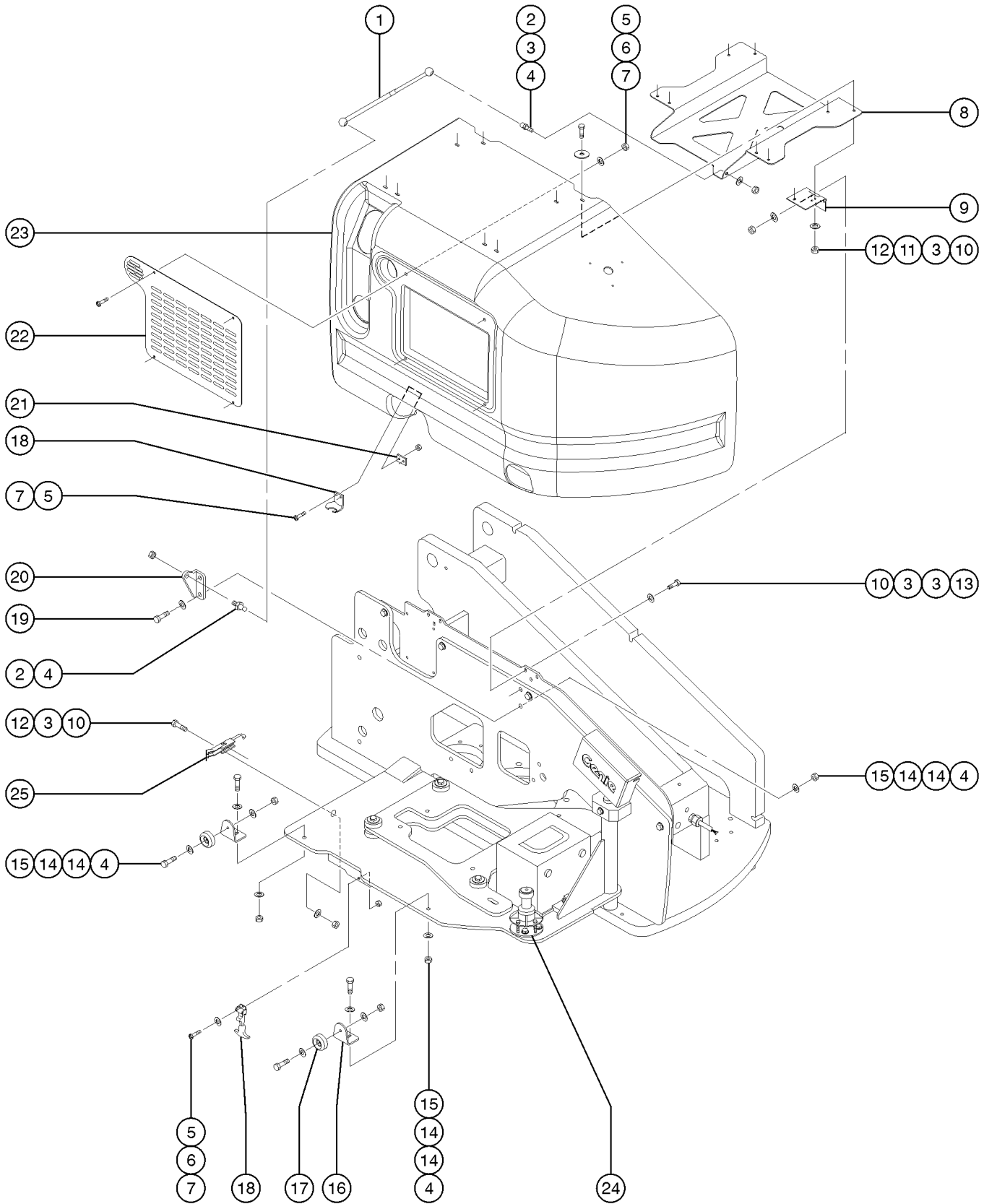

307.1 Turntable Covers - View 1

Item	Part No.	Description	Qty.	Item	Part No.	Description	Qty.
1	106069GT	STRUT,GAS,200 LB***.....	2	24A	6091GT	NUT,NYLOCK,1/4-20	
--	33555GT	BALL STUD**		24A	6638GT	WASHER,FLAT,USS,1/4"Y	
2	27114GT	BALL STUD,1/2" BALL,3/8-16X1.2		24A	6888GT	SCREW,HHC,1/4-20 X 1	
3	6638GT	WASHER,FLAT,USS,1/4"Y		25		Ref: Adjustable draw latch refer to 301.1	
4	4828GT	NUT,NYLOCK,3/8-16					
5	6178GT	NUT,NYLOCK,10-32					
6	6146GT	WASHER,FLAT,MS,#10,Y					
7	49816GT	SCREW,PHILLIPS,PHM,10-32 X .75					
8	50990-SGT	FORMING,ENG.COVER SUPPORT,PNTD.....	1				
9	75073GT	HINGE,.375X.120THK.,SLOTTED.....	2				
10	6091GT	NUT,NYLOCK,1/4-20					
11	12906GT	WASHER,FENDER,.25 X 1.25 X.062					
12	8915GT	SCREW,HHC,1/4-20 X 1.25					
13	6888GT	SCREW,HHC,1/4-20 X 1					
14	5397GT	WASHER,FLAT,USS,5/16",Y					
15	8516GT	SCREW, HCC, 3/8-16 X 1.50					
16	54363GT	BRACKET,RUBBER BUMPER,ENGCOVER.....	2				
17	50974GT	BUMPER,RUBBER,COVERS.....	2				
18	45363GT	LATCH,FLEXIBLE DRAW W/O KEEPER.....	2				
18	75076GT	KEEPER,LATCH (45363).....	2				
19	13918GT	SCREW,HHC,3/8-16 X 1.75,GRD.8.....	1				
20	107594GT	FORMING,GAS STRUT MOUNT,PNTD**.....	1				
21	50790GT	PLATE,COVER LATCH BACKING.....	2				
22	60126-SGT	COVER PLATE,AIR INTAKE,GRAY.....	1				
23A	101860GT	COVER ASSY W/WRD DECALS,LH BI... <i>Bi-Energy</i>	1				
23B	101863GT	COVER ASSY W/SYM DECLS,LH DC <i>Bi-Energy</i>					
23C	101861GT	COVER ASSY W/WRD DECALS,LH DC DC					
23D	101864GT	COVER ASSY W/SYM DECALS,LH DC (to serial number Z452508A-35522)					
23E	T115412GT	COVER ASSY W/SYM DECALS,LH DC (from serial number Z452508A-35523)					
23F	60110GT	COVER,TURNTABLE,LH,BI-ENERGY decals not included, refer to section one for decals					
23G	50784GT	COVER,TURNTABLE,LH,DC/BE decals not included, refer to section one for decals					
24	110382GT	LEVEL SENSOR,LS60,YL,2.5X4.5 CE models					
24	94077GT	SENSOR,LEVEL,4.5 DEG..... ANSI/CSA/Australia models	1				

308.1 Turntable Covers - View 2

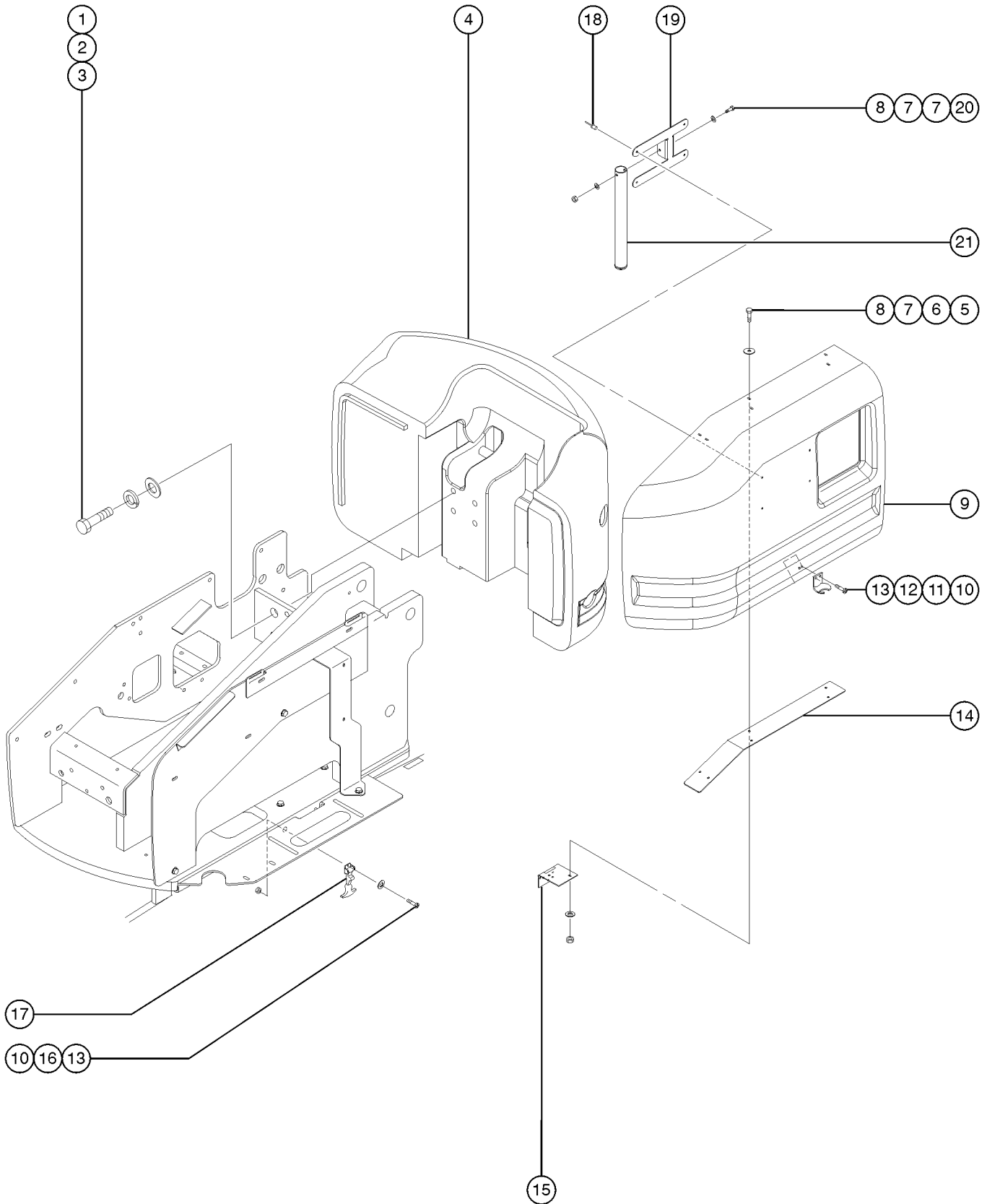

308.1 Turntable Covers - View 2

Item	Part No.	Description	Qty.
1	42078GT	SCREW,HHC,1-8 X 3 GRD.5.....	4
2	29605GT	WASHER,LOCK,1"	
3	38859GT	WASHER,FLAT,USS,1",Y	
4B	60145GT	COUNTERWEIGHT,CAST,DC/BI,W/JIB..1 (Z-45/25J)	1
5	6888GT	SCREW,HHC,1/4-20 X 1	
6	12906GT	WASHER,FENDER,.25 X 1.25 X.062	
7	6638GT	WASHER,FLAT,USS,1/4"Y	
8	6091GT	NUT,NYLOCK,1/4-20	
9A	101858GT	COVER ASSY W/WRD DECALS,RH BI..... <i>Bi-Energy</i>	1
--	77034PGT	FORMING,CLEVIS PROP ROD,DC/BI	
--	77524GT	TUBE,PROP ROD,18.63",W/CAP	
9B	101859GT	COVER ASSY W/WRD DECALS,RH DC DC	
9C	101862GT	COVER ASSY W/SYM DECLS,RH BIDC <i>Bi-Energy and DC</i>	
9D	77032GT	COVER,TANK SIDE,DC/BI.....	1
10	49816GT	SCREW,PHILLIPS,PHM,10-32 X .75	
11	75076GT	KEEPER,LATCH (45363).....	2
12	50790GT	PLATE,COVER LATCH BACKING.....	2
13	6178GT	NUT,NYLOCK,10-32	
14	139417PGT	DOUBLER,BENT,COVER,DC/BI,RH.....	1
15	75073GT	HINGE,.375X.120THK.,SLOTTED.....	2
16	6146GT	WASHER,FLAT,MS,#10,Y	
17	45363GT	LATCH,FLEXIBLE DRAW W/O KEEPER.....	2
18	7265GT	RIVET,STEEL,P, .25 X .375.....	4
19	77034PGT	FORMING,CLEVIS PROP ROD,DC/BI....	1
20	8179GT	SCREW,HHC,1/4-20 X 2.25	
21	54455PGT	TUBE,PROP ROD,12.25"LG,DC/BI.....	1

309.1 Wire Harness Diagram

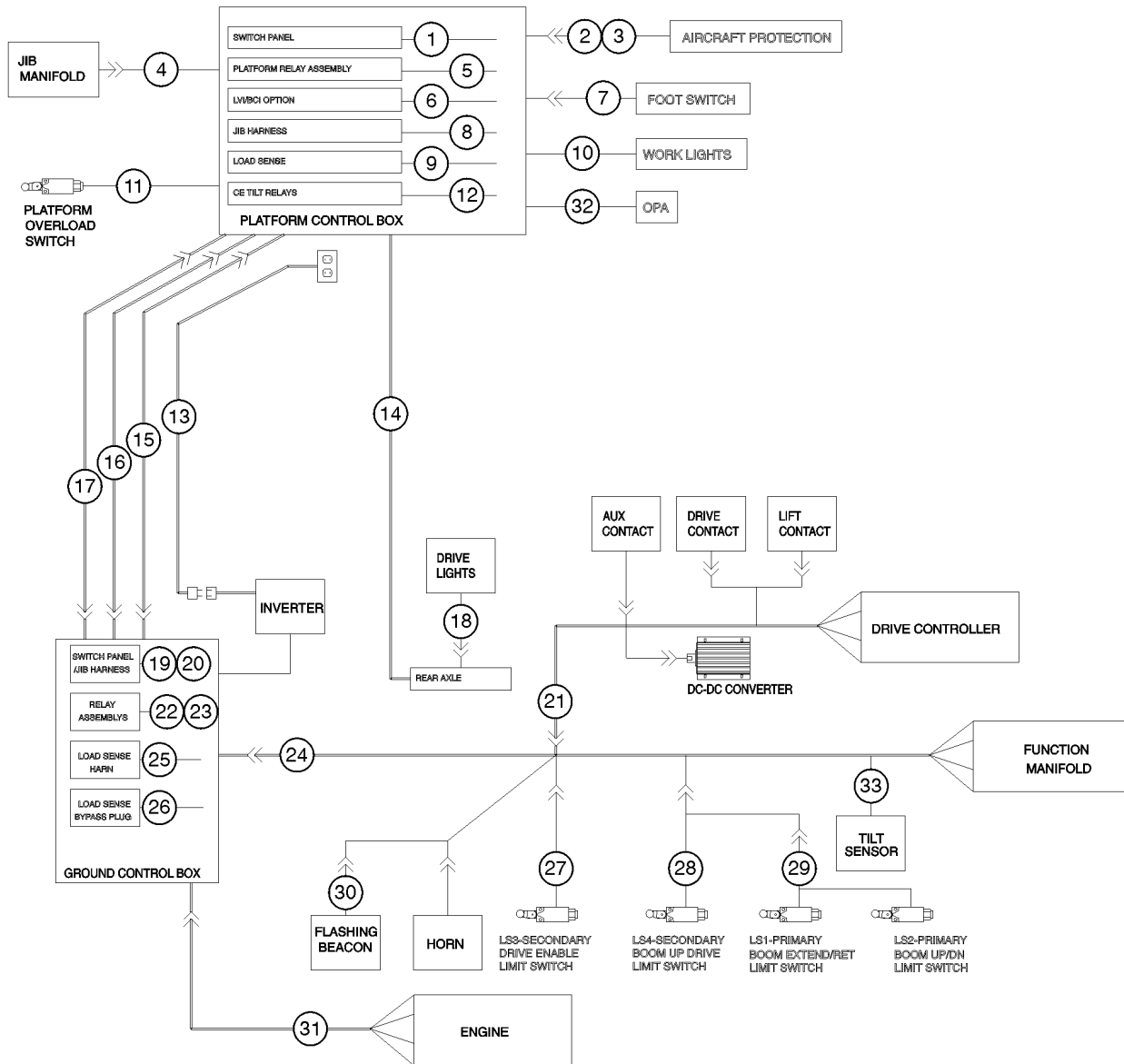

309.1 Wire Harness Diagram

Item	Part No.	Description	Qty.	Item	Part No.	Description	Qty.
B	1264822GT	KIT, TRC RETROFIT, STNDRD <i>Telematics (includes 1264834)</i>		22	1259639GT	HARN,GBOX Z45DC/BE RELAY ASSY.....1	1
--	1264834GT	INSTRN, TRC RETROFIT, STNDRD		23A	1261899GT	HARNESS,Z45DC,TELEMATICS READY.....1	1
1	1262220GT	HARNESS, PBOX, Z45DC/BE.....1	1			<i>DC models</i>	
2	1266606GT	HARN, AC PROTECTION BYPASS.....1 <i>option, aircraft protection</i>	1	23B	1261900GT	HARNESS,Z45BE,TELEMATICS READY.....1	1
3	110657GT	HARNESS,PROX.KILL,24V.....1 <i>option, aircraft protection</i>	1			<i>Bi-Energy models</i>	
--	27391GT	PROXIMITY SENSOR***		24	128812GT	HARN FUNCTION MAN Z45DC/BE.....1	1
--	78098GT	RELAY,24VDC,40/30A,SLD W/BRKT*		25	1260173GT	HARNESS ASSY, RELAY, CE.....1 <i>CE models</i>	1
4	101080GT	HARNESS,JIB SELECT MANIFOLD.....1	1	26	88832GT	HARNESS,PLUG,NON-LOAD WEIGHING.....1	1
5	1261221GT	HARN,RELAY Z45DC/BE,PBOX.....1	1	27	128816GT	HARN LIMIT SW DE Z45DC/BE.....1	1
6	128941GT	HARNESS LVI/BCI ENGAGE II.....1	1	28	88724GT	HARNESS,LS,PRIM/EXT/SEC.....1	1
7		REF: Foot Switch.....1 <i>refer to 601.1</i>	1	29	88725GT	HARNESS,LS,PRIM/EXT.....1	1
8A	88713GT	HARNESS,PLATFORM,Z45DC,BI,JIB.....1 <i>to SN Z45D-1654</i>	1	30		REF: Flashing Beacon.....1 <i>refer to 901.1</i>	1
8B	1284282GT	HARNESS,PLAT,Z45DC/BI,JIB.....1 <i>from SN Z45D-1655</i>	1	31	139368GT	HARNESS,ENGINE,Z45BE.....1 <i>Bi-Energy models</i>	1
--	56445GT	DIODE,6 AMP 200 PIV,REEL		32A	1255858GT	HARN,PBOX,OPA,HW,24V.....1 <i>option</i>	1
9	216769GT	HARNESS,JUMPER,LOAD SENSE.....1	1	32B	1255030GT	PLUG,BLANKING.....1	1
10	823774GT	HARNESS, 48V DRIVE LIGHTS.....1 <i>option</i>	1	33	1261845GT	HARNESS,TILT 24V,CSA PROD.....1	1
11	121848GT	ASSY,LS,LOAD SENSE,38.5 IN.....1	1				
12	1262223GT	HARNESS,RELAY,PBOX,Z45DC,CE.....1 <i>CE models</i>	1				
13B	30794GT	WIRE,12/3 SJEOW,BK-WH-GR/YL.....732-inches <i>jib models</i>					
14	823774GT	HARNESS, 48V DRIVE LIGHTS.....1 <i>option</i>	1				
15B	88723-69700GT	HARNESS,PLAT,Z45DC/BI,JIB.....1 <i>jib models</i>	1				
16B	88722-70700GT	HARNESS,18/19,BOOM CABLE #2.....1 <i>jib models</i>	1				
17B	88721-70700GT	HARNESS,18/19 BOOM CABLE #1.....1 <i>jib models</i>	1				
18	823774GT	HARNESS, 48V DRIVE LIGHTS.....1 <i>option</i>	1				
19A	1259323GT	HARNESS,BASE BOX Z45BI-ENERGY.....1 <i>models</i>	1				
19B	1259322GT	HARNESS,BASE BOX Z45DC <i>models</i>					
20	1262512GT	HARNESS, JIB, BASE BOX.....1 <i>jib models</i>	1				
21A	822777GT	HARNESS, DRIVE CHASSIS, Z45DC.....1 <i>DC models</i>	1				
21B	822778GT	HARNESS, DRIVE CHASSIS, Z45BE.....1 <i>Bi-Energy models</i>	1				

401.1 Boom Pins and Bearings

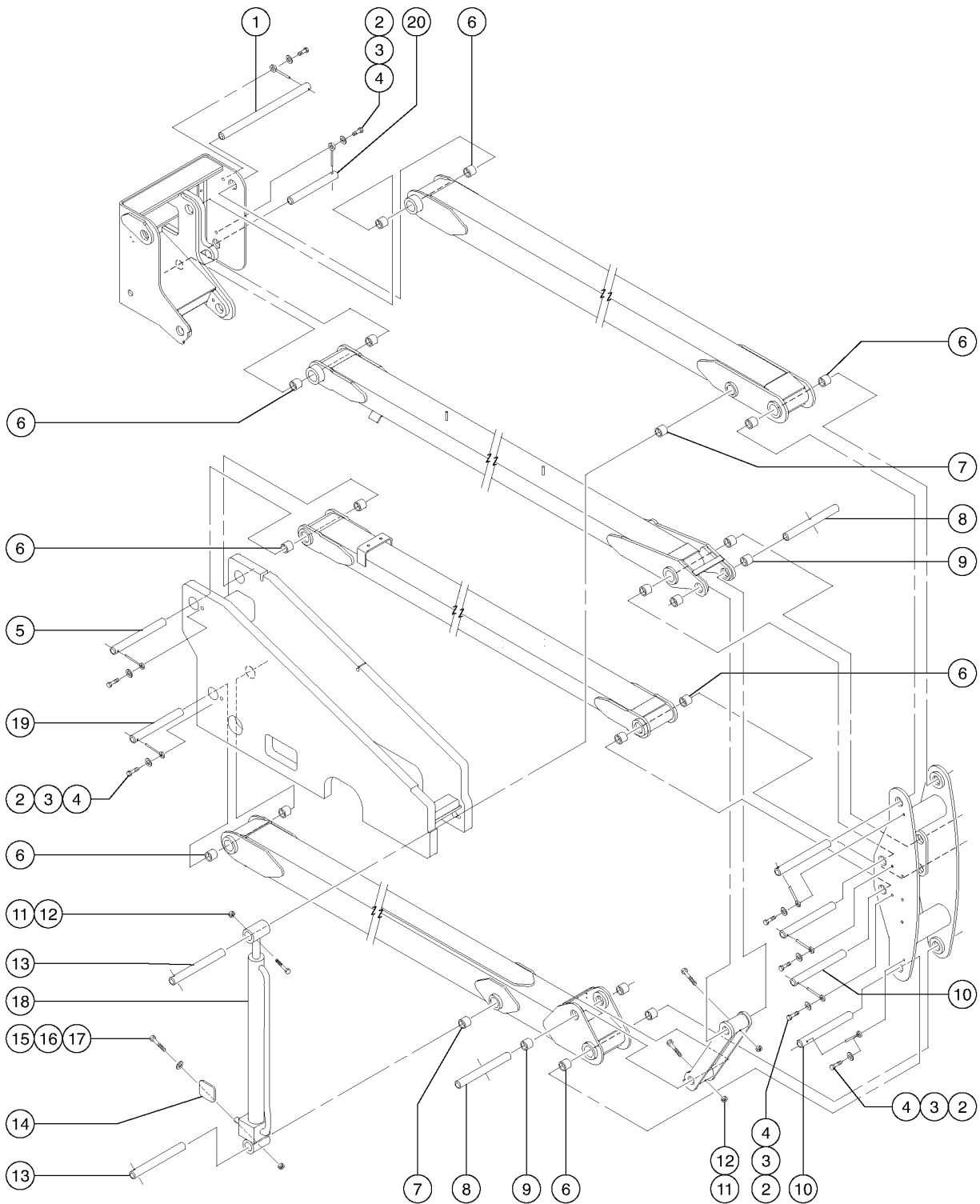

401.1 Boom Pins and Bearings

Item	Part No.	Description	Qty.
1	88676GT	PIN,2.00DIAX24.00LG,CHAMFER***.....1	
2	8177GT	SCREW,HHC,1/2-13 X 1.5	
3	6033GT	WASHER,LOCK,0.5"	
4	1256267GT	ROD END,.5 X 3.75,ZAG	
5	107859GT	PIN,2.00DIAX12.88LG,CHAMFER***.....1 (replaced 107589)	
6	18720GT	BEARING,2.0IDX2.25ODX1.50L.....16	
7	45071GT	BEARING,1.5IDX1.75ODX1.5L.....2	
8	107727GT	PIN,1.50DIAX7.50LG,1HOLE***.....2	
9A	54156GT	BEARING,FL,1.5IDX1.75ODX1.10LG.....4	
9B	1258159GT	KIT, BOOM BEARING.....1 <i>jib models from SN Z452511B-1727 to Z452513B-2766</i>	
10	107588GT	PIN,2.00DIAX10.88LG,CHAMFER.....4	
11	4828GT	NUT,NYLOCK,3/8-16	
12	14033GT	SCREW,HHC,3/8-16 X 2.75	
13	50455GT	PIN,1.50DIAX13.88LG,2HOLE.....2	
18	88203GT	CYLINDER,ELEVATE,Z45/25***.....2	
--	77303GT	VALVE, CNTRBAL 3500 PSI, ATM VEN	
--	77521GT	SEAL KIT,ELEVATE (88203)	
19	107590GT	PIN,2.00DIAX12.88LG,CHAMFER***.....1	
20	107859GT	PIN,2.00DIAX12.88LG,CHAMFER***.....1 (replaced 107589)	

402.1 Secondary Linkage

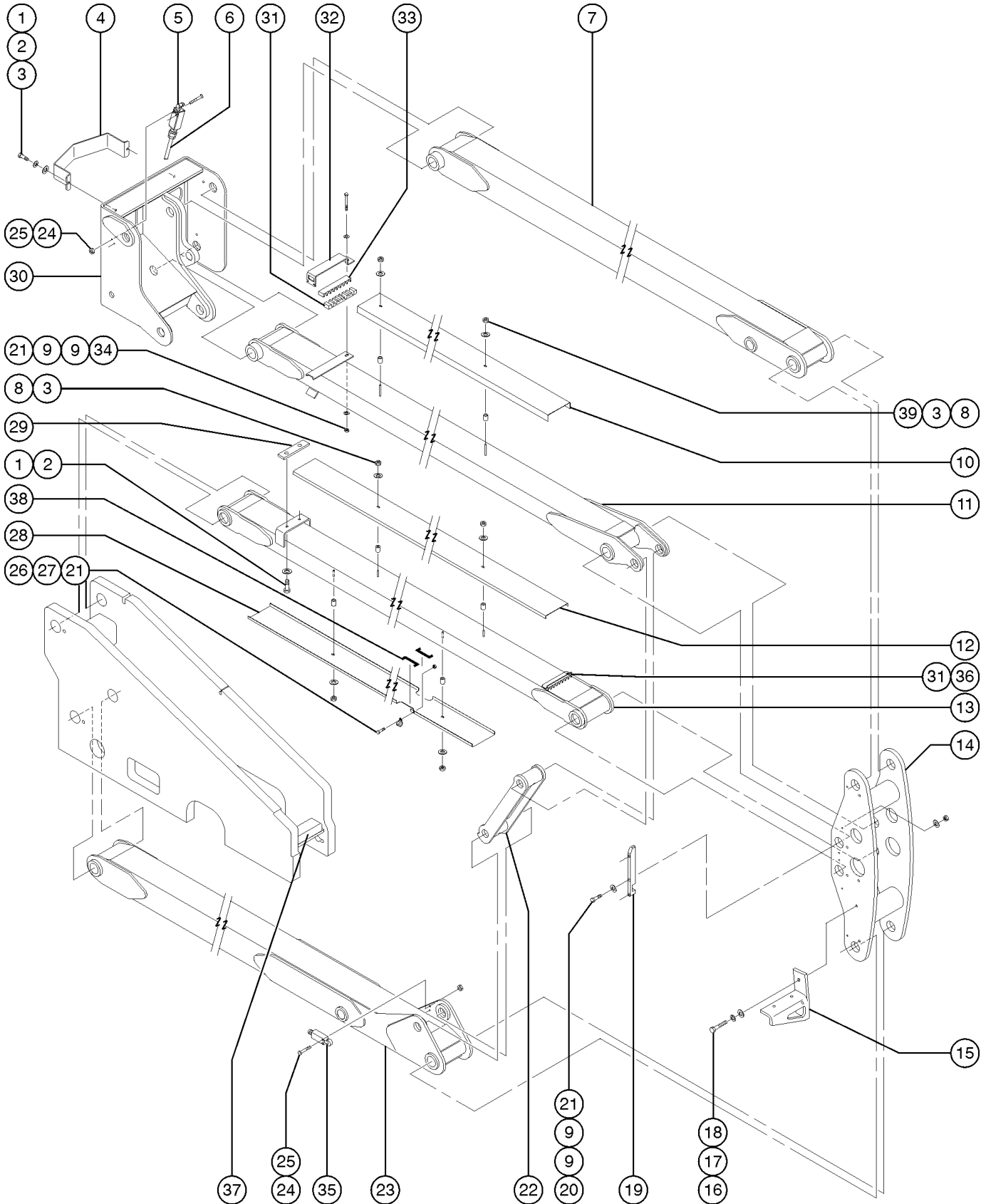

402.1 Secondary Linkage

Item	Part No.	Description	Qty.	Item	Part No.	Description	Qty.
1	6175GT	SCREW,HHC,3/8-16 X 1		32	94531PGT	BRACKET,HOSE CLAMP PAINTED***.....1	
2	6021GT	WASHER,LOCK,.375		33	94530GT	CLAMPING BLOCK,CABLE.....1	
3	6097GT	WASHER,FLAT,USS,3/8",Y		34	6888GT	SCREW,HHC,1/4-20 X 1	
4	237688GT	COVER, UPPER PIVOT.....1		35	88356-11205GT	SWITCH,LIMIT,W/RLLR ARM NO/NC.....1	
5	88356-11163GT	SWITCH,LIMIT,W/RLLR ARM,NO/NC*...1		--	89756GT	NECK/HEAD-LIMIT SWITCH (88356)	
--	106427GT	LS ROT.HEAD W/O LEVER (ZCE01)		--	97128GT	ROLLER ARM,LIMIT SWITCH***	
--	97128GT	ROLLER ARM,LIMIT SWITCH***		36	70685PGT	FORMING, HOSE CLAMP, PAINTED	
6	43960GT	WIRE CABLE,16/4 CON.TPE JKT.....360-inches		37	56849GT	PAD,REST,1"THICK,W/STUDS*.....1	
7	110305GT	UPPER SECONDARY ARM ASSY-Z45**.....1		38	1697-400GT	TRIMLOCK,BLACK,3/16 X 4 INCHES.....2	
8	7713GT	NUT, LP NYLOCK, 3/8-16		39	42941-75GT	HOSE,3/8",FUEL,30R7	
9	6638GT	WASHER,FLAT,USS,1/4"Y					
10	88370PGT	HOSE COVER,UPPER ARM,PAINTED					
11	110306GT	UPPER LEVEL ARM ASSY,SERV***.....1					
12	50517-SGT	HOSE COVER,LOWER LEVEL,TOP,PAI.....1					
13	110307GT	LOWER LEVEL ARM ASSY***.....1					
14	110310GT	MIDPIVOT ASSY Z45IC***.....1 <i>USA/Canada/Australian</i>					
--	106972GT	WELDMENT,MID PIVOT,MACHINED*** <i>Europe/Asia/ South America</i>					
15		Ref., WEAR PAD <i>refer to 504.1</i>					
15	50952-SGT	BOOM REST WELDMENT.....1 <i>Z-45/25J</i>					
16B	8177GT	SCREW,HHC,1/2-13 X 1.5 <i>Z-45/25J</i>					
17	6033GT	WASHER,LOCK,0.5" <i>Z-45/25J</i>					
18	6095GT	WASHER,FLAT,USS,1/2",Y <i>Z-45/25J</i>					
19	107881GT	WEAR PAD,MID PIVOT***.....1 <i>Z-45/25J</i>					
20	6637GT	SCREW,HHC,1/4-20 X 1.75					
21	6091GT	NUT,NYLOCK,1/4-20					
22	50479-SGT	CONNECTING LINK, Z45/25.....1					
23	110308GT	LOWER SECONDARY ARM ASSY***.....1					
24	49775GT	SCREW,PHILLIPS,PHM,10-32X 1.75					
25	6178GT	NUT,NYLOCK,10-32					
26	8914GT	SCREW,HHC,1/4-20 X .625					
27	6833GT	CLAMP,0.50,#8 X 1/4,RUB CUSH					
28	50548PGT	HOSE COVER,LOWER LEVEL,BOT,PAI.....1					
29	49772GT	WEAR PAD,6 X 1.5 X .50,W/INSERT.....1					
30		Ref. Upper Pivot Assembly(refer to 503.1)					
31	94529GT	CLAMPING BLOCK,HOSE***.....2					

403.1 Upper Pivot

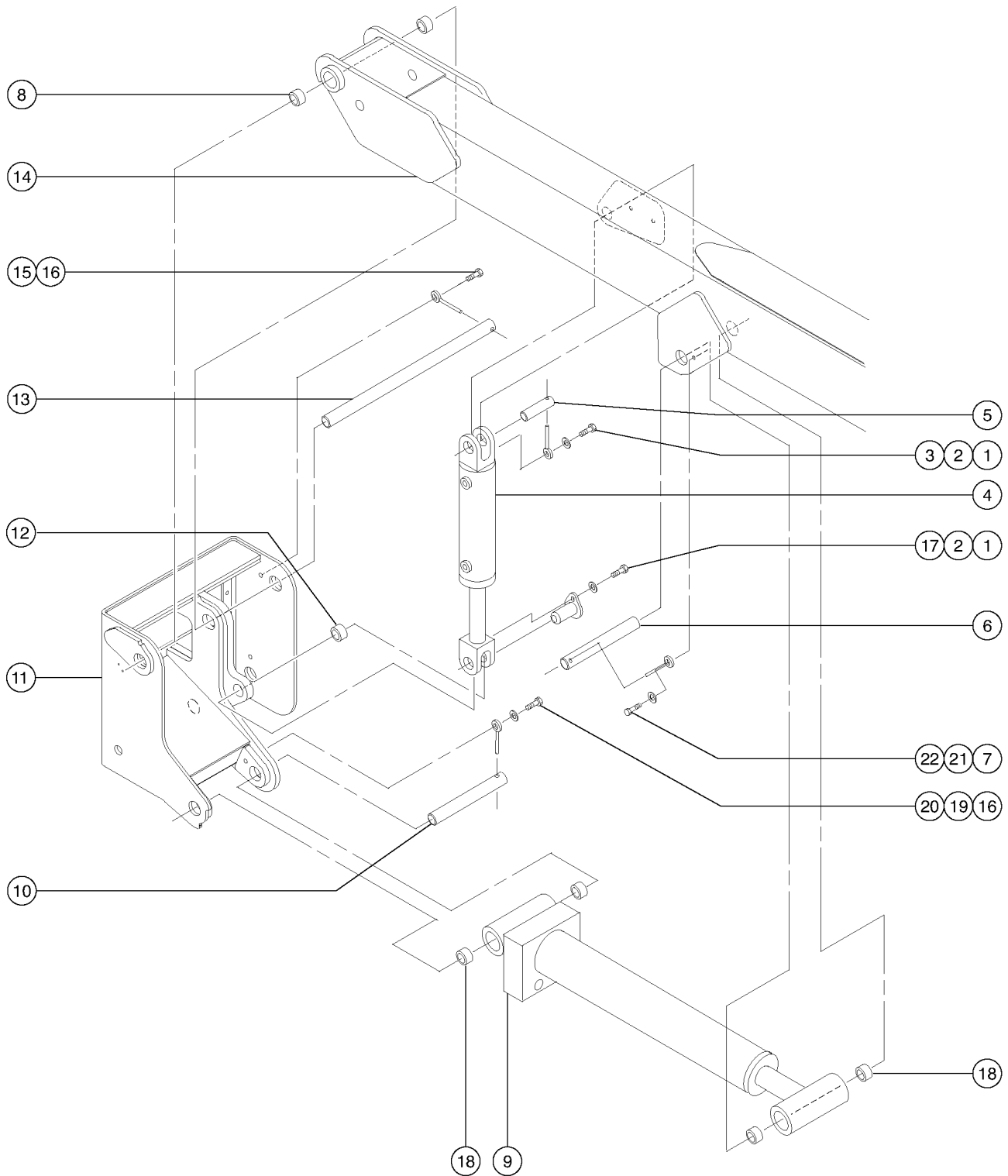

Item	Part No.	Description	Qty.
1	6175GT	SCREW,HHC,3/8-16 X 1	
2	6021GT	WASHER,LOCK,.375	
3	1255452GT	ROD END,.375 X 2.25,ZAG	
4	77362GT	CYLINDER,MASTER,Z45***.....1	
--	77364GT	SEAL KIT,MASTER & SLAVE CYL	
5	34276GT	PIN,1.25DIAX3.37LG,1HOLE.....1	
6	50542GT	PIN,1.75DIAX9.25LG,1HOLE.....1	
7	825019GT	ROD END,.375X3.69,ZAG	
8	18720GT	BEARING,2.0IDX2.25ODX1.50L.....2	
9B	1263057GT	CYLINDER,PRIM LIFT JIB,Z45.....1 <i>includes item 18</i>	
--	77014GT	VALVE,COUNTERBALANCE,3800 PSI <i>for 77188, 1263057 (from SN 19887 to SN 40637 and from SN 42132) (identify part number on cylinder before ordering)</i>	
--	77189GT	SEAL KIT,CYL,Z45 (77187&77188) <i>for 77188, 1263057 (identify part number on cylinder before ordering)</i>	
9C	50480GT	VALVE,COUNTERBALANCE,3800 PSI* <i>for 147260 (from SN 40638 to SN 42131) (identify part number on cylinder before ordering)</i>	
9D	147284GT	SEAL KIT,147260*** <i>for 147260 (from SN 40638 to SN 42131) (identify part number on cylinder before ordering)</i>	
10	70534GT	PIN,1.75DIAX11.88LG,CHAMFER.....1	
11	110309GT	UPPER PIVOT W/BEARING-Z45/25**	
--	55753GT	BUMPER, PLASTIC, 1.25 O.D.	
12	30370GT	BEARING,1.25IDX1.5ODX1.00L.....1	
13	88676GT	PIN,2.00DIAX24.00LG,CHAMFER***.....1	
14		Ref. Primary Boom Tube Assembly (refer to 504.1)	
15	10597GT	SCREW,HHC,1/2-13 X 1.25 GR5	
16	1256267GT	ROD END,.5 X 3.75,ZAG	
17	120282GT	PIN,1.25 DIA X 3.19 LG, PLATE.....1	
18	1262633GT	BEARING,POLYGON,BM5120.....4	
19	8177GT	SCREW,HHC,1/2-13 X 1.5	
20	6033GT	WASHER,LOCK,0.5"	
21	8516GT	SCREW, HCC, 3/8-16 X 1.50	
22	4828GT	NUT,NYLOCK,3/8-16	

404.1 Primary and Extension Booms

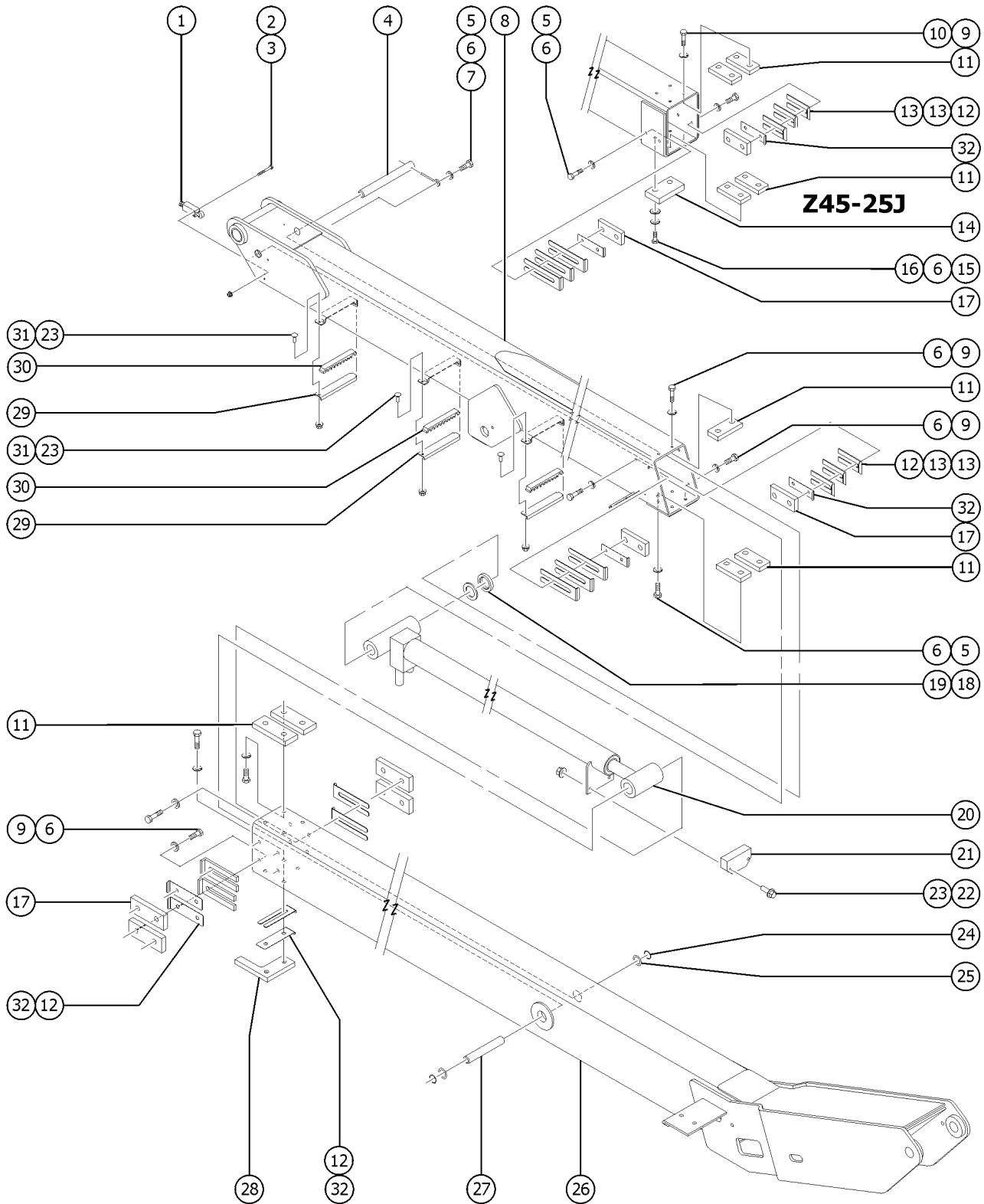

404.1 Primary and Extension Booms

Item	Part No.	Description	Qty.	Item	Part No.	Description	Qty.
--	150103GT	WIRE LOOM,1.25"NYLON,HIGH TEMP.....129-inches		--	77410GT	VALVE,COUNTERBALNCE,1500 PSI**	
1	88366-11205GT	SWITCH,LIMIT,W/RLLR ARM NO/NC.....1		20B	54569GT	CYLINDER,EXTEND,Z45J***.....1 Z-45/25J	
--	97128GT	ROLLER ARM,LIMIT SWITCH***		--	54063GT	VALVE,CB.CBBC-LHN@1000***	
2A	1256922GT	SCREW,PHPM,10-32X2.25,ZAG.....2 Z-45/25		--	65790GT	SEAL KIT CYL.Z45(54569)	
2B	1265481GT	SCREW,PHPM,10-32X2,ZAG.....2 Z-45/25J		--	77410GT	VALVE,COUNTERBALNCE,1500 PSI**	
3	1264261GT	NUT,SERRATED,10-32,ZAG.....2		21	50698GT	WEAR PAD,EXTENSION CYLINDER.....1	
4	50584GT	PIN,1.25DIAX9.38LG,THREADED.....1		22A	824082GT	SCREW,HHF,1/4-20X1.75,8,ZAG.....2 Z-45/25	
5A	824068GT	SCREW,HHC,3/8-16X1.25,8,ZAG.....5 Z-45/25		22B	824063GT	SCREW,HHC,1/4-20X1.75,8,ZAG.....2 Z-45/25J	
5B	824068GT	SCREW,HHC,3/8-16X1.25,8,ZAG.....11 Z-45/25J		23	824027GT	NUT,TL FLG,1/4-20,G,ZAG.....5	
6A	824110GT	WASHER,LOCK,3/8,ZAG.....29 Z-45/25		24	824164GT	SNAP RING,EXTERNAL,1.25,ZAG.....2	
6B	824110GT	WASHER,LOCK,3/8,ZAG.....27 Z-45/25J		25	824151GT	WASHER,SHIM,1.270X2.130X.062,Z	
7	825019GT	ROD END,.375X3.69,ZAG.....1		26A	128605GT	WELDMENT, EXT. BOOM,Z45 NJ.....1 Z-45/25	
8A	128603GT	WELDMENT,PRIMARY BOOM,Z45NJ....1 Z-45/25		26B	128304GT	WELDMENT,EXT. BOOM,Z45 JIB.....1 Z-45/25J	
8B	128301GT	WELDMENT,PRIMARY BOOM,Z45 JIB.....1 Z-45/25J		27	50546GT	PIN,1.25DIAX6.36LG,2RING.....1	
9A	1256109GT	SCREW,HHC,3/8-16X.75,8,ZAG.....24 Z-45/25		28	50552GT	WEAR PAD,EXTENSION BOOM.....1	
9B	1256109GT	SCREW,HHC,3/8-16X.75,8,ZAG.....18 Z-45/25J		29	128995GT	FORMING, HOSE CLAMP RETAINER...3	
10	824113GT	WASHER,FLAT,USS,1/4,ZAG.....4 Z-45/25J only		30	128601GT	CLAMP, PRI, HOSE/CABLE, Z45/51.....3	
11A	34125GT	WEAR PAD,5 X 1.5 X .75 W/NUTS.....5 Z-45/25		31A	824124GT	BOLT,CARRIAGE,1/4-20X.75,5,ZAG.....3 Z-45/25	
11B	34125GT	WEAR PAD,5 X 1.5 X .75 W/NUTS.....6 Z-45/25J		31B	1256127GT	BOLT,CARRIAGE,1/4-20X1.5,ZAG.....3 Z-45/25J	
12	29080GT	SHIM,WEAR PAD,5X 1.5 16GA.....9		32	1287821GT	SHIM,WEAR PAD,5X 1.5,14GA,HOLE...5	
13	42502GT	SHIM,SIDE PAD 22GA.....8					
14	54157GT	WEAR PAD,PRIMARY BOOM,JIB.....1 Z-45/25J only					
15	1256847GT	SCREW,HHC,3/8-16X1.75,8,ZAG.....2 Z-45/25J only					
16	825358GT	WASHER,FLAT,5/16,USS,ZAG.....2 Z-45/25J only					
17	30138GT	WEAR PAD,5 X 1.5 X .625 W/NUTS.....8					
18	77375GT	SPACER,NYLON,2.01 X 1.28 X.135.....1					
19	77376GT	SPACER,NYLON,2.00 X 1.33 X.310.....1					
20A	54570GT	CYLINDER,EXTEND,Z45 NON JIB.....1 Z-45/25					
--	54063GT	VALVE,CB.CBBC-LHN@1000***					
--	65788GT	SEAL KIT CYL Z45 (54570)					

405.1 Cable Track

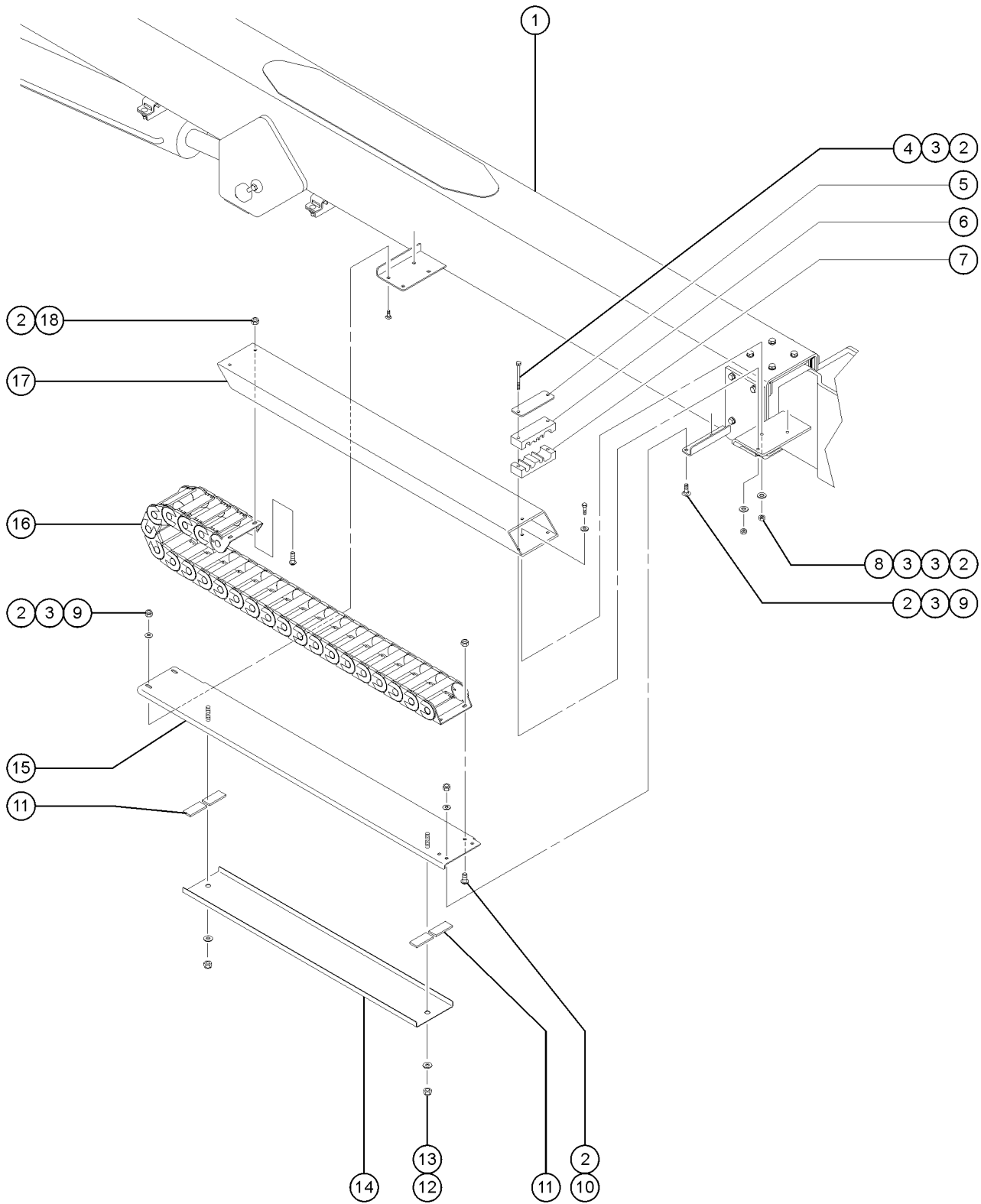

Item	Part No.	Description	Qty.
1		PRIMARY BOOM ASSY <i>refer to section 504</i>	
2	6091GT	NUT,NYLOCK,1/4-20	
3	6638GT	WASHER,FLAT,USS,1/4"Y	
4	12343GT	SCREW,HHC,1/4-20 X 3	
5	128862GT	BACKING PLATE, PULLTUBE.....1	
6	128310GT	CLAMP, JIB HOSE/CABLE, Z45/51.....1	
7	128311GT	CLAMP, JIB HOSE/CABLE, Z45/51.....1	
8	6888GT	SCREW,HHC,1/4-20 X 1	
9	6878GT	BOLT,CARRIAGE,1/4-20 X .75,G2	
10	12011GT	SCREW,BHHS,1/4-20 X .5,Y/ZINC	
11	54271GT	SPACER,HOSE CLAMP,RUBBER.....4	
12	4828GT	NUT,NYLOCK,3/8-16	
13	5397GT	WASHER,FLAT,USS,5/16",Y	
14B	128308GT	COVER,CABLETRACK TRAY,Z40/45.....1 <i>Z-45/25J</i>	
15B	139781GT	WELDMENT, CABLETRACK TRAY.....1 <i>Z-45/25J</i>	
16C	50452GT	CABLE TRACK,PLASTIC,35 LINK <i>Z-45/25J to SN Z452509A-38978</i>	
--	58919GT	REPAIR LINK,7 LINKS*** <i>for 50452</i>	
--	58920GT	REPAIR LINK END SET (42763)* <i>for 50452</i>	
--	58927GT	LINK,NYLATRAC KS6-5.4*** <i>for 50452</i>	
16D	139702GT	CABLE TRACK, NP400, 23 LINK.....1 <i>Z-45/25J from SN Z452509A-38979</i>	
--	111051GT	REPAIR LINK,7 LINKS NP400-7*** <i>for 139702</i>	
--	111052GT	REPAIR LINK,NP400-7*** <i>for 139702</i>	
--	111053GT	REPAIR END BRKT SET,NP400-7*** <i>for 139702</i>	
17B	128309GT	TUBE, CABLETRACK ARM, Z40/45.....1 <i>Z-45/25J</i>	
18	14297GT	SCREW,BHHS,1/4-20 X .75	

406.1 Non-Jib Platform Leveling and Rotation (Z-45/25)

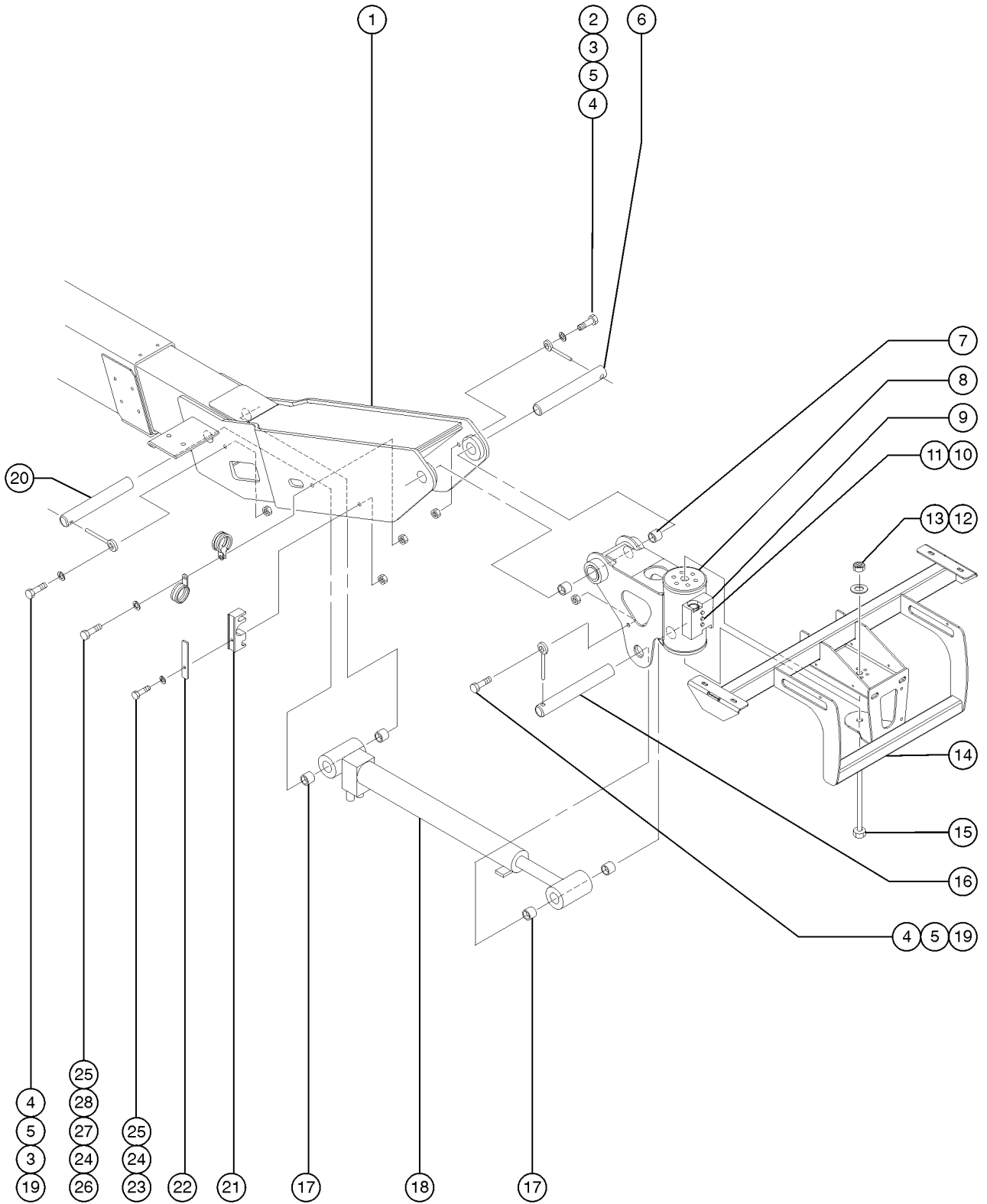

406.1 Non-Jib Platform Leveling and Rotation (Z-45/25)

Item	Part No.	Description	Qty.
--	150103GT	WIRE LOOM,1.25"NYLON,HIGH TEMP.....129-inches	
1		Ref. Primary Boom Tube Assembly (refer to 504.1)	
2	8516GT	SCREW, HCC, 3/8-16 X 1.50	
3	5397GT	WASHER,FLAT,USS,5/16",Y	
4	7713GT	NUT, LP NYLOCK, 3/8-16	
5	825019GT	ROD END,.375X3.69,ZAG	
6	50543GT	PIN,1.25DIAX8.88LG,1HOLE.....1	
7	30222GT	BEARING,FL,1.25IDX1.41ODX1.50L.....2	
8	233716GT	ROTATOR,PLAT,Z45.....1 <i>includes item 7; non-jib units</i>	
--	147369GT	SEAL AND BRG KIT,4.5K ROTATOR* <i>for 94402</i>	
--	233745GT	SEAL AND BRG KIT,4.5K ROTATOR <i>for 233716</i>	
9	73807GT	MANIFOLD,ROTATOR,CB***.....1	
10	6145GT	SCREW,HHC,1/4-20 X 1.5	
11	6356GT	WASHER,LOCK,.25	
12	77051GT	NUT,NYLOCK,3/4-10,GRD.8.....1	
13	33278GT	WASHER,FLAT,.75 HARDENED.....1	
14	54520-SGT	WELDMNT,PLATFRM SUPPORT,NJIB**.....1 <i>non-jib models</i>	
15	56925GT	SCREW,HHC,3/4-10 X 9.5 GR 8 YE.....1	
16	T108075GT	PIN,1.25DIAX5.25LG,1HOLE.....1	
17	25683GT	BEARING,POLYGON,20DU12.....4	
18	77363GT	CYLINDER,SLAVE,Z45***.....1 <i>includes item 17</i>	
--	54065GT	VALVE,COUNTERBALANCE,3500***	
--	77364GT	SEAL KIT,MASTER & SLAVE CYL	
19	6019GT	SCREW,HHC,3/8-16 X 1.25 GRD 5	
20	T107884GT	PIN,1.25DIAX7.00LG,1HOLE.....1	
21A	106526GT	CLAMP,HOSE ROUTE,2X#4,LOOM.....1 <i>(to SN 39070)</i>	
21B	139687GT	CLAMP, #4 HOSE, AIR AND LOOM <i>(from SN 39071) (shown)</i>	
22A	107595GT	BRACKET,HOSE CLAMP SUPPORT.....1 <i>(to SN 39070)</i>	
22B	139688GT	BRACKET, HOSE CLAMP SUPPORT <i>(from SN 39071) (shown)</i>	
23	36294GT	SCREW,HHC,1/4-20 X 2.75	
24	6638GT	WASHER,FLAT,USS,1/4"Y	
25	6091GT	NUT,NYLOCK,1/4-20	
26	6888GT	SCREW,HHC,1/4-20 X 1	
27	21619GT	CLAMP,1.50,#24 X 1/4,RUB CUSH	
28	21618GT	CLAMP,1.13,#18 X 1/4,RUB CUSH	

407.1 Jib Platform Leveling (Z-45/25J)

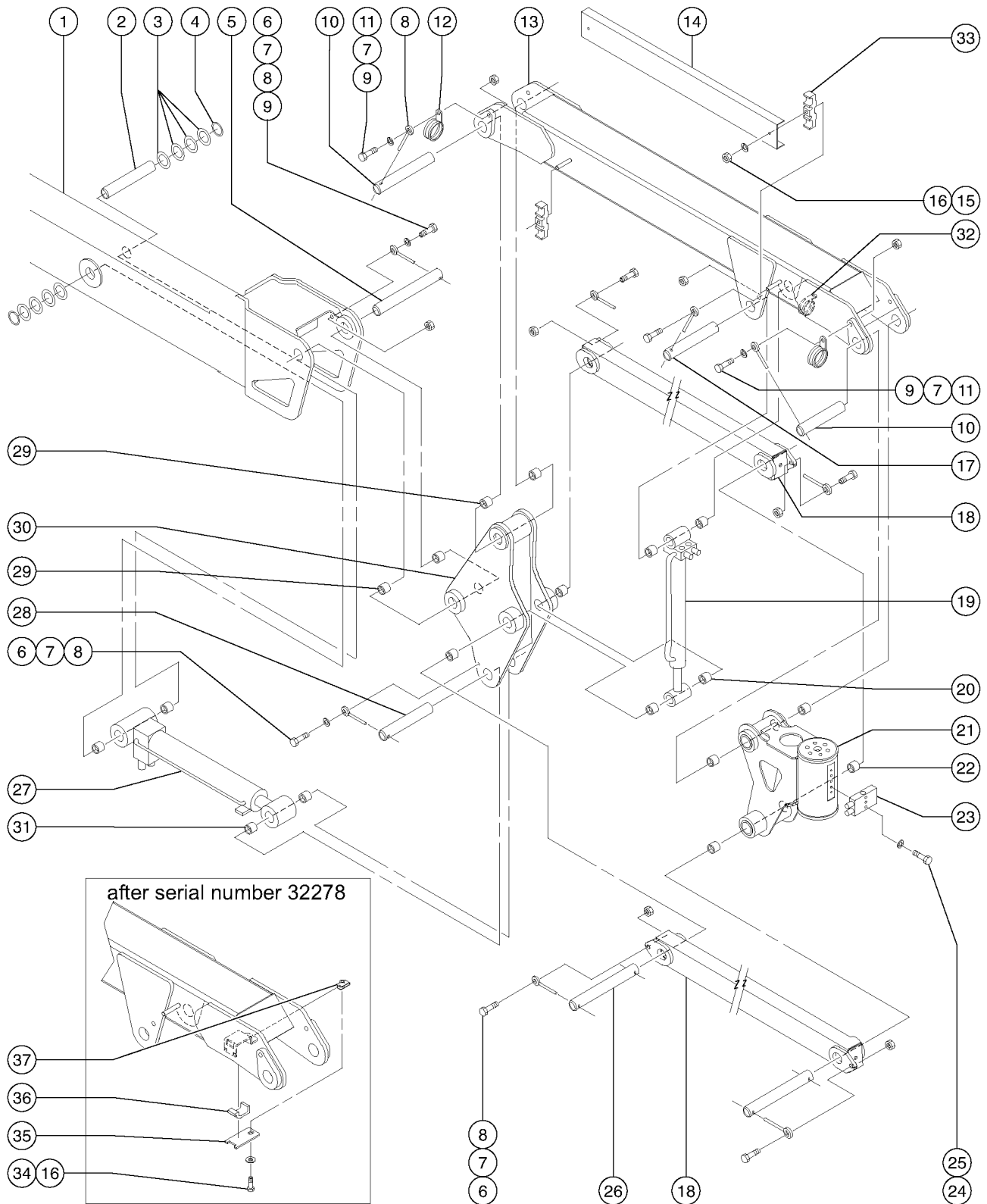

407.1 Jib Platform Leveling (Z-45/25J)

Item	Part No.	Description	Qty.	Item	Part No.	Description	Qty.
--	150103GT	WIRE LOOM,1.25"NYLON,HIGH TEMP.....129-inches		30	50466-SGT	BELLCRANK,JIB,WELD/Z45/25***1 <i>includes item 29</i>	
1		Ref. Primary and Extension Booms (refer to 504.1)		31	25683GT	BEARING,POLYGON,20DU12.....2	
2	50546GT	PIN,1.25DIAX6.36LG,2RING.....1		32	49863GT	CLAMP,1.13,#18 X 3/8,RUB CUSH*.....1	
3	30255GT	WASHER,SHIM,1.27 X 2.13 X .062		33	106581GT	CLAMP,JIB HOSE Z45.....2	
4	824164GT	SNAP RING,EXTERNAL,1.25,ZAG		--	128428GT	ARCTIC HOSES, Z45J ELEVATE <i>Artic Option</i>	
5	50543GT	PIN,1.25DIAX8.88LG,1HOLE.....1		34	6090GT	SCREW,HHC,1/4-20 X .75	
6	6019GT	SCREW,HHC,3/8-16 X 1.25 GRD 5		35	119536PGT	BRACKET,HOSE CLAMP,PAINTED.....1	
7	5397GT	WASHER,FLAT,USS,5/16",Y		36	119542GT	CLAMP,TWO HOSE.....1	
8	825019GT	ROD END,.375X3.69,ZAG		37	56912GT	SPRING CLIP,1/4-20,.025-.15X.54,ZAG	
9	4828GT	NUT,NYLOCK,3/8-16					
10	T107883GT	PIN,1.25DIAX7.88LG,1HOLE.....2					
11	8516GT	SCREW, HCC, 3/8-16 X 1.50					
12	27497GT	CLAMP,RUBBER CUSHIONED-2 5/32....2					
13		SERVICE KIT, 5FT JIB.....1 <i>Refer to section 509.1 for jib detail</i>					
14	106540PGT	CABLE COVER,JIB PAINTED.....1					
15	6091GT	NUT,NYLOCK,1/4-20					
16	5397GT	WASHER,FLAT,USS,5/16",Y					
17	T107884GT	PIN,1.25DIAX7.00LG,1HOLE.....1					
18	61306-SGT	COMPR.LINK,MACHINED,GND CONTR*.....2					
19	54994GT	CYLINDER,JIB,Z45,#4 PORTS***1 <i>includes item 20</i>					
--	147283GT	SEAL KIT,147259 <i>for 147259</i>					
--	43018GT	SEAL KIT (39345) <i>for 50480</i>					
--	50480GT	VALVE,COUNTERBALANCE,3800 PSI*					
--	65789GT	SEAL KIT (54994) <i>for 54994</i>					
20	25683GT	BEARING,POLYGON,20DU12.....4					
21		REF: Jib Platform rotator.....1 <i>Refer to section 508.1 for jib rotator</i>					
22	30222GT	BEARING,FL,1.25IDX1.41ODX1.50L.....4					
23		Ref. Counterbalance Manifold (refer to 703.1)					
24	8915GT	SCREW,HHC,1/4-20 X 1.25					
25	6356GT	WASHER,LOCK,.25					
26	81175GT	PIN,1.25DIAX14.45LG,2HOLE.....2					
27	77363GT	CYLINDER,SLAVE,Z45***1 <i>includes item 31</i>					
--	54065GT	VALVE,COUNTERBALANCE,3500***					
--	77364GT	SEAL KIT,MASTER & SLAVE CYL					
28	T108075GT	PIN,1.25DIAX5.25LG,1HOLE.....1					
29	35675GT	BEARING,FL,1.25IDX1.5ODX1.25L.....6					



408.1 Jib Platform Rotation (Z-45/25J)

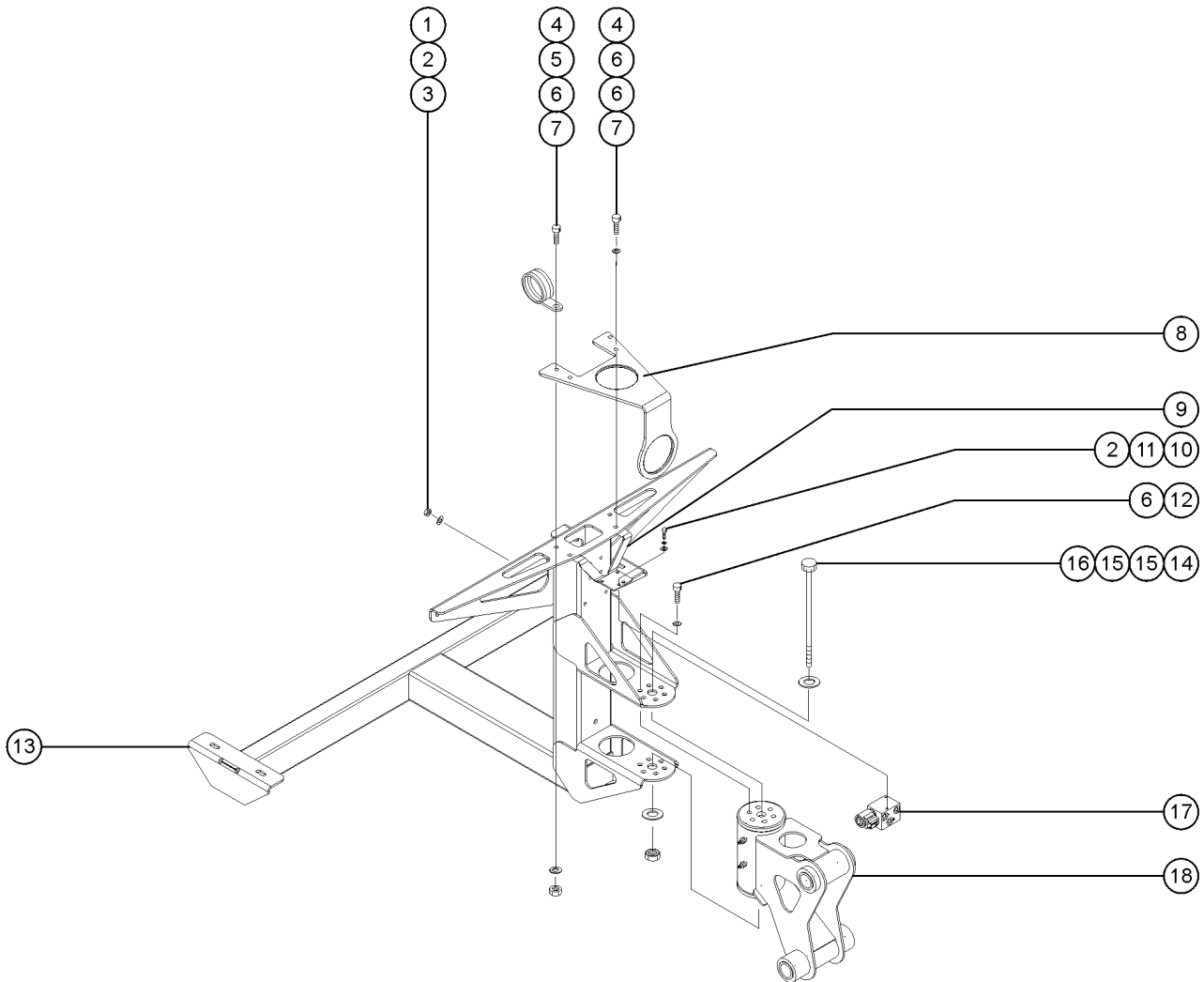

408.1 Jib Platform Rotation (Z-45/25J)

Item	Part No.	Description	Qty.
1	6091GT	NUT,NYLOCK,1/4-20	
2	6638GT	WASHER,FLAT,USS,1/4"Y	
3	36294GT	SCREW,HHC,1/4-20 X 2.75	
4	13002GT	SCREW,HHC,5/16-18 X 1 GR5	
5	49863GT	CLAMP,1.13,#18 X 3/8,RUB CUSH*.....1	
6	5397GT	WASHER,FLAT,USS,5/16",Y	
7	6782GT	NUT,NYLOCK,5/16-18	
8	106163GT	FORMING,CABLE GUIDE.....1 <i>order 55067 grommet separately</i>	
--	55067GT	GROMMET,RUBBER 3 X .19 X 3.5.....2	
9	110671GT	PLATE,JIB,ROTATE MANIFOLD.....1	
10	6090GT	SCREW,HHC,1/4-20 X .75	
11	6356GT	WASHER,LOCK,.25	
12	94195GT	SCREW,HHC,3/8-16 X .75,GR 8.....6	
13	54510-SGT	WELDMENT,PLATFORM SUPPORT <i>for models with the Platform Overload option, refer to 907.1</i>	
14	56925GT	SCREW,HHC,3/4-10 X 9.5 GR 8 YE.....1	
15	33278GT	WASHER,FLAT,.75 HARDENED	
16	77051GT	NUT,NYLOCK,3/4-10,GRD.8.....1	
17		Ref. Jib Manifold (refer to 703.1)	
18A		ROTATOR,PLAT,Z45 <i>originally to SN 43877, PN no longer available, replace with 233715</i>	
--	147369GT	SEAL AND BRG KIT,4.5K ROTATOR* <i>for 94401</i>	
--	30222GT	BEARING,FL,1.25IDX1.41ODX1.50L.....4 <i>for 94401</i>	
--	88516GT	SCREW,BLEEDER,M5X0.8.....2 <i>for 94401</i>	
18B	233715GT	ROTATOR,PLAT,Z45J/Z51J.....1 <i>replacement for 94401</i>	
--	233745GT	SEAL AND BRG KIT,4.5K ROTATOR <i>for 233715</i>	
--	30222GT	BEARING,FL,1.25IDX1.41ODX1.50L.....4 <i>for 233715</i>	
--	88516GT	SCREW,BLEEDER,M5X0.8.....2 <i>for 233715</i>	

409.1 Jib Detail (Z-45/25J)

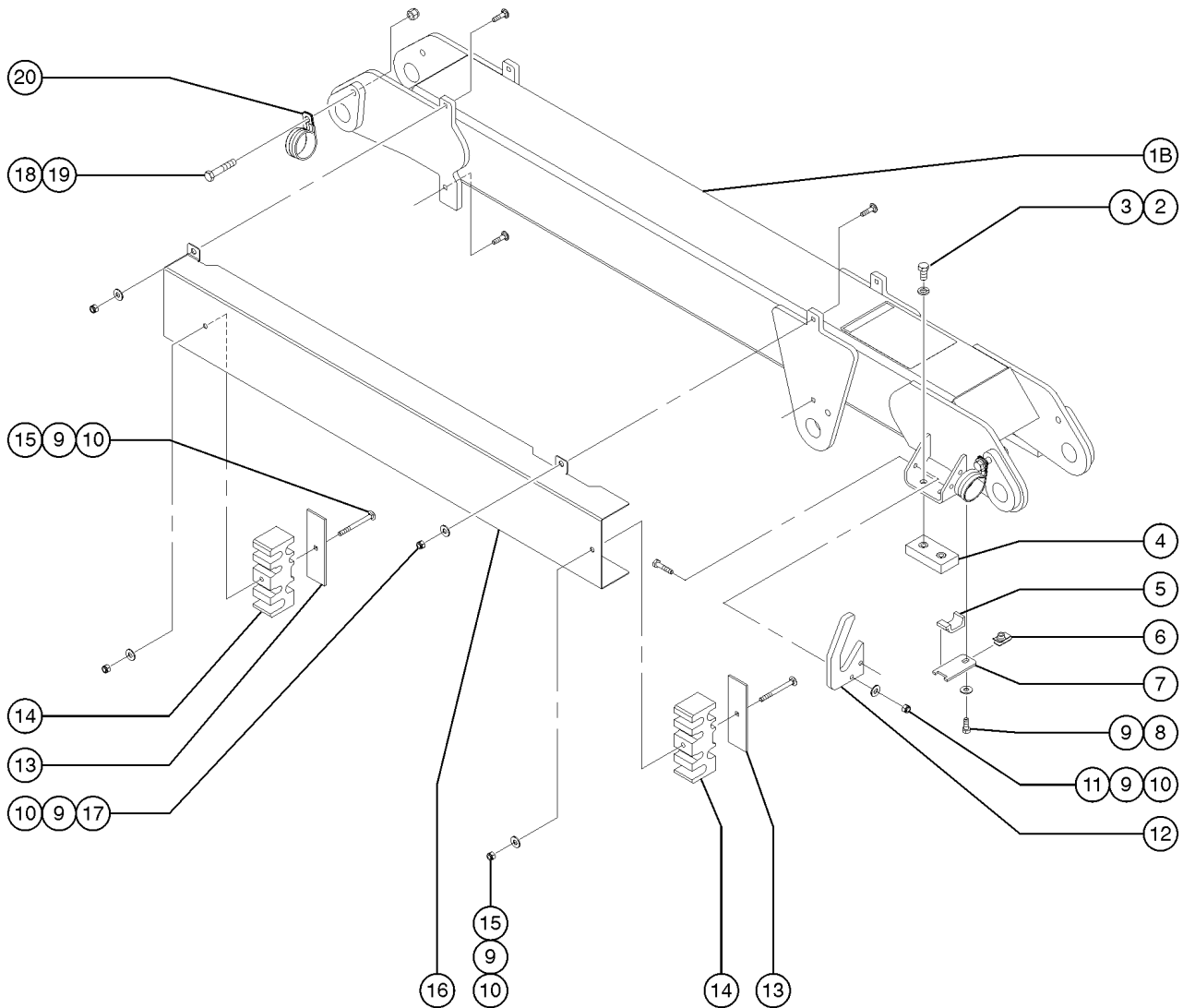
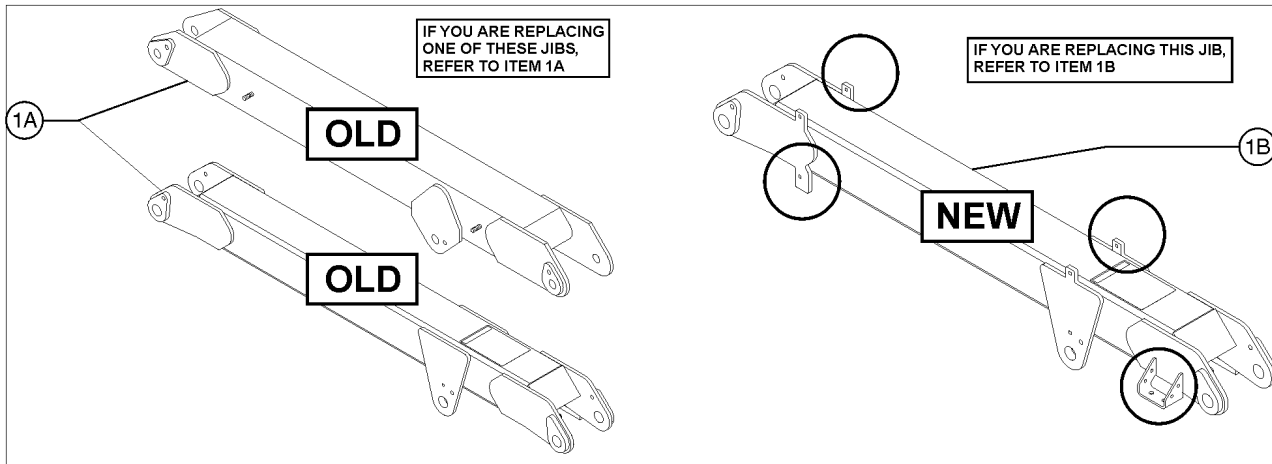

409.1 Jib Detail (Z-45/25J)

Item	Part No.	Description	Qty.
1A	128513GT	SERVICE KIT,5FT JIB <i>required for first time replacement (includes part number 128534)</i>	
1B	128534GT	JIB BOOM ASSY W/WORD DECAL.....1 <i>use ONLY if service kit 128513 has been installed on the machine</i>	
2	8255GT	SCREW,HHC,3/8-16 X .75	
3	6021GT	WASHER,LOCK,.375	
4	81640GT	WEAR PAD,3 X 1.5 X.625 W/NUTS.....1	
5	119542GT	CLAMP,TWO HOSE.....1	
6	56912GT	SPRING CLIP,1/4-20,.025-.15X.54,ZAG.....1	
7	119536PGT	BRACKET,HOSE CLAMP,PAINTED.....1	
8	6090GT	SCREW,HHC,1/4-20 X .75	
9	6638GT	WASHER,FLAT,USS,1/4"Y	
10	6091GT	NUT,NYLOCK,1/4-20	
11	8915GT	SCREW,HHC,1/4-20 X 1.25	
12	128482GT	HOSE GUIDE, JIB.....1	
13	128483GT	BACKING PLATE, HOSE BLOCK, JIB....2	
14	128510GT	CLAMP,JIB HOSE/CABLE,Z45/51.....2	
15	128724GT	BOLT,CARRIAGE,1/4-20 X 2.75,G2	
16	128454PGT	COVER, JIB HOSES/CABLES.....1	
17	79456GT	BOLT,CARRIAGE,1/4-20 X 1.00,G2	
18	5224GT	SCREW,HHC,3/8-16 X 2	
19	4828GT	NUT,NYLOCK,3/8-16	
20	77181GT	CLAMP,1.63,#26 X 3/8,RUB CUSH.....2	

501.1 Platform Configuration

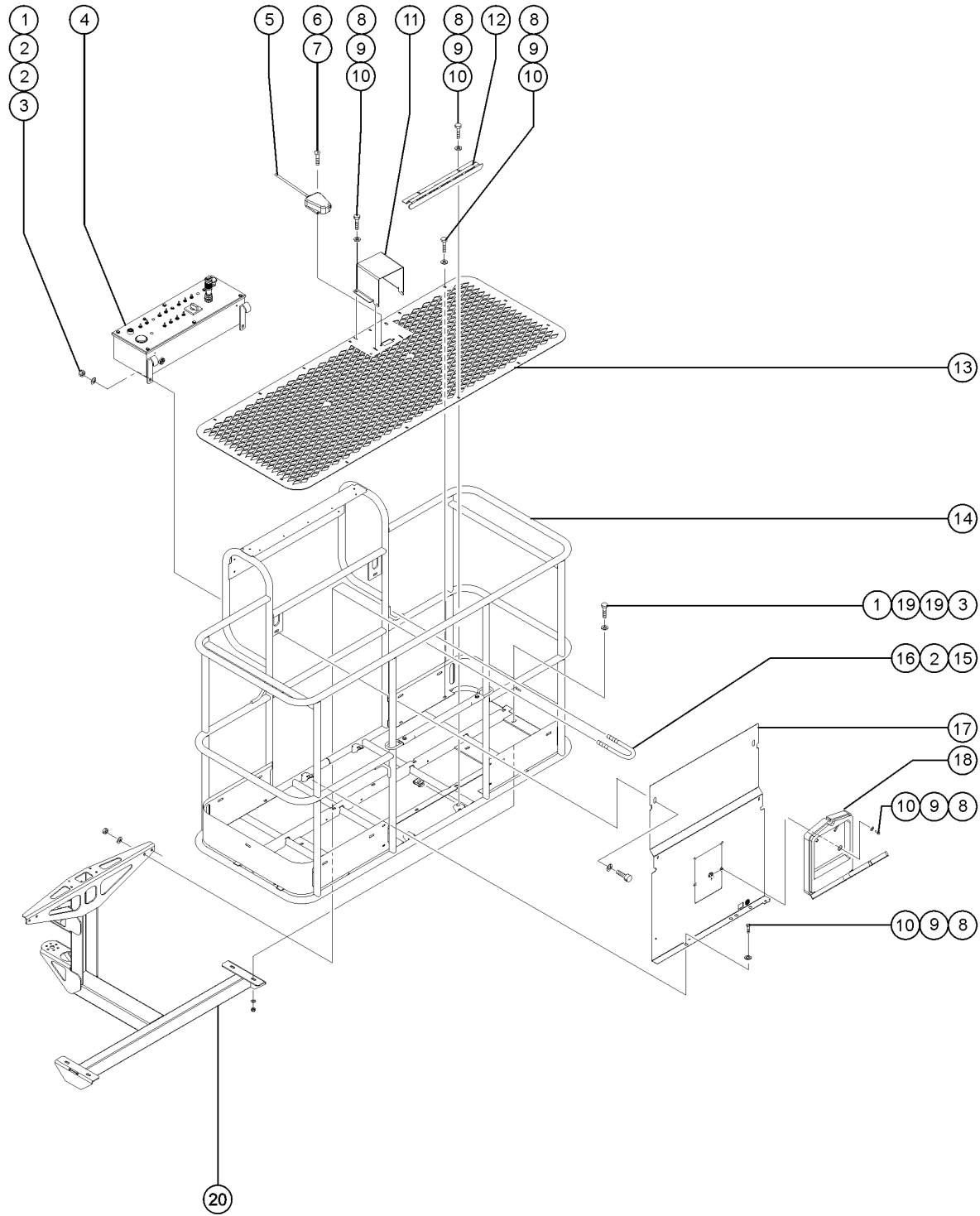

501.1 Platform Configuration

Item	Part No.	Description	Qty.
A		<i>Complete Platform Assemblies with Decals</i>	
--			
--	1275393GT	PLAT ASSY,6' W/SIDE GATE,Z45DC/BI ANSI WORD <i>USA and Canadian models</i>	
--	1275394GT	PLAT ASSY,6' W/SIDE GATE,Z45DC/BI AUS <i>Australian models (to 34010) (from SN A-34011 to A-40599)(from SN B-101 to B-1725)</i>	
--	1275395GT	PLAT ASSY,6' W/SIDE GATE,Z45/51 CE <i>European models</i>	
--	1275396GT	PLAT ASSY,6' W/SIDE GATE,Z45/51 ANSI SYM <i>Asia/South America models</i>	
--	1275397GT	PLAT ASSY,6' W/SIDE GATE,Z45DC/BI AUS <i>Australian models (from SN A-40560)(from SN B-1726)(from SN D-101)</i>	
B		<i>Complete Platform Assemblies and Platform Weldments without Decals (Warning tape & decals not included, refer to section 100 for decals)</i>	
--			
1A	1272303GT	ASSY,6FT PLAT DUAL LG,BLANK W/SIDE SWING GATE	
--	1274858GT	ASSY,6' PLAT WELDMENT W/SIDE GATE <i>flooring and decal plate not included</i>	
2A	161541GT	ASSY,4FT PLATFORM, NO DECALS <i>Single entry</i>	
--	60042GT	WELDMENT,4 FT PLATFORM <i>flooring and decal plate not included</i>	
2B	161542GT	ASSY,5FT PLATFORM, NO DECALS <i>Single entry</i>	
--	50294GT	WELDMENT,5 FT PLATFORM <i>flooring and decal plate not included</i>	
2C	160809GT	ASSY,6FT PLATFORM,NO DECALS <i>Single entry</i>	
--	73900GT	WELDMNT,6 FT PLATFORM <i>flooring and decal plate not included</i>	

502.1 Platform Components

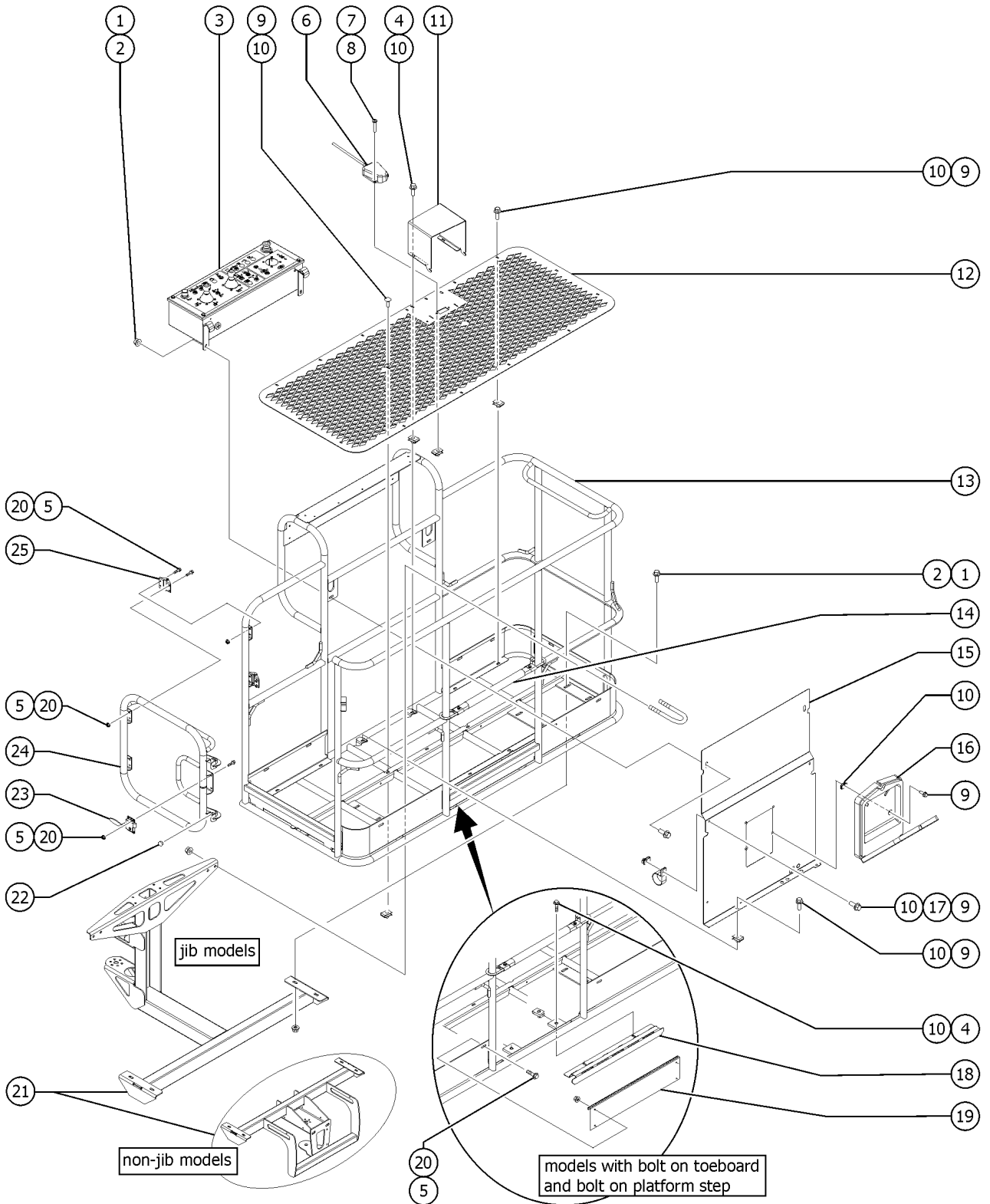

502.1 Platform Components

Item	Part No.	Description	Qty.	Item	Part No.	Description	Qty.
1	824029GT	NUT,TL FLG,3/8-16,G,ZAG		20	1256855GT	SCREW,HHF,1/4-20X.625,8,ZAG	
2	824090GT	SCREW,HHF,3/8-16X1,8,ZAG		21A		WELDMENT, Z45 PLATFORM SUPPORT, NO JIB.....1 <i>(refer to 506.1) (non-jib models)</i>	
3		Ref. Platform Control Box <i>(refer to 602.1 and 603.1)</i>		21C		Ref. Platform Support.....1 <i>(refer to 906.1) (models with platform overload option)</i>	
4	824079GT	SCREW,HHF,1/4-20X1,8,ZAG		22	43392GT	BUMPER,BATTERY BOX & RAILS.....2	
5	824027GT	NUT,TL FLG,1/4-20,G,ZAG.....2		23	1267747GT	LATCH, SWING GATE.....1	
6A	73233GT	ASSEMBLY,FOOT SWITCH***.....1 <i>(to SN 41836)</i>		24	1272307GT	ASSY,SIDE SWING GATE.....1	
--	119058GT	CONN PLUG 4 WAY ENDCAP DT <i>(for PN 73233)</i>		25	104804GT	HINGE, SPRING, LONG LEG.....2	
--	20262GT	MICROSWITCH,13482 FOOTSWITCH <i>(for PN 73233)</i>					
--	43960GT	WIRE CABLE,16/4 CON.TPE JKT.....66-inches <i>(for PN 73233)</i>					
--	73739GT	BOOT,PLUG 4 WAY <i>(for PN 73233)</i>					
6B	228468GT	KIT, FOOTSWITCH, Z45 & Z51.....1 <i>(upgrade kit) (to SN 41836)</i>					
--	227617GT	ASSEMBLY,FOOT SWITCH <i>(for PN 228468)</i>					
6C	227617GT	ASSEMBLY,FOOT SWITCH.....1 <i>(from SN 41837)</i>					
7	1256460GT	SCREW,PHPM,10-24X1,ZAG.....2					
8	73575GT	SPRING CLIP,10-24,.025-.125X.468,ZAG.....2					
9	824078GT	SCREW,HHF,1/4-20X.75,8,ZAG					
10	56912GT	SPRING CLIP,1/4-20,.025-.15X.54,ZAG					
11	147121GT	COVER, FOOT SWITCH, LARGE.....1					
12A	1267746GT	FLOORING, 6FT PLAT,SIDE.....1					
12B	73477PGT	FLOORING, 6'FT PLATFORM.....1 <i>(for single entry)</i>					
12C	54247PGT	FLOORING,5 FT PLATFORM,PAINTED.....1					
12D	60160PGT	FLOORING,4 FT PLATFORM,PAINTED.....1					
13		Ref. Platform Weldment.....1 <i>(refer to 601.1)</i>					
14	102992GT	SLIDING MIDRAIL KIT,PTD.....1 <i>(includes fasteners)</i>					
15	73574-SGT	DECAL PLATE ASSEMBLY.....1 <i>(decals not included, refer to section 100)</i>					
16	24514GT	BOX,INSTRUCTION STORAGE.....1 <i>(decals not included, refer to section 100)</i>					
17	56424GT	CLAMP,1.25X.5 RUBBER-CUSHION.....2					
18	73610PGT	STEP PLATFORM ENTRY PAINTED***1					
19	94745GT	TOEBOARD,ENTRY EUROPEAN PNTD**1					



503.1 Platform Controls

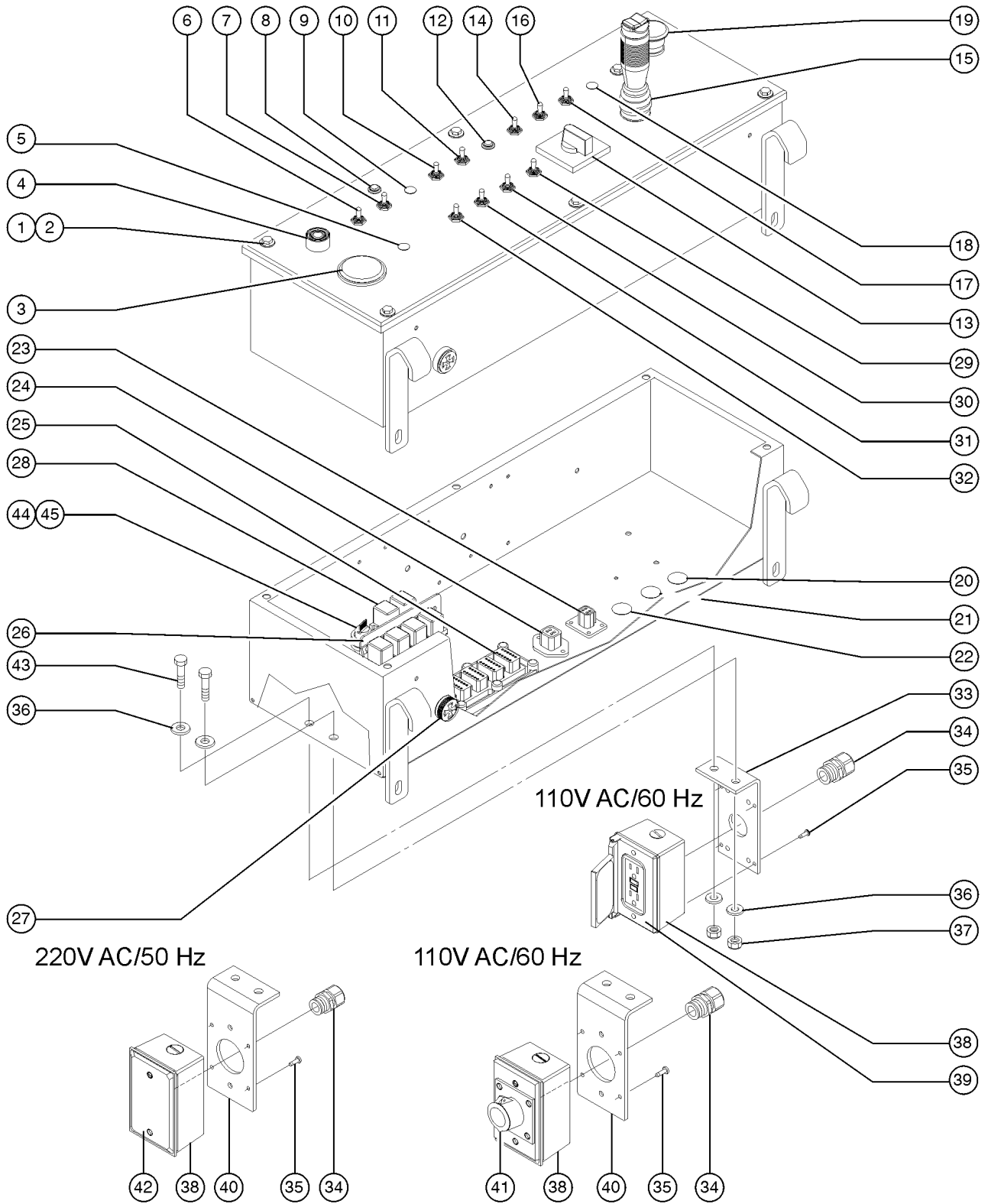

503.1 Platform Controls

Item	Part No.	Description	Qty.	Item	Part No.	Description	Qty.
--	101579GT	PLAT. CONTROL BOX W/DECAL		13	36557GT	ROTATIONAL CONTROLLER,24V***	
--	147253GT	TIME DELAY RELAY,2 SEC,24VDC		14	128202GT	SWITCH TOGGLE ASSY DPDT 3P MOM.....1 <i>Glow Plug; includes boot and hardware</i>	1
1	8914GT	SCREW,HHC,1/4-20 X .625		--	128578GT	SCREW T-SWITCH PH/PH 6-32X1/4	
2	6638GT	WASHER,FLAT,USS,1/4"Y		--	128582-SGT	SWITCH TOGGLE DPDT 3P MOM SHDR	
--	110652GT	GASKET LVI/BCI ENGAGE II		--	27246GT	BOOT,TOGGLE SWITCH,SHORT*	
--	110653GT	BRACKET ENGAGE II		15		Ref. Joystick, Drive/Steer (refer to 603.1 or 604.1)	
--	110654GT	CONN PLUG 8 WAY MOLEX		16A	128200GT	SWITCH TOGGLE ASSY SPDT 3P MOM.....1 <i>Engine Star (Bi-Energy); includes boot and hardware</i>	1
3A	237145GT	IND,BAT CHARGE,48V LEAD-ACID.....1 <i>(models with battery charge indicator)</i>	1	--	128578GT	SCREW T-SWITCH PH/PH 6-32X1/4	
3B	110651GT	LVI/BCI 36/48 VOLT ENGAGE II.....1 <i>(models with low voltage indicator/battery charge indicator) from SN 31015</i>	1	--	128580-SGT	SWITCH TOGGLE SPDT 3P MOM SHDR	
4	122513GT	KIT,HORN SVC BB&SM BOOM		--	27246GT	BOOT,TOGGLE SWITCH,SHORT*	
--	66813GT	BUTTON,PUSH,BLACK W/SEAL***		16B	45384GT	PLUG,NYLON .50 BLACK DOMED (DC)	
--	66815GT	BASE, W/1 N.O. CONTACTS***		17	13037-SGT	SWITCH,TOGGLE,SPDT,3POS MOMEN*.....1	1
5	229567GT	PLUG,SANTOPRENE .5 BLACK DOME		18	45384GT	PLUG,NYLON .50 BLACK DOMED	
6	128201GT	SWITCH TOGGLE ASSY DPDT 2P MOM.....1 <i>Auxiliary Power; includes boot and hardware</i>	1	19	122514GT	KIT,ESTOP SVC BB&SM BOOM	
--	128578GT	SCREW T-SWITCH PH/PH 6-32X1/4		--	146478GT	BOOT(BELLOWS),E-STOP,BLACK	
--	128581-SGT	SWITCH TOGGLE DPDT 2P MOM SHDR		--	66812GT	BUTTON,PUSH,RED MUSHROOM HEAD	
--	27246GT	BOOT,TOGGLE SWITCH,SHORT*		--	66818GT	CONTACT, N.C.	
7	128200GT	SWITCH TOGGLE ASSY SPDT 3P MOM.....1 <i>Drive Enable; includes boot and hardware</i>	1	--	66821GT	BASE,WITHOUT CONTACTS	
--	128578GT	SCREW T-SWITCH PH/PH 6-32X1/4		20	45385GT	PLUG,NYLON 1.12 BLACK DOMED	
--	128580-SGT	SWITCH TOGGLE SPDT 3P MOM SHDR		21	45385GT	PLUG,NYLON 1.12 BLACK DOMED	
--	27246GT	BOOT,TOGGLE SWITCH,SHORT*		22	45385GT	PLUG,NYLON 1.12 BLACK DOMED	
8	42725GT	LIGHT,INDICATOR,RED 28V.....1	1	23	73233GT	ASSEMBLY,FOOT SWITCH***	
9B	128202GT	SWITCH TOGGLE ASSY DPDT 3P MOM.....1 <i>(Z-45/25J) Jib Boom Up/Down; includes boot and hardware</i>	1	23	73723GT	CONN RECEPT,FLANGED	
10	128202GT	SWITCH TOGGLE ASSY DPDT 3P MOM.....1 <i>Platform Rotate; includes boot and hardware</i>	1	--	54259GT	TERM,NI PIN, 14-16GA,BULK	
--	128578GT	SCREW T-SWITCH PH/PH 6-32X1/4		--	60443GT	LOCK,RECEP 4 WAY,14-18GA	
--	128582-SGT	SWITCH TOGGLE DPDT 3P MOM SHDR		24	73717GT	CONN,RECEP 4 WAY,12-14GA FL***	
--	27246GT	BOOT,TOGGLE SWITCH,SHORT*		--	60526GT	LOCK,RECEP 4 WAY,12-14GA	
11	128202GT	SWITCH TOGGLE ASSY DPDT 3P MOM.....1 <i>Platform Level; includes boot and hardware</i>	1	--	73711GT	TERM,DEUTSCH, PIN #12-14	
--	128578GT	SCREW T-SWITCH PH/PH 6-32X1/4		25	73736GT	CONN,RECEP 48 WAY,4 X 12.....1	1
--	128582-SGT	SWITCH TOGGLE DPDT 3P MOM SHDR		--	54255GT	LOCK,RECEP 12 WAY, 14-18GA	
--	27246GT	BOOT,TOGGLE SWITCH,SHORT*		--	73713GT	TERM,NI PIN,S&F,16-18GA,REEL	
12	218164GT	LIGHT,INDICATOR,RED 24V H-BRI		26	T106699GT	BRACKET,RELAY MOUNT W/INSERTS.....1	1
				27	45383GT	ALARM,WARBLE TONE 5-30 VDC***.....1 <i>does not include 72326 nut</i>	1
				--	72326GT	NUT - PLASTIC,RING FOR ALARMS <i>must order serparately</i>	
				28	56302GT	RELAY,24VDC,40/30A,SEALED***.....6	6

503.1 Platform Controls (continued)

Item	Part No.	Description	Qty.
29	128202GT	SWITCH TOGGLE ASSY DPDT 3P MOM.....1 <i>Primary Boom Ext/Ret; includes boot and hardware</i>	
--	128578GT	SCREW T-SWITCH PH/PH 6-32X1/4	
--	128582-SGT	SWITCH TOGGLE DPDT 3P MOM SHDR	
--	27246GT	BOOT,TOGGLE SWITCH,SHORT*	
30	128202GT	SWITCH TOGGLE ASSY DPDT 3P MOM.....1 <i>Primary Boom Up/Down; includes boot and hardware</i>	
--	128578GT	SCREW T-SWITCH PH/PH 6-32X1/4	
--	128582-SGT	SWITCH TOGGLE DPDT 3P MOM SHDR	
--	27246GT	BOOT,TOGGLE SWITCH,SHORT*	
31	128202GT	SWITCH TOGGLE ASSY DPDT 3P MOM.....1 <i>Secondary Boom Up/Down; includes boot and hardware</i>	
--	128578GT	SCREW T-SWITCH PH/PH 6-32X1/4	
--	128582-SGT	SWITCH TOGGLE DPDT 3P MOM SHDR	
--	27246GT	BOOT,TOGGLE SWITCH,SHORT*	
32	128202GT	SWITCH TOGGLE ASSY DPDT 3P MOM.....1 <i>Turntable Rotate; includes boot and hardware</i>	
--	128578GT	SCREW T-SWITCH PH/PH 6-32X1/4	
--	128582-SGT	SWITCH TOGGLE DPDT 3P MOM SHDR	
--	27246GT	BOOT,TOGGLE SWITCH,SHORT*	
33	81096GT	BRACKET,POWER TO PLAT, DOM.....1	
34	7056GT	CONN,SQUEEZE,1/2NPT .38-.50,SM....2	
--	6935GT	LOCKNUT,ELEC,1/2"	
35	57075GT	SCREW,PHIL,8-32X.50,SELF TAP.....4	
35A	35461GT	WASHER,FLAT,MS,#8,Y.....4	
36	5397GT	WASHER,FLAT,USS,5/16",Y	
37	4828GT	NUT,NYLOCK,3/8-16	
38	10775GT	T-BOX,2.75 X 4.5 X 2.0.....1	
39	13585GT	OUTLET, 110V.....1 <i>USA/Canada</i>	
--	74006GT	COVER,GFCI,HORIZONTAL,WEATHER <i>USA/Canada</i>	
40	81096GT	BRACKET,POWER TO PLAT, DOM.....1	
41	T112560GT	RECEPTACLE,UK,110V.....1	
42	10777GT	COVER,BLANK.....1	
--	33724GT	KIT,GASKET,UK POWER TO PLAT.	
--	81458GT	GASKET, UK POWER TO PLAT	
43	6019GT	SCREW,HHC,3/8-16 X 1.25 GRD 5	
44	43181GT	CAPACITOR,TIME DELAY.....1	
45	13268GT	CLAMP,0.75,#12 X 1/4,RUB CUSH.....1	

This Page Intentionally Left Blank

504.1 Joystick Controller, Drive/Steer Functions

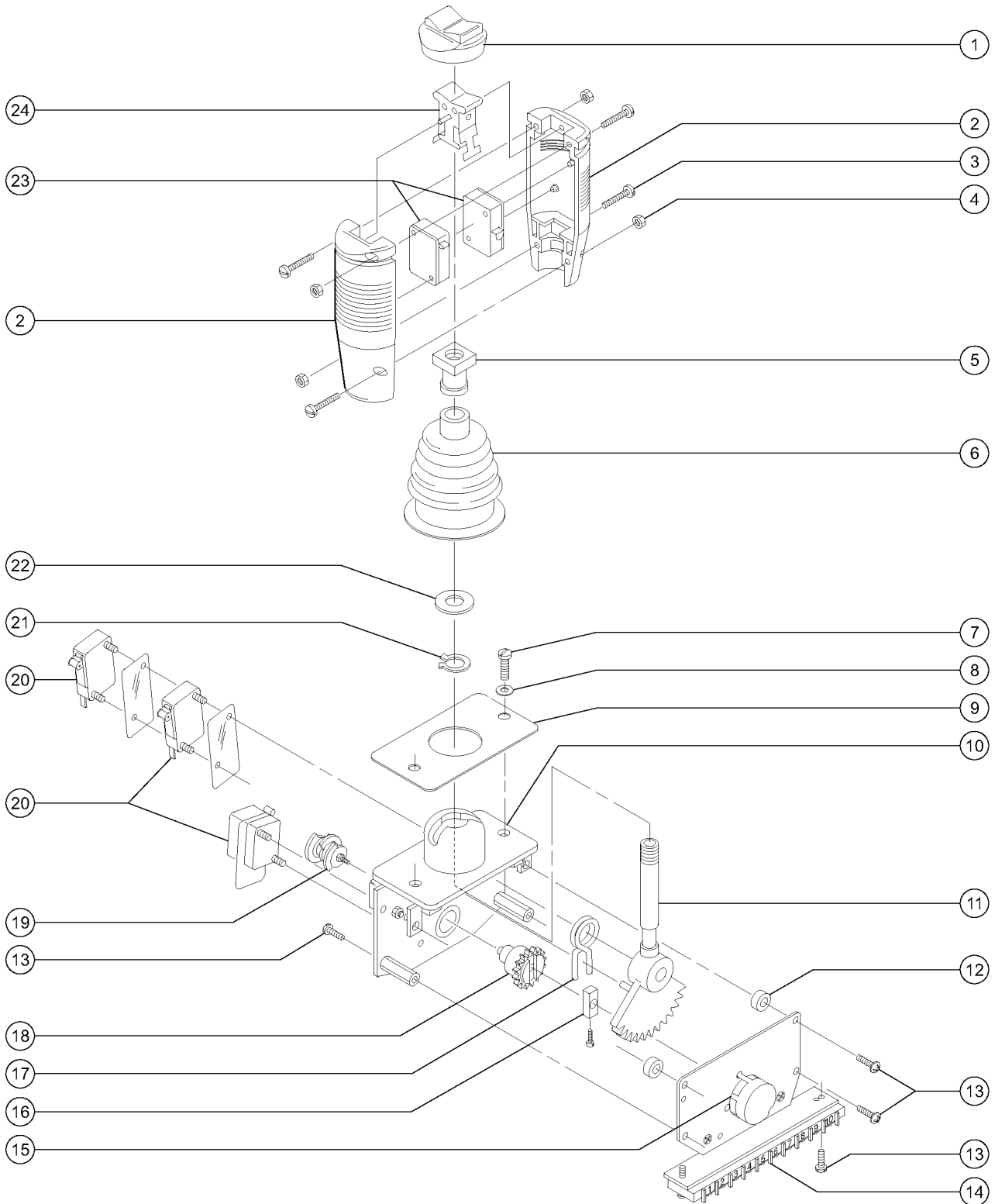

504.1 Joystick Controller, Drive/Steer Functions

Item	Part No.	Description	Qty.
A	56773GT	JOYSTICK,5K-0 OHM (10-pin connector) (to SN Z452513A-45734)	
B	234923GT	JOYSTICK,5K-0 OHM,W/RELAY (12-pin connector) (from SN Z452513A-45735)	
--	78098GT	RELAY,24VDC,40/30A,SLD W/BRKT* (from SN Z452513A-45735, for 234923, includes bracket)	
Z	1269501GT	KIT, ISOLATION, 3 JOYSTICK	
1	43038GT	BOOT-THUMB ROCKER** BLACK.....	1
2	52887GT	HANDLE HALF (56274).....	2
3	52895GT	SCREW,PHM,M3 X .5 X 12MM	
4	52928GT	NUT-HEX,3M X 0.5MM	
5	43040GT	NUT,JS,36867/42032/44988/40612.....	1
6	21427GT	BOOT,CONTROLLER**.....	1
7	49816GT	SCREW,PHILLIPS,PHM,10-32 X .75	
8	74362GT	WASHER,NYLON, JOYSTICK	
9	43042GT	GASKET,JOYSTK.SHAFT36867/42032..	1
10	58987GT	CASTING 42032.....	1
11	46227GT	SHAFT ASSY, JOYSTICK***..... <i>includes gear</i>	1
12	74368GT	SPACER-POT.PLATE,JOYSTICK56773..	1
13	65546GT	SCREW,PHM,M3.5 X 12MM (57890)	
14	74367GT	TERM.BUSS,10POLE,JOYSTICK56773.	1
15	72298GT	POTENTIOMETER (56773).....	1
16	65529GT	COUPLING-POT,JOYSTICK (56579)....	1
17	21434GT	SPRING & BUSHING KIT,RETURN***...1	1
18	19731GT	GEAR, SLAVE, MS4,45048.....	1
19	74364GT	CAM ASSEMBLY, JOYSTICK(42032)....	1
20	19712GT	MICROSWITCH,V3L-139-D8.....	1
21	74365GT	C-CLIP, SHAFT, JOYSTICK.....	1
22	74366GT	WASHER, FLAT, SHAFT, JOYSTICK	
23	19722GT	MICROSWITCH-V319M***.....	2
24A	58986GT	ROCKER ASSY (42032)*** <i>for joystick 56773</i>	
24B	65178GT	ROCKER ASSY W/ROLLPIN*** <i>for joystick 234923</i>	

505.1 Rotational Controller

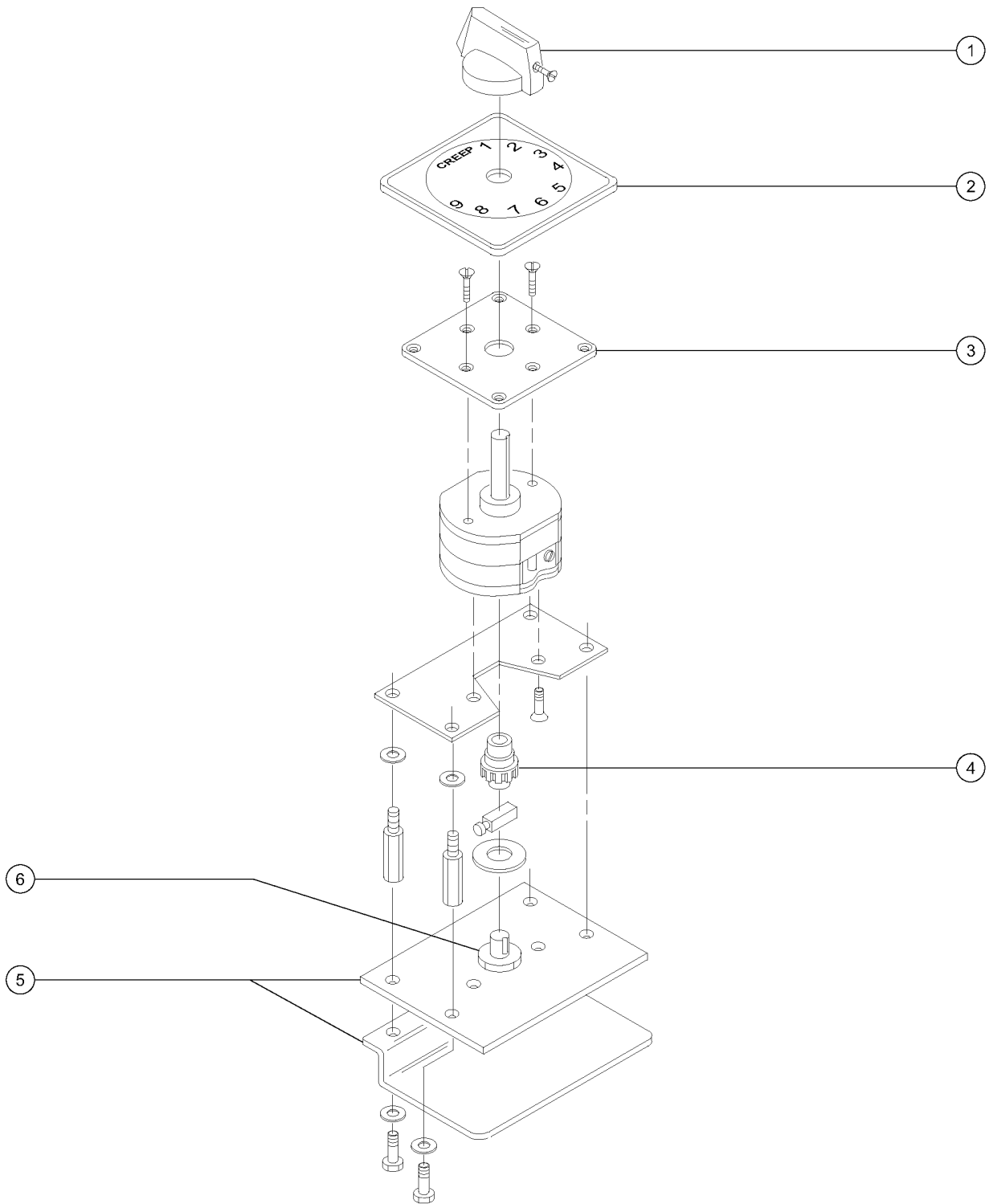

505.1 Rotational Controller

Item	Part No.	Description	Qty.
--	36557GT	ROTATIONAL CONTROLLER,24V***	
1	35679GT	KNOB, 45048 CONTROLLER.....	1
2	35680GT	LEGEND,PLSTC,"CREEP TO 9"***	1
3	35678GT	MOUNTING PLATE, 45048.....	1
4	19731GT	GEAR, SLAVE, MS4,45048.....	1
5	40433GT	PCB,ROTATOR CONTROLLER 36557*.....	1
		<i>includes item 6</i>	
6	19729GT	POTENTIOMETER,56886.....	1

601.1 Hydraulic Power Unit

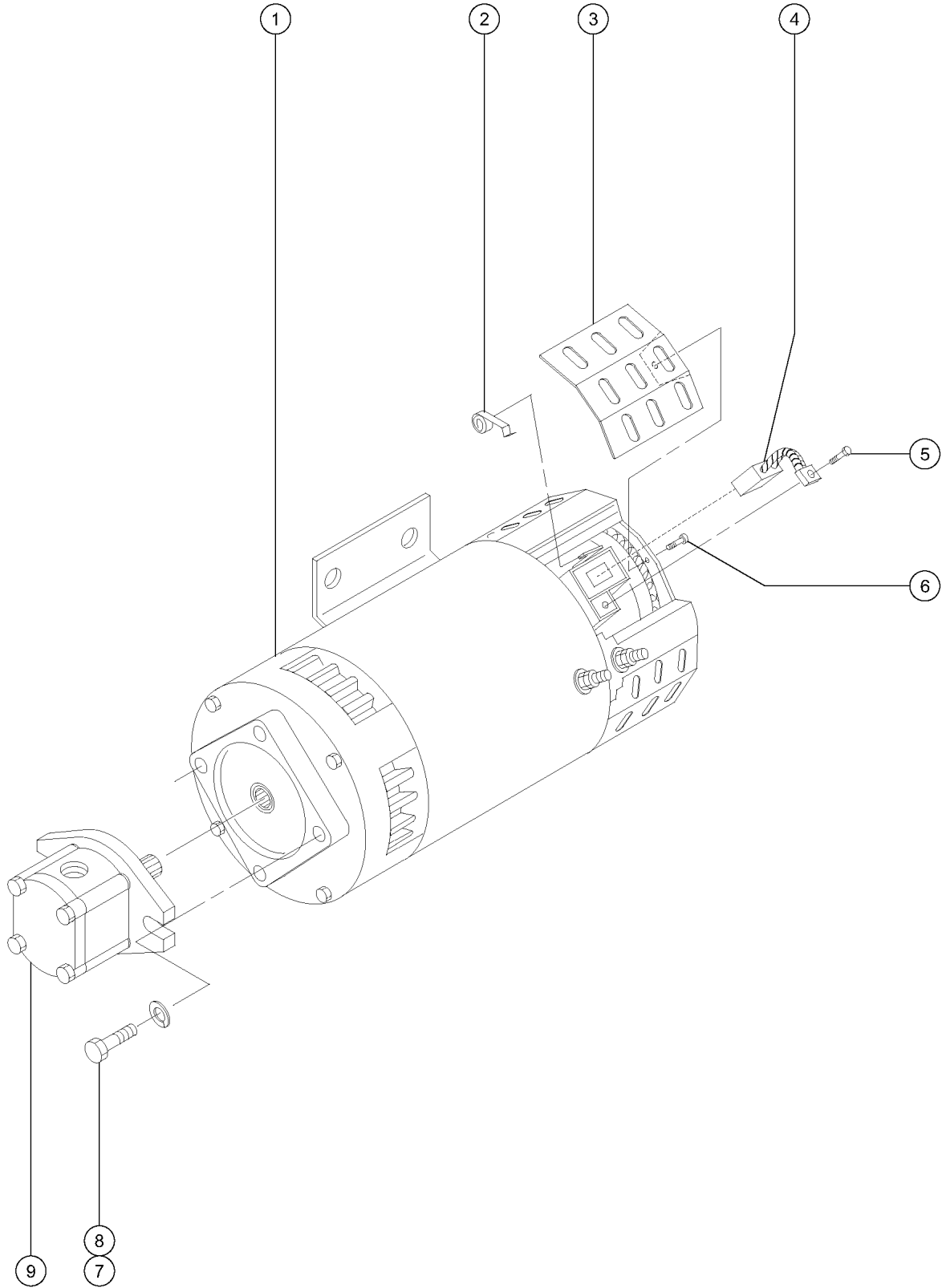

Item	Part No.	Description	Qty.
1	48504GT	MOTOR,FUNCTION,48V DC.....	1
2	44750GT	SPRING-BRUSH,40844, SCISSORS	
3	58936GT	BRUSH COVER -PLATE-(48504)*	1
4	58932GT	BRUSH SET 4 EA.....	1
5	52913GT	SCREW,HH TAPETITE THRD8-32X.50	
6	52914GT	SCREW,HHTAPTITE THREAD8-32X.38	
7	32317GT	SCREW,HHC,3/8-24 X 1 GR 8 YEL	
8	6021GT	WASHER,LOCK, .375	
9	77981GT	PUMP,LIFT,3CC,CCW***	1
--	77990GT	KIT,SEAL,3CC PUMP***	

602.1 Function Manifold

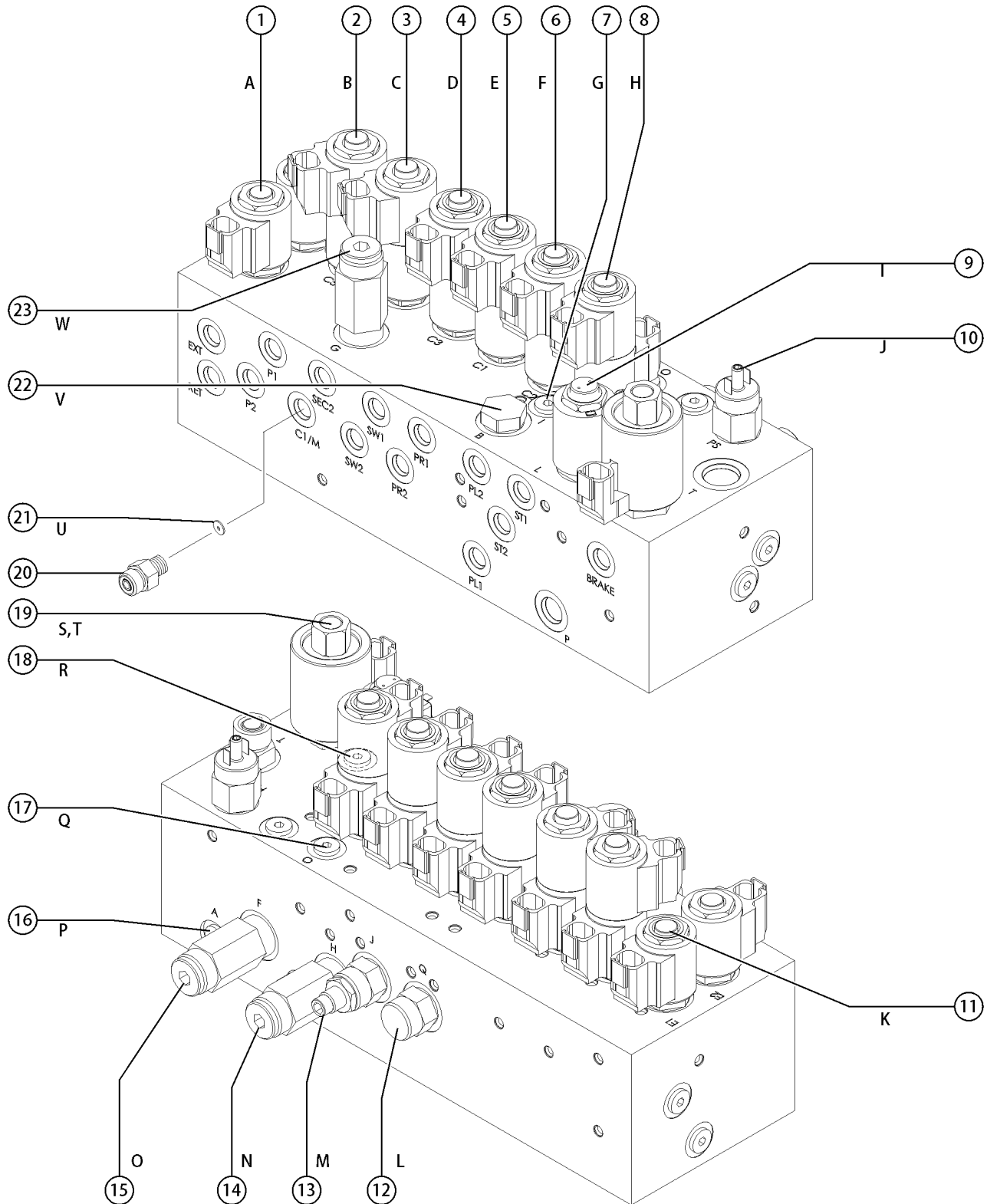

602.1 Function Manifold

Item	Part No.	Description	Qty.	Item	Part No.	Description	Qty.
--	94860GT	MANIFOLD,FUNCTION DC/BI***		--	77709GT	COIL,#8 20VDC,DEUTSCH W/DIOD	
1	52897GT	VALVE,SOLENOID, 2POS/3WAY*** <i>A, Primary boom retract</i>		12	94618GT	VALVE,FLOW CONTROL,.4 GPM <i>L, Platform rotate and turntable rotate circuits</i>	
--	52371GT	SEAL KIT, VALVE		13	101055GT	VALVE,NEEDLE,FINE ADJUSTMENT** <i>M, Platform level circuit</i>	
--	77709GT	COIL,#8 20VDC,DEUTSCH W/DIOD		14	101114GT	VALVE RELIEF,2500PSI(88513)** <i>N, Platform level circuit</i>	
2	39346GT	VALVE,SOLENOID 3 POS.4 WAY*** <i>B, Primary boom up/down</i>		15	52906GT	VALVE-RELIEF,3200 PSI <i>O, System relief</i>	
--	44229GT	SEAL KIT, VALVE		16	52907GT	VALVE-CHECK, #4 SAE, 5 PSI* <i>P, Brake circuit</i>	
--	77709GT	COIL,#8 20VDC,DEUTSCH W/DIOD		17	52910GT	ORIFICE PLUG, 0.060 <i>Q, Steer circuit</i>	
3	39346GT	VALVE,SOLENOID 3 POS.4 WAY*** <i>C, Secondary boom up/down</i>		18	101067GT	ORIFICE PLUG,030,1/16-27 NPT <i>R, Proportional valve circuit</i>	
--	44229GT	SEAL KIT, VALVE		19	101056GT	VALVE,DIRECTIONAL,2-WAY,3 POS <i>S, Brake circuit</i>	
--	77709GT	COIL,#8 20VDC,DEUTSCH W/DIOD		--	101067GT	ORIFICE PLUG,030,1/16-27 NPT <i>T, Brake circuit</i>	
4	39346GT	VALVE,SOLENOID 3 POS.4 WAY*** <i>D, Turntable rotate left/right</i>		--	84385GT	COIL,20VDC DEUTCSH W/DIODE	
--	44229GT	SEAL KIT, VALVE		20	48912GT	CONN,520120-4-6***	
--	77709GT	COIL,#8 20VDC,DEUTSCH W/DIOD		21	129021GT	ORIFICE PLATE,0.037" <i>U</i>	
5	39346GT	VALVE,SOLENOID 3 POS.4 WAY*** <i>E, Platform rotate left/right and jib</i>		22	75453GT	VALVE,CHECK,DUAL PILOT*** <i>V, Platform level circuit</i>	
--	44229GT	SEAL KIT, VALVE		23	101277GT	VALVE,RELIEF,2100 PSI*** <i>W, Secondary boom down circuit</i>	
--	77709GT	COIL,#8 20VDC,DEUTSCH W/DIOD					
6	39346GT	VALVE,SOLENOID 3 POS.4 WAY*** <i>F, Platform level up/down</i>					
--	44229GT	SEAL KIT, VALVE					
--	77709GT	COIL,#8 20VDC,DEUTSCH W/DIOD					
7	826779GT	VALVE,SHUTTLE <i>G, Platform level circuit</i>					
8	52912GT	VALVE,3POSITION,4WAY* <i>H, Steer left/right</i>					
--	44229GT	SEAL KIT, VALVE					
--	77709GT	COIL,#8 20VDC,DEUTSCH W/DIOD					
9A	101057GT	VALVE,PRESS COMP,PROP DIRECT <i>I, Controls flow to functions</i>					
--	101058GT	COIL,24 VDC DUAL SPADE,#8 <i>(to SN 45250)</i>					
9B	101057GT	VALVE,PRESS COMP,PROP DIRECT <i>I, Controls flow to functions</i>					
--	119825GT	COIL, 24V, DEUTSCH NO DIODE <i>(from SN 45251)</i>					
9C	218433GT	BRACKET,MUFFLER,RIGHT <i>(includes new coil 119825, coil adapter harness, and instructions)</i>					
--	119825GT	COIL, 24V, DEUTSCH NO DIODE					
--	216603GT	HARNESS, ADAPER, FLOW COIL					
10	1287986GT	SWITCH,PRESS,#6SAE,600 PSI <i>J, Brake circuit</i>					
11	52897GT	VALVE,SOLENOID, 2POS/3WAY*** <i>K, Primary boom extend</i>					

603.1 Jib Boom and Platform Rotate Manifolds

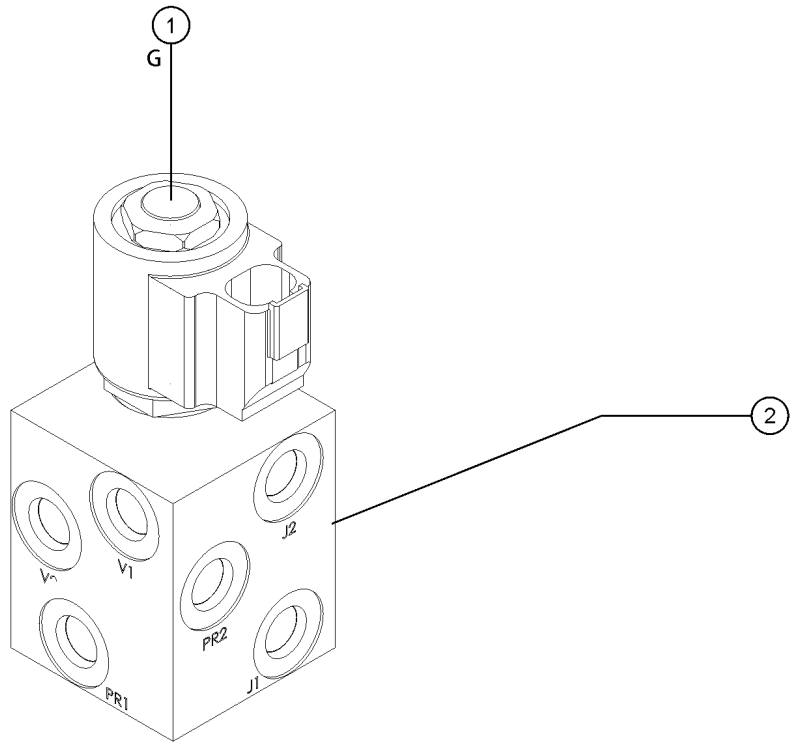

Jib Manifold

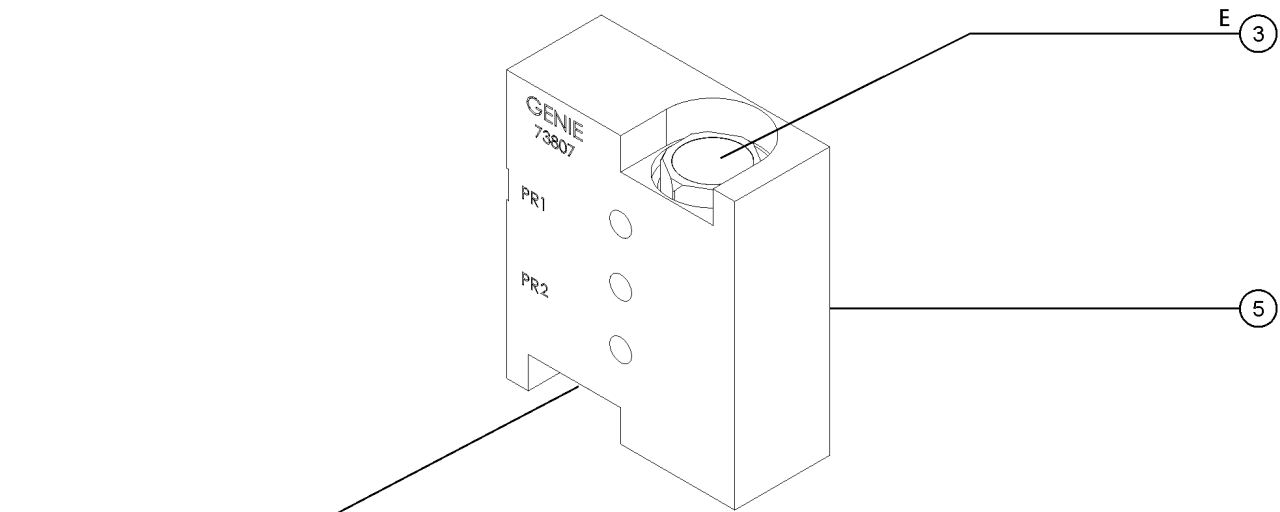

Platform Rotate Manifold

603.1 Jib Boom and Platform Rotate Manifolds

Item	Part No.	Description	Qty.
1A	89862GT	VALVE-SOLENOID,2POS 3WAY,JIB** (G, Jib boom / platform rotate select) (to SN 15A-54807) (for 94859GT, check PN on jib manifold before ordering)	
--	77709GT	COIL,#8 20VDC,DEUTSCH W/DIOD (to SN 15A-54807)	
--	89864GT	SEAL KIT,SOLENOID VALVE, SV07 (to SN 15A-54807)	
1B	52897GT	VALVE,SOLENOID, 2POS/3WAY*** (from SN 15A-54808) (for 1267570GT, check PN on jib manifold before ordering)	
--	44174GT	NUT-COIL SHORT (from SN 15A-54808)	
--	52371GT	SEAL KIT, VALVE (from SN 15A-54808)	
--	77709GT	COIL,#8 20VDC,DEUTSCH W/DIOD (from SN 15A-54808)	
2B	1267570GT	MANIFOLD,JIB SELECT,20V***	
3	62506GT	VALVE - COUNTERBALANCE** E, Platform Rotate Right Circuit	
--	43018GT	SEAL KIT (39345)	
4	62506GT	VALVE - COUNTERBALANCE** F, Platform Rotate Left Circuit	
--	43018GT	SEAL KIT (39345)	
5	73807GT	MANIFOLD,ROTATOR,CB***	
--	62507GT	O-RING, ROTATOR MANIFOLD Manifold to Platform Rotator	

701.1 Drive and Steer Hoses

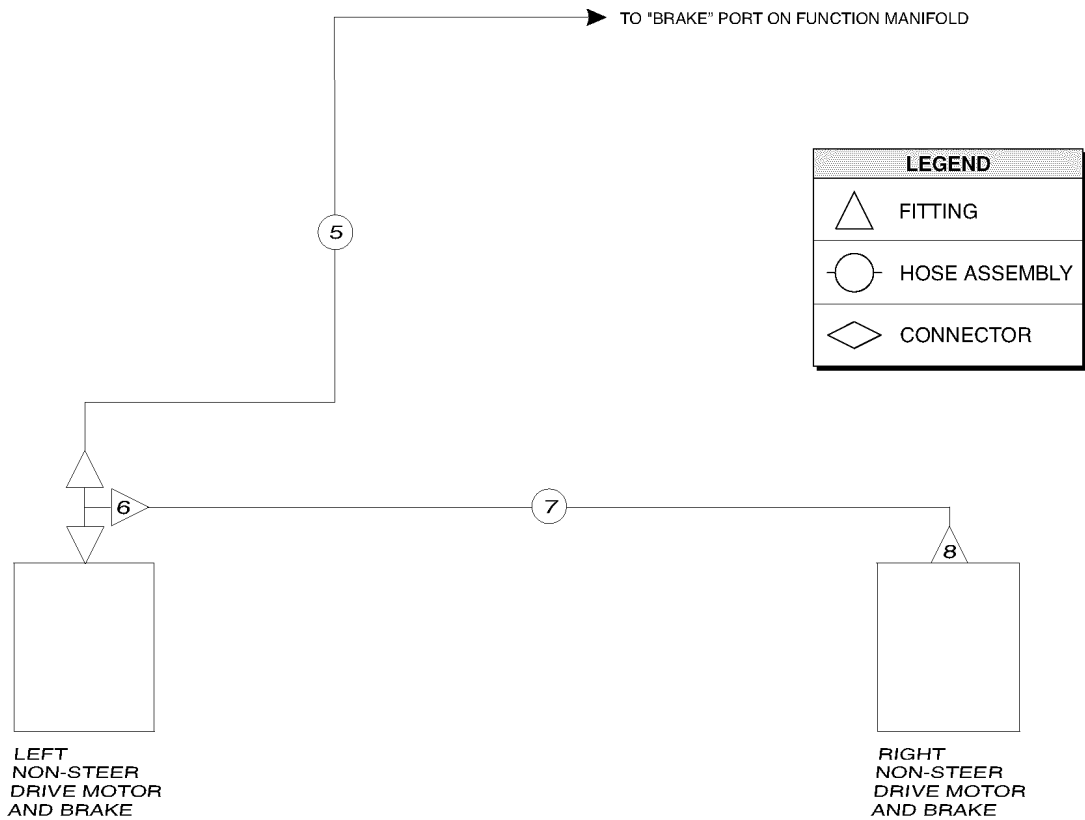
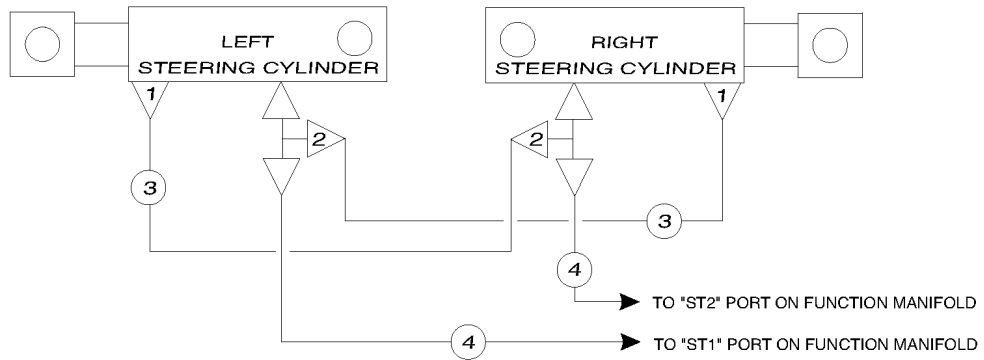

701.1 Drive and Steer Hoses

Item	Part No.	Description	Qty.
--	28750GT	O-RING KIT,FIELD SVC,ALL PROD*	
--	33994GT	PLUG AND CAP KIT-SERVICE,37 **	
--	49612GT	O-RING KIT (ORFS FITTINGS)	
--	49613GT	PLUG AND CAP KIT-SERVICE,ORFS*	
1	48904GT	ELBOW,90D,520220-4-4.....2	
2	48906GT	TEE,RUN,520428-4.....2	
3	49119-2078GT	HOSE ASSY,1/4,STR FEM,STR FEM*2	
4	49117-11091GT	HOSE ASSY,1/4,90 FEM,STR FEM.....2	
5	49117-9991GT	HOSE ASSY,1/4,90 FEM,STR FEM.....1	
6	48890GT	FITTING,TEE,BRANCH,520429-4***1	
7	49117-4691GT	HOSE ASSY,1/4,90 FEM,STR FEM.....1	
8	48904GT	ELBOW,90D,520220-4-4.....1	

702.1 Turntable Components

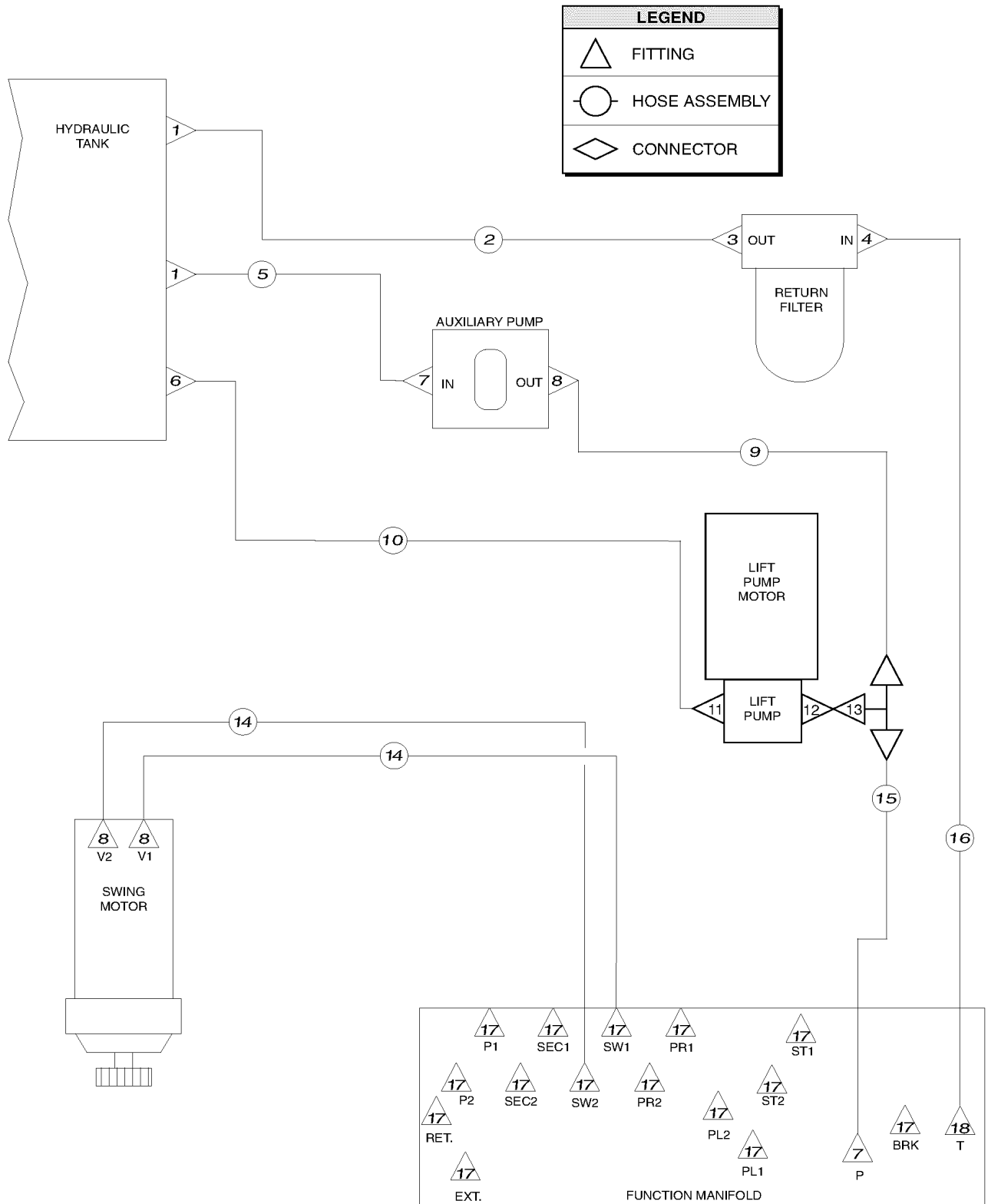

702.1 Turntable Components

Item	Part No.	Description	Qty.
--	28750GT	O-RING KIT,FIELD SVC,ALL PROD*	
--	33994GT	PLUG AND CAP KIT-SERVICE,37 **	
--	49612GT	O-RING KIT (ORFS FITTINGS)	
--	49613GT	PLUG AND CAP KIT-SERVICE,ORFS*	
1	48944GT	CONN,520102-8-8.....	2
2	49143-2535GT	HOSE ASSY,1/2,90 FEM,STR FEM.....	1
3	48947GT	ELBOW,90D,520220-8-12.....	1
4	48948GT	CONN,520120-8-12.....	1
5	77059-2986GT	HOSE ASSY,MULTI USE***	1
6	45162GT	STRAINER ASSEMBLY,1.25" NPT*** from SN 27000	
7	48916GT	CONN, 520120-6.....	2
8	48911GT	ELBOW,90D,520220-4-6***	3
9A	49164-2043GT	HOSE ASSY 1/4,90 DEG FEM,STR F....1 to SN 40593	
9B	T115351GT	HOSE ASSY,1/4,STR FEM,STR FEM from SN 40594	
10A	77059-4086GT	HOSE ASSY,LIFT PUMP/F.MANIF***	1
		to SN 40593	
10B	232574GT	HOSE ASSY, 3/4, 90D, STR FEM from SN 40594 to 44811	
10C	1270353GT	HOSE ASSY, 3/4, 90 FEM, 45 FEM DC only from SN Z452512A-44812	
10D	232574GT	HOSE ASSY, 3/4, 90D, STR FEM BE only from SN Z452512A-44812	
11	48975GT	CONN,520120-12-10.....	1
12	48999GT	VALVE,CHK,#8PORT-#8MALEORFS.....	1
13	48939GT	TEE,BRANCH,520433-8.....	1
14	49119-3378GT	HOSE ASSY,1/4,STR FEM,STR FEM.....	2
15A	77059-2986GT	HOSE ASSY,MULTI USE***	1
		to SN Z452512A-44811	
15C	214814GT	HOSE ASSY, 1/2, 39.25 DC only from SN Z452512A-44812	
15D	214816GT	HOSE ASSY, 1/2, 20.75 BE only from SN Z452512A-44812	
16	49143-2029GT	HOSE ASSY,1/2,90 FEM,STR FEMM*....	1
17	48912GT	CONN,520120-4-6***	15
18	48942GT	ELBOW,90D,520220-8-6.....	1

Item	Part No.	Description	Qty.
--	28678GT	SLEEVE,NYLON,2" I.D.,BULK(100').18-inches <i>protective hose sleeve, 2.00" diameter</i>	
--	28750GT	O-RING KIT,FIELD SVC,ALL PROD*	
--	33994GT	PLUG AND CAP KIT-SERVICE,37 **	
--	48767GT	SLEEVE,NYLON,1.42 ID.....25-inches <i>protective hose sleeve, 1.42" diameter</i>	
--	49612GT	O-RING KIT (ORFS FITTINGS)	
--	49613GT	PLUG AND CAP KIT-SERVICE,ORFS*	
--	77103GT	SLEEVE,NYLON,3.13 ID.....27-inches <i>protective hose sleeve, 3.13" diameter</i>	
1	48904GT	ELBOW,90D,520220-4-4.....	2
2A	49119-27978GT	HOSE ASSY,1/4,STR FEM,STR FEMM..... <i>to SN Z452512A-44811</i>	2
2B	49121-25688GT	HOSE ASSY 1/4,STR FEM,STR MALE <i>from SN Z452512A-44812</i>	
3	48912GT	CONN,520120-4-6***.....	21
4	48917GT	CONN,LONG,520122-6.....	2
5A	49119-26078GT	HOSE ASSY,1/4,STR FEM,STR FEM..... <i>to SN 38910</i>	1
5B	49119-26078GT	HOSE ASSY,1/4,STR FEM,STR FEM <i>from SN 38911</i>	
6A	49119-27478GT	HOSE ASSY,1/4,STR FEM,STR FEM..... <i>to SN 38910</i>	1
6B	49119-27478GT	HOSE ASSY,1/4,STR FEM,STR FEM <i>from SN 38911</i>	
7	48919GT	TEE,BRANCH,520429-6.....	2
8	49120-33381GT	HOSE ASSY 1/4, STR FEM,STR FEM....	2
9A	49119-2078GT	HOSE ASSY,1/4,STR FEM,STR FEM*.... <i>to SN 38910</i>	2
9B	49119-2278GT	HOSE ASSY,1/4,STR FEM,STR FEM <i>from SN 38911 to 44811</i>	
9C	49119-2178GT	HOSE ASSY,1/4,STR FEM,STR FEM <i>from SN Z452512A-44812</i>	
10A	49119-37978GT	HOSE ASSY 1/4,STR FEM,STR FEM..... <i>to SN 38910</i>	2
10B	49119-39378GT	HOSE ASSY,1/4,STR FEM,STR FEM <i>from SN 38911</i>	
11	49119-34378GT	HOSE ASSY 1/4, STR FEM,STR FEM....	1
12	48916GT	CONN, 520120-6.....	5
13	48923GT	PLUG,090109A-6.....	2
14	49119-13978GT	HOSE ASSY,1/4,STR FEM,STR FEM.....	2
15	49119-36378GT	HOSE ASSY,1/4,STR FEM,STR FEM.....	2
16	49119-35678GT	HOSE ASSY,1/4,STR FEM,STR FEM.....	1
17		Ref. Hose Assembly (refer to 801.1)	
18	48942GT	ELBOW,90D,520220-8-6.....	1

704.1 Boom Components - Z-45/25J

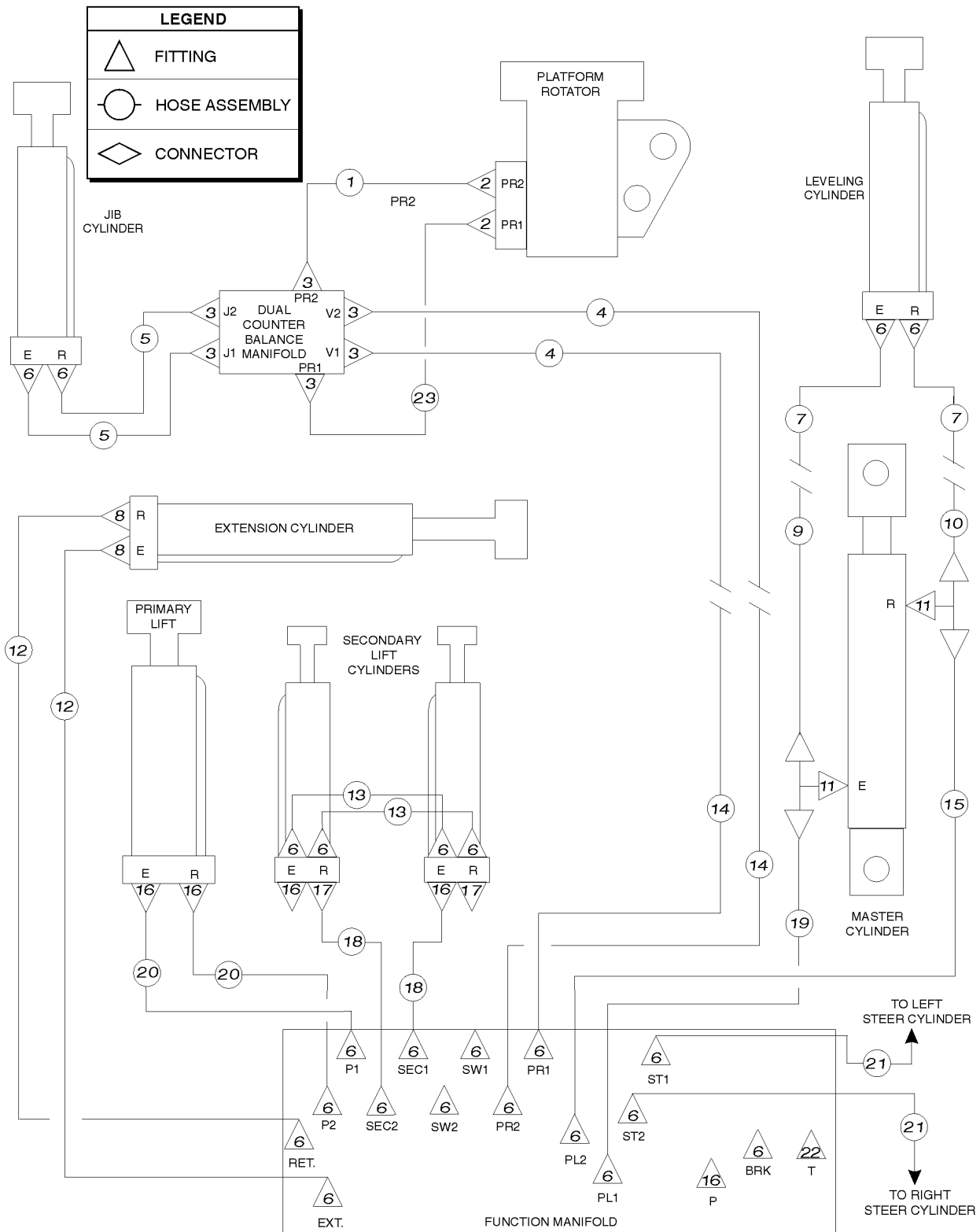

Item	Part No.	Description	Qty.
--	28678-2250GT	SLEEVE,NYLON, 2" ID	
--	28750GT	O-RING KIT,FIELD SVC,ALL PROD*	
--	33994GT	PLUG AND CAP KIT-SERVICE,37 **	
--	48767-700GT	SLEEVE,NYLON,1.42 ID	
--	49612GT	O-RING KIT (ORFS FITTINGS)	
--	49613GT	PLUG AND CAP KIT-SERVICE,ORFS*	
1A	49119-2078GT	HOSE ASSY,1/4,STR FEM,STR FEM*....1 <i>to SN 38910</i>	
1B	139099GT	HOSE ASSY, 1/4", 22.00 <i>from SN 38911</i>	
2	48904GT	ELBOW,90D,520220-4-4.....2	
3	48905GT	CONN,520120-4***.....5	
4	49121-27788GT	HOSE ASSY 1/4,STR FEM,STR MALE..2	
5	49119-4178GT	HOSE ASSY,1/4,STR FEM,STR FEM....2	
6	48912GT	CONN,520120-4-6***.....23	
7	49121-2088GT	HOSE ASSY 1/4,STR FEM,STR MALE..2	
8	48917GT	CONN,LONG,520122-6.....2	
9	49119-20578GT	HOSE ASSY,1/4,STR FEM,STR FEM....1	
10	49119-21878GT	HOSE ASSY,1/4,STR FEM,STR FEM....1	
11	48919GT	TEE,BRANCH,520429-6.....2	
12	49120-33381GT	HOSE ASSY 1/4, STR FEM,STR FEM....2	
13A	49119-2078GT	HOSE ASSY,1/4,STR FEM,STR FEM*....2 <i>to SN 38910</i>	
13B	49119-2278GT	HOSE ASSY,1/4,STR FEM,STR FEM <i>from SN 38911</i>	
14	49119-37978GT	HOSE ASSY 1/4,STR FEM,STR FEM....2	
15	49119-34378GT	HOSE ASSY 1/4, STR FEM,STR FEM....1	
16	48923GT	PLUG,090109A-6.....4	
17	48916GT	CONN, 520120-6.....1	
18A	49119-16178GT	HOSE ASSY,1/4,STR FEM,STR FEM....2 <i>to SN 38910</i>	
18B	49119-13978GT	HOSE ASSY,1/4,STR FEM,STR FEM <i>from SN 38911</i>	
19	49119-35678GT	HOSE ASSY,1/4,STR FEM,STR FEM....1	
20	49119-36378GT	HOSE ASSY,1/4,STR FEM,STR FEM....2	
21	49117-11091GT	HOSE ASSY,1/4,90 FEM,STR FEM.....1	
22	48942GT	ELBOW,90D,520220-8-6.....1	
23A	49119-2078GT	HOSE ASSY,1/4,STR FEM,STR FEM*....1 <i>to SN 38910</i>	
23B	139099GT	HOSE ASSY, 1/4", 22.00 <i>from SN 38911 to 44811</i>	
23C	232575GT	HOSE ASSY, 1/4", 21.24" <i>from Z452512A-48812</i>	

801.1 Flashing Beacon

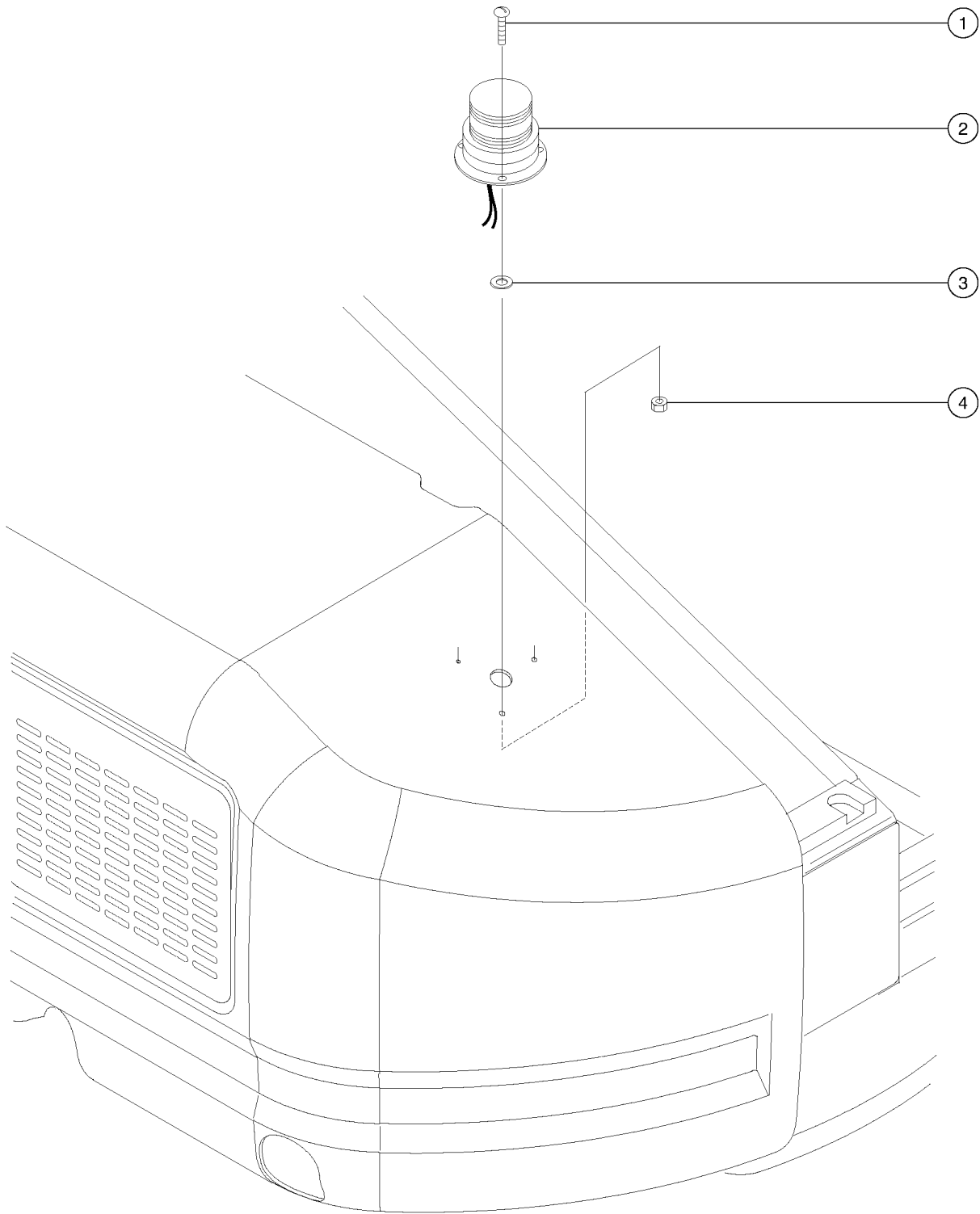

801.1 Flashing Beacon

Item	Part No.	Description	Qty.
1	49821GT	SCREW,PHILLIPS,PHM,8-32 X 1.25	
2	56704GT	STROBE,FIREBOLT,12-80VDC,AMB**...1 <i>(replaced 20189)</i>	
--	122019GT	FLASHTUBE,U SHAPED,360DEG,BULB	
--	226393GT	FLASHTUBE,STRAIGHT,360DEG,BULB	
--	72282GT	LENS,AMBER,STROBE,FIREBOLT	
3	35461GT	WASHER,FLAT,MS,#8,Y	
4	18605GT	NUT,NYLOCK,8-32	

802.1 Platform Options

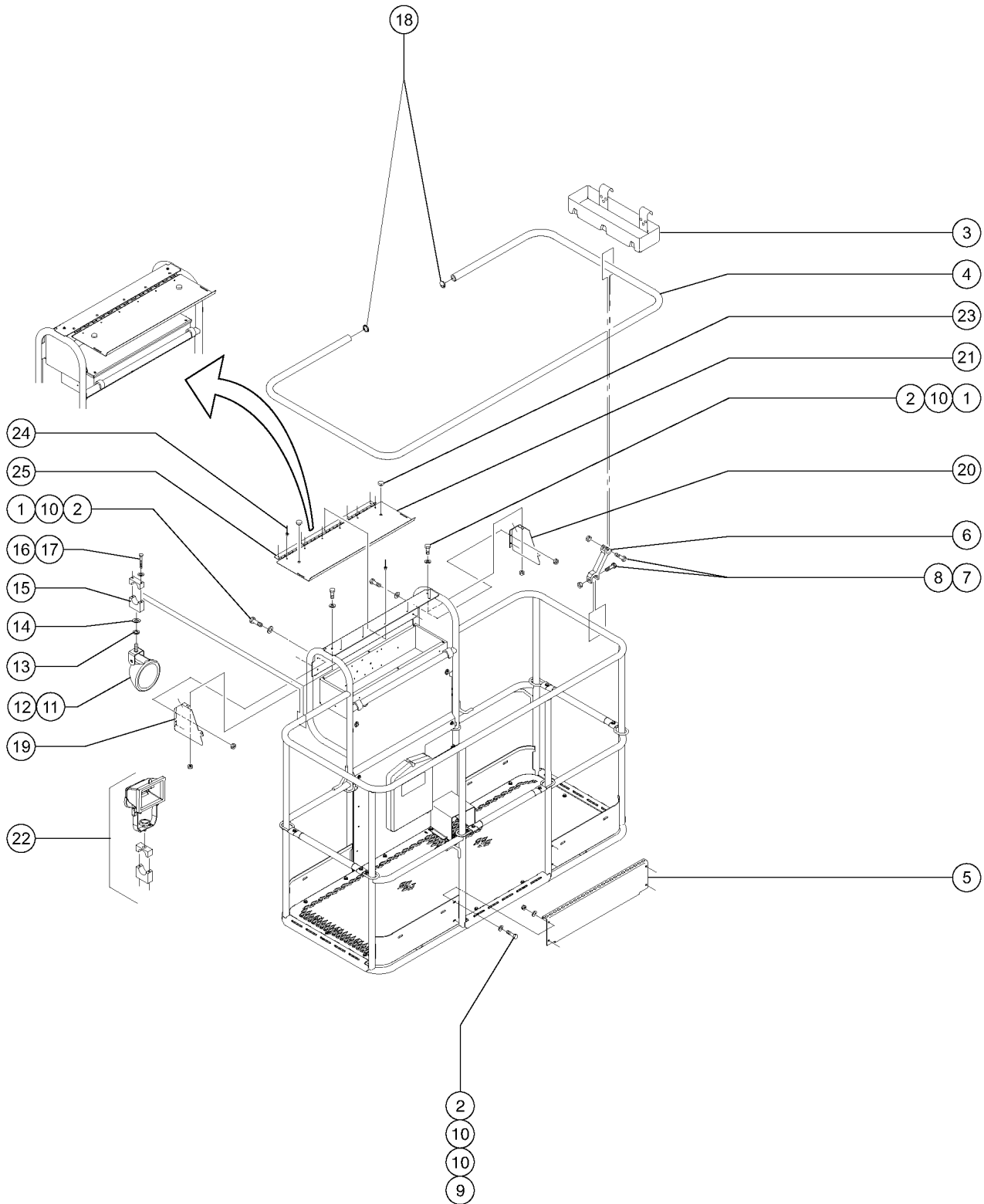

802.1 Platform Options

Item	Part No.	Description	Qty.	Item	Part No.	Description	Qty.
--	122278GT	AUX TOP RAIL,6',SWG GT, SRV		20	88606PGT	COVER,CONTROL BOX RIGHT SIDE**.....	1
--	122279GT	AUX TOP RAIL,8',SWG GT, SRV		21	102785PGT	CONTROL BOX COVER,LID,PTD.....	1
--	28322GT	OPTION,PLAT.PINCH GUARD,5 FT.		--	102786PGT	FORMING,LATCH,CTRL BOX LID PTD.....	2
--	28323GT	OPTION,PLAT.PINCH GUARD,4 FT.				(not included - sold seperately)	
--	53157-SGT	PINCH GUARD,6'(1.31")SERVICE**		--	30468GT	LATCH,SLIDE, FLUSH MOUNT STYLE.....	2
--	53807-SGT	AUX TOP RAIL,8'(1.25")SERVICE				(not included - sold seperately)	
--	53808-SGT	AUX TOP RAIL,6'(1.25")SERVICE		--	43392GT	BUMPER,BATTERY BOX & RAILS.....	2
--	60922GT	OPTION,EURO TOEBOARD <i>includes item 5</i>		--	88606PGT	COVER,CONTROL BOX RIGHT SIDE**.....	1
--	88609-SGT	CONTROL BOX COVER ASSY*** <i>includes mounting fasteners</i>		--	88607PGT	COVER,CONTROL BOX LEFT SIDE***.....	1
1	7339GT	SCREW,HHC,1/4-20 X .5				(not included - sold seperately)	
2	6091GT	NUT,NYLOCK,1/4-20		22	1284764GT	WORKLIGHT,110V,250WATT,HALOGEN.	2
3	9599-SGT	TOOL TRAY ACCESSORY***.....	1	23	34619GT	BUMPER,RUBBER***.....	2
--	7746GT	BRACKET-TOOL TRAY MOUNTING.....	2	24	54486GT	RIVET,ALUM,ALUM,3/16BUTTONHEAD	
4	28329GT	RAILING,PINCH GAURD,4 FT.....	1	25	111526GT	HINGE,PLAT CONTROL BOX COVER...1	
--	28328GT	RAILING,PINCH GAURD,5 FT.					
5	94745PGT	TOEBOARD,ENTRY EUROPEAN PNTD**.....	1				
6	139958GT	KIT, AUX TOP RAIL SUPPORT.....	10				
		<i>to SN 34908</i>					
--	122073GT	SUPPORT, RAILING.....	20				
		<i>from SN 34909</i>					
7	4266GT	SCREW,HHC,1/4-20 X 2 <i>to SN 34908</i>					
--	122231GT	SCREW,BHSC,1/4-20 X 1 <i>from SN 34909</i>					
8	6889GT	NUT,LP NYLOCK,1/4-20					
9	8914GT	SCREW,HHC,1/4-20 X .625					
10	6638GT	WASHER,FLAT,USS,1/4"Y					
11A	107857GT	LIGHT, 12 VOLT.....	2				
--		REF: Harness, Z45 Drive Lights.....	1				
		<i>refer to 410.1, 411.1 or 412.1</i>					
--	35960GT	BULB,WORKLIGHT,12V 35W					
11B	107858GT	WORKLIGHT,48 VOLT					
--		REF: Harness, Z45 Drive Lights.....	1				
		<i>refer to 410.1, 411.1 or 412.1</i>					
12	13002GT	SCREW,HHC,5/16-18 X 1 GR5					
13	6886GT	WASHER,LOCK, .313					
14	5397GT	WASHER,FLAT,USS,5/16", Y					
15	35956GT	BRACKET,WORK LIGHT MOUNT 5/16".....	2				
16	6145GT	SCREW,HHC,1/4-20 X 1.5					
17	6356GT	WASHER,LOCK, .25					
18	55753GT	BUMPER, PLASTIC, 1.25 O.D.....	2				
19	88607PGT	COVER,CONTROL BOX LEFT SIDE***.....	1				



803.1 Half-height mesh and Swing Gate Options

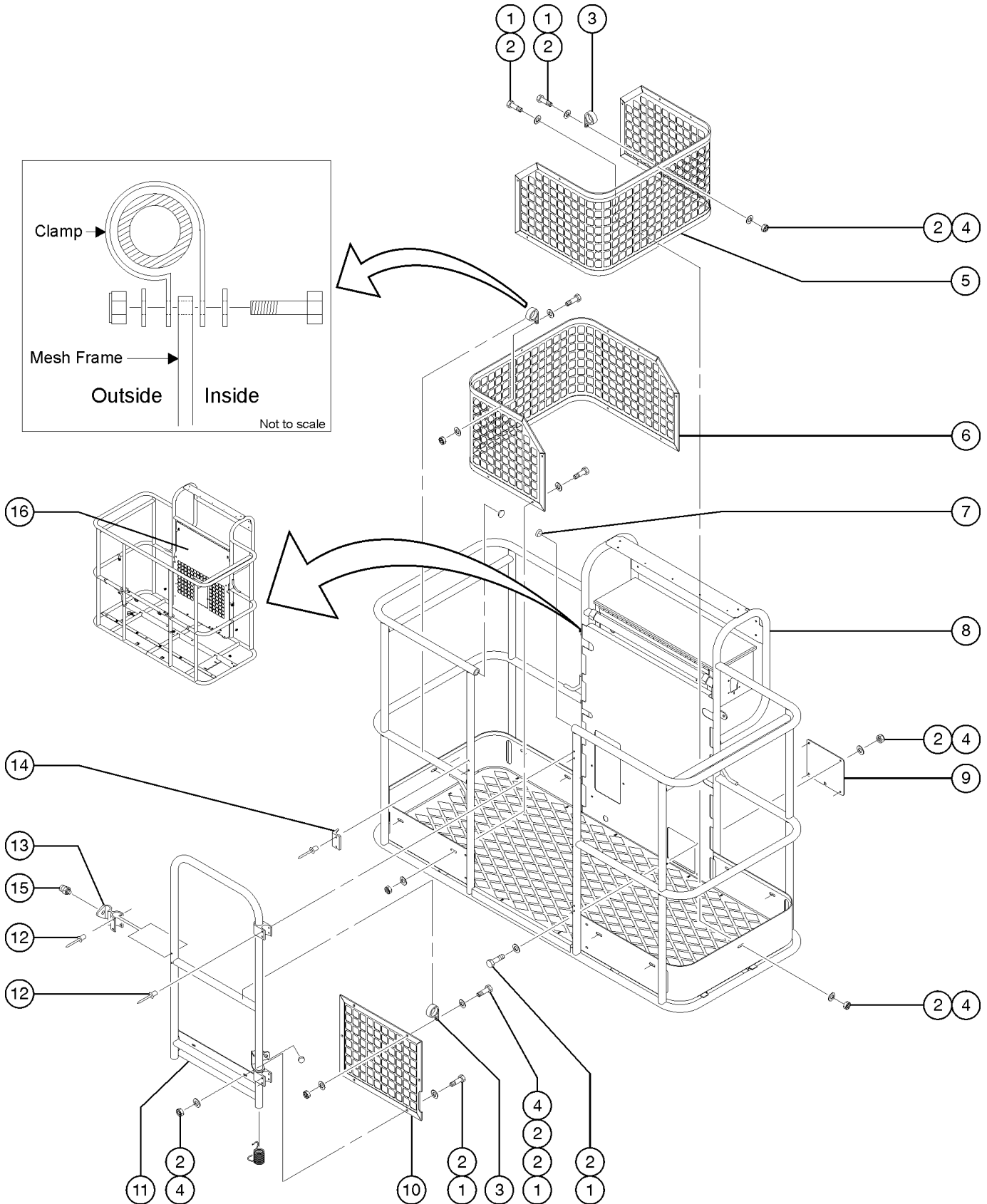

803.1 Half-height mesh and Swing Gate Options

Item	Part No.	Description	Qty.
1	8914GT	SCREW,HHC,1/4-20 X .625	
2	6638GT	WASHER,FLAT,USS,1/4"Y	
3	54932GT	CLAMP,1.25,#20 X 1/4,RUB CUSH	
4	6091GT	NUT,NYLOCK,1/4-20	
5	54458GT	MESH,HALF,LH,6'PLATFORM.....1	
--	101852GT	MESH,HALF,LH 5' PLATFORM	
6	54465GT	MESH,HALF,RH,6'PLATFORM.....1	
--	101853GT	MESH,HALF,RH 5' PLATFORM	
7	55753GT	BUMPER, PLASTIC, 1.25 O.D.....2	
8	52752-SGT	PLATFORM,1/2 MESH W/GATE,ANSI*.....1 <i>ANSI and CSA</i>	
--	52753-SGT	PLAT.ASSY,6FT,1/2 MESH, CE CE	
9	54165GT	PLATE,FOOT SWITCH COVER.....1	
10	54457GT	MESH,HALF,SWING GATE***.....1	
11	128368GT	KIT,SWING GATE W/SPRING	
--	128374GT	WELDMENT,SWING GATE,ALUMINUM	
--	42104GT	SPRING,SHORT PLATFORM GATE	
--	43392GT	BUMPER,BATTERY BOX & RAILS	
11A	119950GT	KIT,FIELD INSTALL,SWING GATE <i>includes 128368, 1487, 1488 and 33674</i>	
12	7265GT	RIVET,STEEL,P, .25 X .375	
13	1487GT	GATE LATCH CASTING--DRILLED	
14	1488GT	RAILING CATCH CASTING--DRILLED	
15	33674GT	PIN,LOCK,SHORT***	
16	73901GT	DECAL PLATE,MESH.....1	

804.1 Air Line to Platform

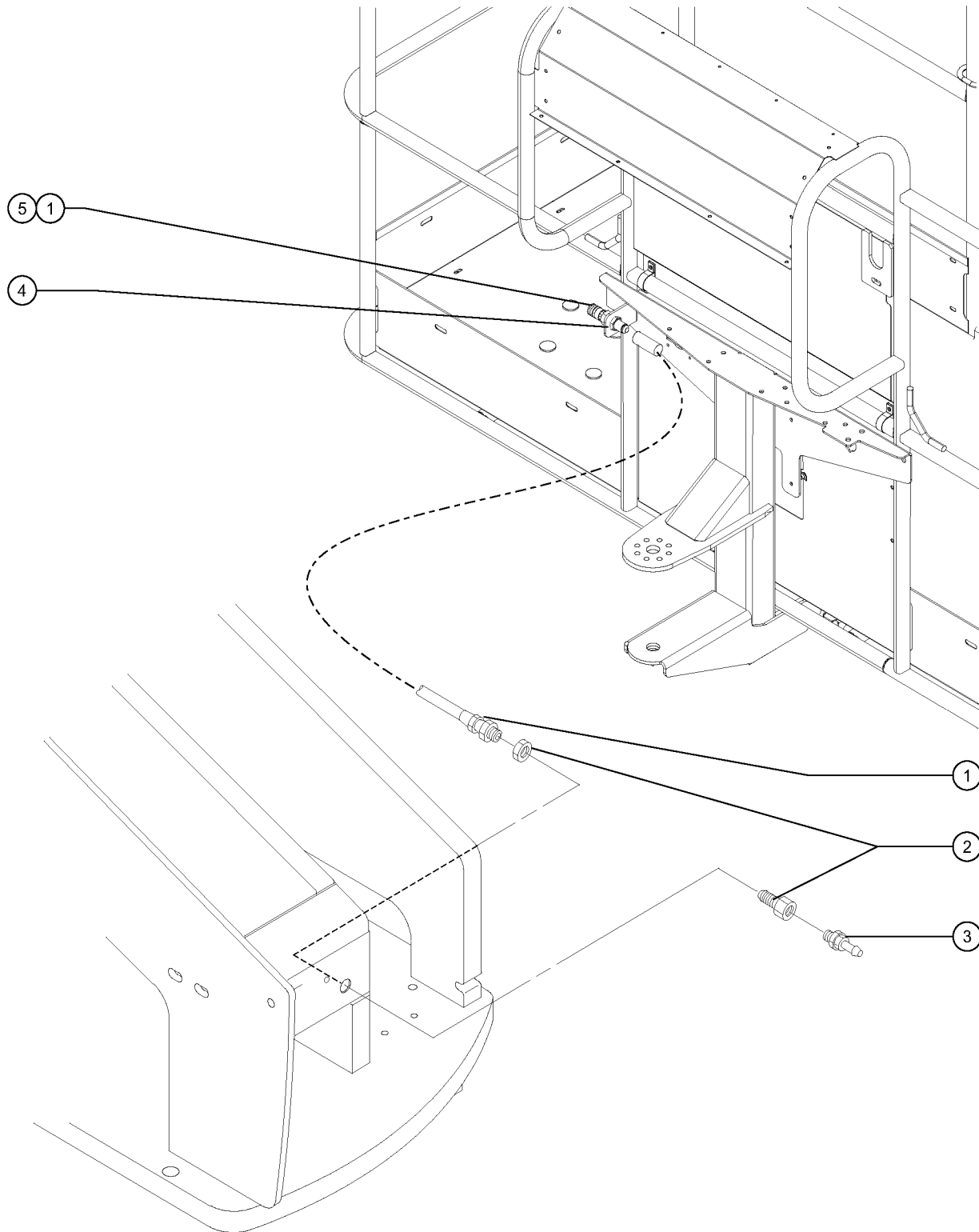

804.1 Air Line to Platform

Item	Part No.	Description	Qty.
1	70644-75792GT	HOSE ASSY,3/8 STR FEM STR FEM*....1	
--	16073GT	CLAMP,0.63,#10 X 1/4,RUB CUSH	
2	49212GT	FEMALE BULKHEAD CONNECTOR-8...2	
3	49214GT	MALE PIPE THD,1/4" SER,3/8"X18.....1	
4	70642PGT	BRACKET,AIR HOSE TO PLAT PAINT....1	
5	49215GT	MPT,CPLR,1/4"SER,3/8"X18.....1	

805.1 Platform Overload Option

Item	Part No.	Description	Qty.
--	147509GT	KIT,LOAD SENSE MECH,Z45 JIB <i>(from SN Z4510A-39314 and from SN Z4510B-1488)</i>	
--	128045GT	MODULE,LOAD SENSE 2007	
2	4266GT	SCREW,HHC,1/4-20 X 2	
3	6091GT	NUT,NYLOCK,1/4-20	
4	94492PGT	PANEL,ACCESS PAINTED.....1	
5	6090GT	SCREW,HHC,1/4-20 X .75	
6	6638GT	WASHER,FLAT,USS,1/4"Y	
7	56912GT	SPRING CLIP,1/4-20,.025-.15X.54,ZAG	
8	61998GT	WELDMENT,PLATFORM SUPPORT.....1 <i>jib models with platform overload option</i>	
9	6888GT	SCREW,HHC,1/4-20 X 1	
10	45748GT	ROD END,.250 X 2.75 LG	
11	61726GT	PIN,0.75DIAX5.75LG,CHAMFER.....4	
--	94643GT	ZERK,GREASE,5/16-24,STRAIT	
12	25685GT	BEARING,GARLOCK,12FDU12.....4	
13	73634GT	SCREW,PHIL,PHM,10-24X1.5 ZINC	
14	6146GT	WASHER,FLAT,MS,#10,Y	
15	4828GT	NUT,NYLOCK,3/8-16	
16	61975GT	RETAINER,SPRING,1.21 X .375	
17	61974GT	SPRING,COMP,1" OD,232 LB/IN	
18	101512GT	LOAD SUPPORT WITH BEARINGS.....1 <i>includes item 12</i>	
19C	94549GT	SWITCH,LOAD LIMIT <i>(to SN Z452510A-39313) Z-45/25J</i>	
19D	121848GT	ASSY,LS,LOAD SENSE,38.5 IN <i>(from SN Z452510A-39314) Z-45/25J</i>	
20	6097GT	WASHER,FLAT,USS,3/8",Y	
21	61972GT	MOUNT,SWITCH.....1	
22	34619GT	BUMPER,RUBBER***.....2	
23	15086GT	WASHER,FLAT,.375 X 1.5 X .125	
24	21604GT	SCREW,HHC,3/8-16 X 3.25	
25	61987GT	WELDMENT,ROTATOR MOUNT.....1	
27	110789GT	WASHER,SHIM .0151 THK.....as-needed	
28	5365GT	NUT,NYLOCK,10-24	

806.1 Hostile Environment Package - View 1

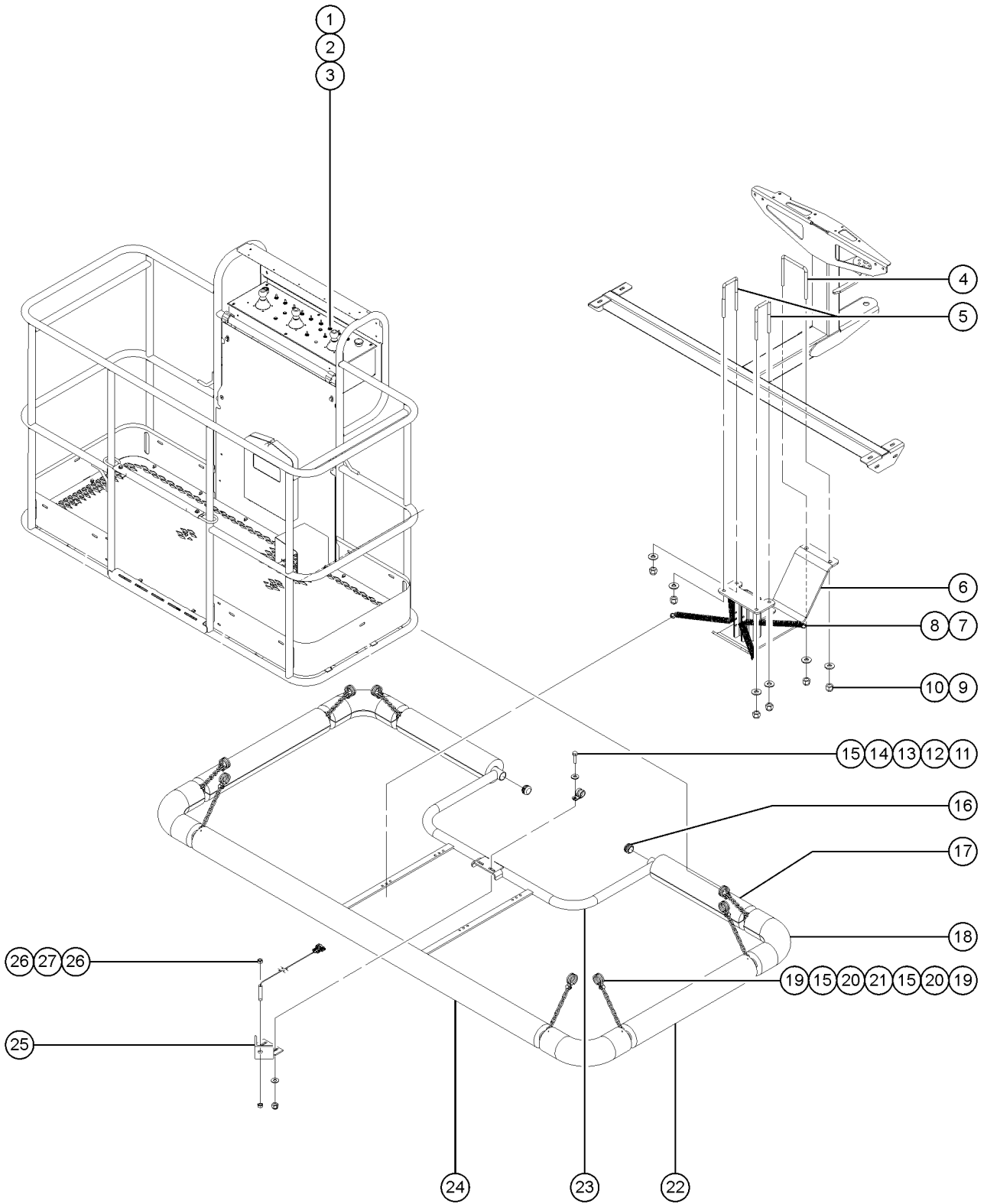

806.1 Hostile Environment Package - View 1

Item	Part No.	Description	Qty.
--	54883GT	BELLOWS,CYL.KIT,Z45&Z51 JIB	
1B	54638GT	BELLOWS,PRIMARY CYLINDER,JIB.....1	
2	54640GT	BELLOWS,MASTER CYLINDER.....1	
3	54989GT	BELLOWS,STEERING CYLINDER.....1	
4	54652GT	BELLOWS,SECONDARY,ELEVATE CYL.....1	
5	54639GT	BELLOWS,SLAVE CYLINDER.....1	
6	54635GT	BELLOWS,JIB CYLINDER.....1 Z-45/25J	

807.1 Hostile Environment Package - View 2

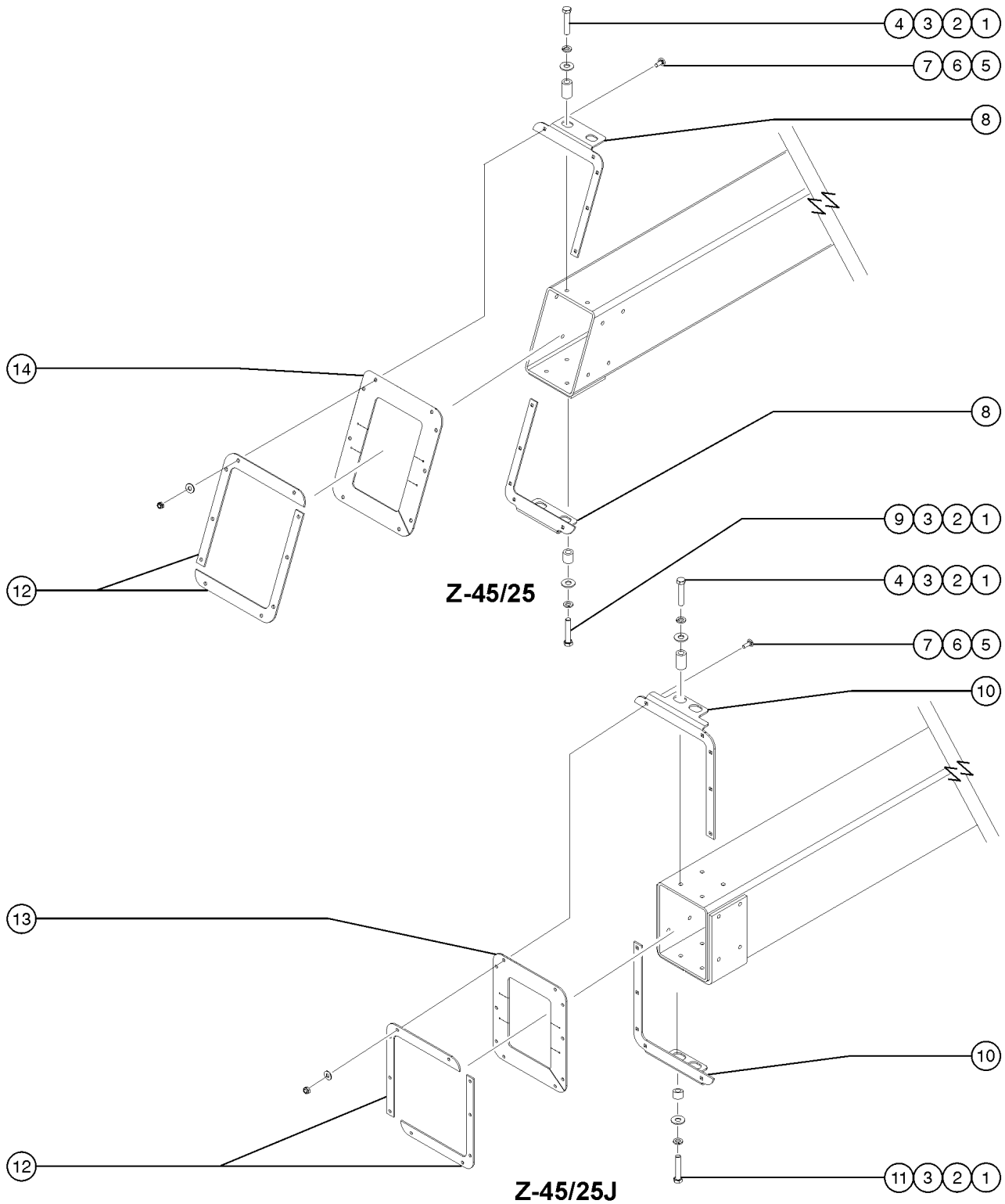

Z-45/25

Z-45/25J

807.1 Hostile Environment Package - View 2

Item	Part No.	Description	Qty.
--	147184GT	KIT, WIPER, Z-45/25J	
1	5224GT	SCREW,HHC,3/8-16 X 2	
2	6021GT	WASHER,LOCK,.375	
3	6097GT	WASHER,FLAT,USS,3/8",Y	
4	128852GT	TUBE,RD,STL,DOM,.75X.438X1.25.....2	
5	6878GT	BOLT,CARRIAGE,1/4-20 X .75,G2	
6	6021GT	WASHER,LOCK,.375	
7	6889GT	NUT,LP NYLOCK,1/4-20	
10	147041GT	FORMING WIPER MOUNT.....2	
11	45400GT	SPACER TUBE,.50 LG.....2	
12	128973GT	PLATE,WIPER BACKING.....2	
13	147181GT	WIPER,PRIMARY BOOM.....1	

808.1 Drive Lights

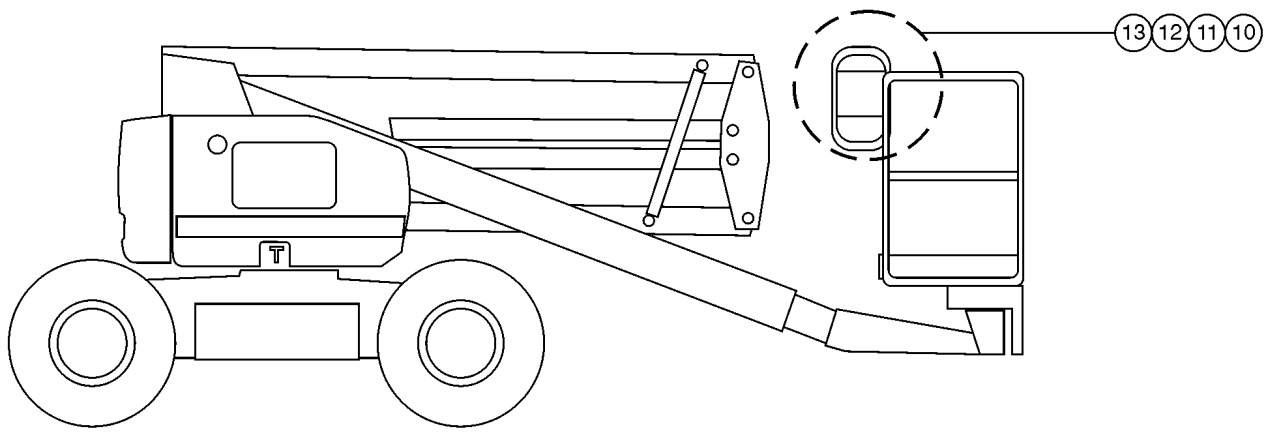
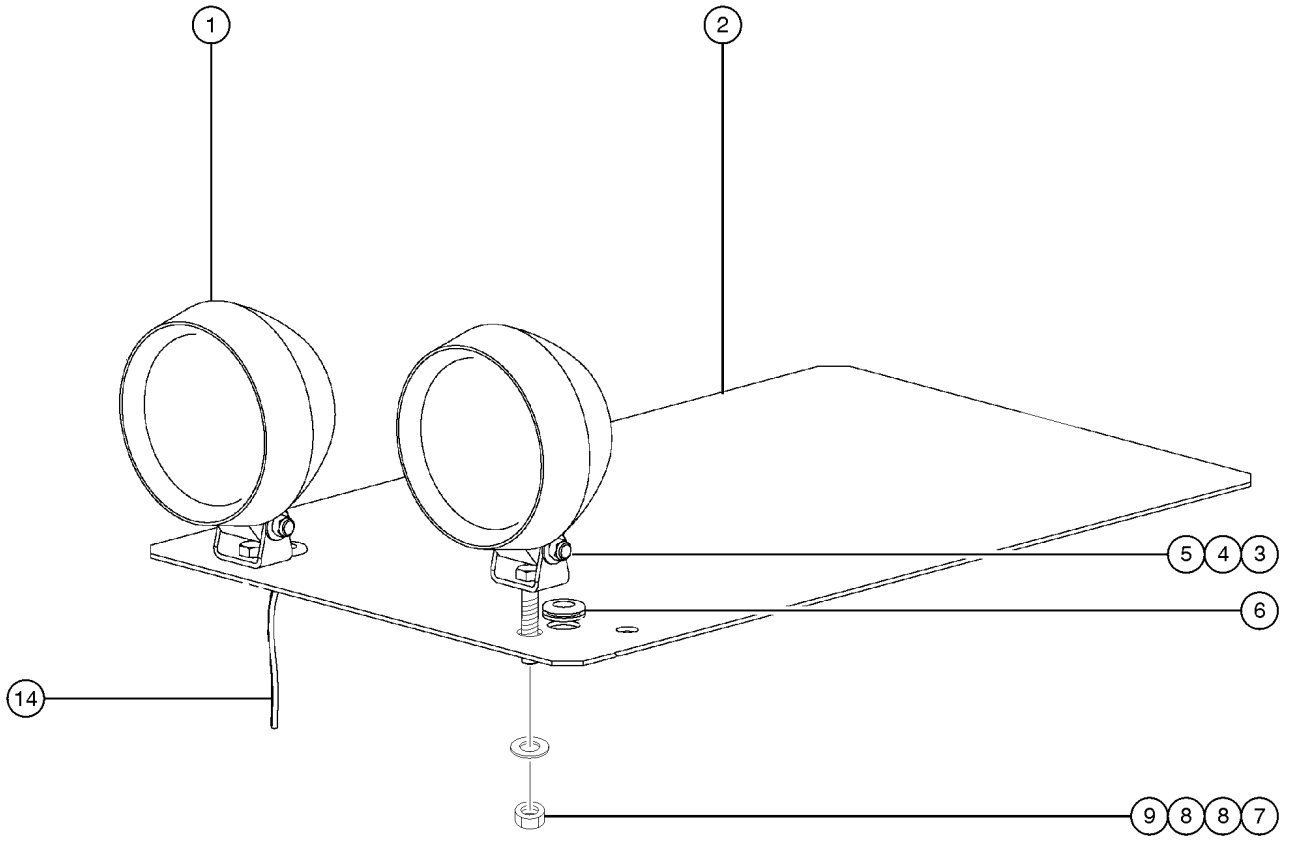

808.1 Drive Lights

Item	Part No.	Description	Qty.
1	107858GT	WORKLIGHT,48 VOLT.....2 <i>includes items 3-5 and 7-9</i>	
2	128956GT	COVER, DRIVE, DRIVE LIGHT OPT.....1	
3	10107GT	SCREW,HHC,5/16-18 X .75.....2	
4	5397GT	WASHER,FLAT,USS,5/16",Y.....2	
5	6782GT	NUT,NYLOCK,5/16-18.....2	
6	53517GT	GROMMET,RUBBER .5 X .014 X .75....2	
7	4828GT	NUT,NYLOCK,3/8-16.....2	
8	5397GT	WASHER,FLAT,USS,5/16",Y.....4	
9	6175GT	SCREW,HHC,3/8-16 X 1.....2	
10	823226GT	POWER RELAY, 24V COIL.....1	
--	54365GT	SCREW,PHIL,PHM,10-32 X .5,SSTL....1	
--	6146GT	WASHER,FLAT,MS,#10,Y.....2	
--	6178GT	NUT,NYLOCK,10-32.....1	
11	72867GT	DECAL,LABEL,LIGHTS***.....1	
12	128204GT	SWITCH TOGGLE ASSY SPDT 2P MNT.....1	
--	27246GT	BOOT,TOGGLE SWITCH,SHORT*.....1	
13	6578GT	CABLE TIE,7 3/8".....5	
14		REF: Harness, Z45 Drive Lights.....1 <i>refer to 410.1, 411.1 or 412.1</i>	

809.1 Traveling Fall Arrest Anchor System

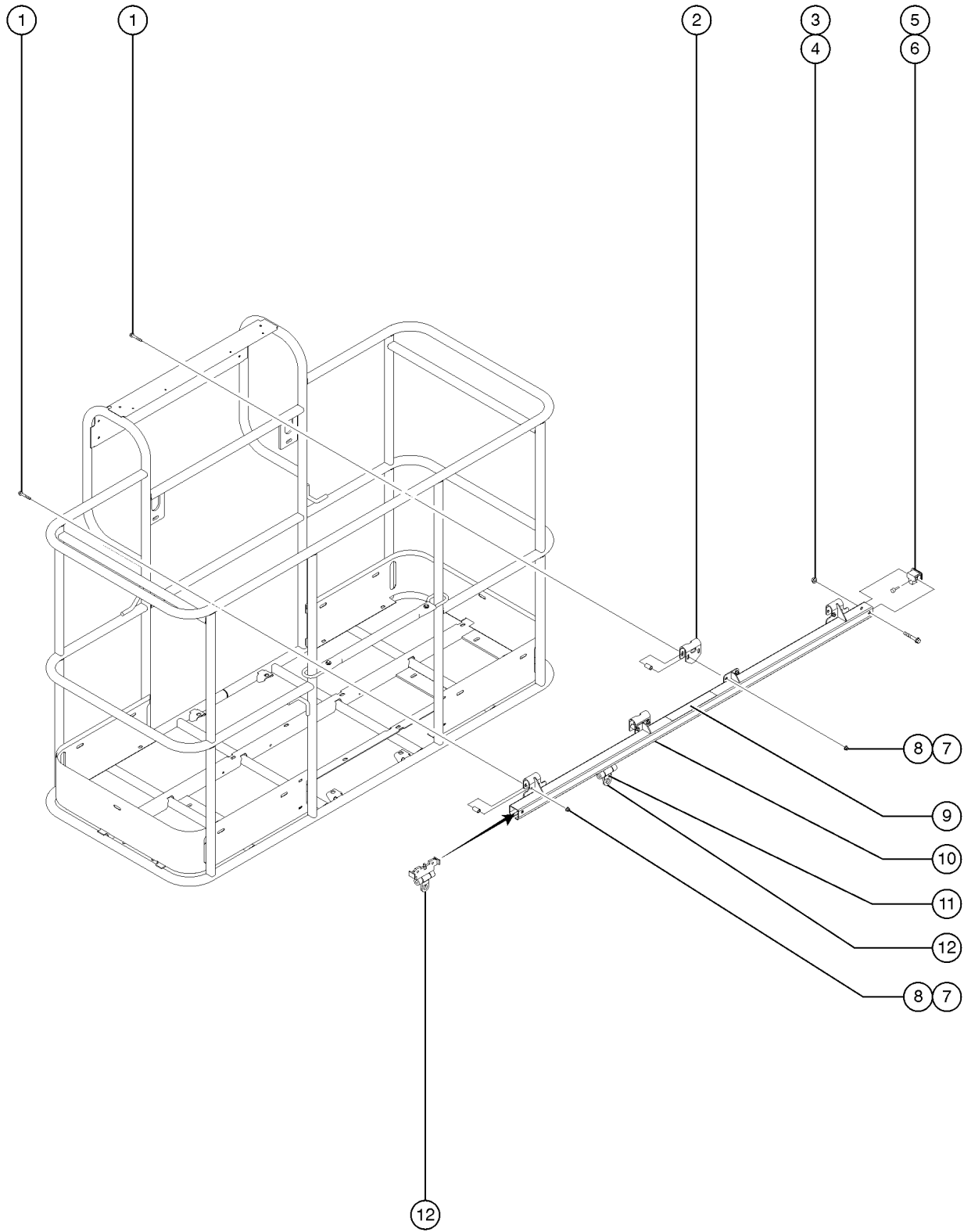

809.1 Traveling Fall Arrest Anchor System

Item	Part No.	Description	Qty.
1	1256856GT	SCREW,HHF,3/8-16X2.5,8,ZAG.....	4
2	1256389GT	FORMING,INNER HANGER.....	2
3	1251997GT	NUT,TL FLG,1/2-13,G,ZAG.....	2
4	1256851GT	SCREW,HHF,1/2-13X3.5,8,ZAG.....	2
5	1260892GT	END STOP,TRACK,FALL ARREST BAR.....	2
6	36388GT	BUMPER,RUBBER,.75 X .50H,STUD....	2
7	1274322GT	NUT,NYLOCK FLG,3/8-16,F,ZAG.....	8
8	1256481GT	SPACER, HANGER BRACKET.....	8
9A	1256400GT	DECAL,TRACK,FALL ARREST BAR,WORD.....	1
9B	1260910GT	DECAL,TRACK,FALL ARREST BAR,SYMBOL.....	1
9C	1256400FRGT	DECAL,TRACK,FALL ARREST BAR,WORD FR.....	1
10A	1256378GT	ACC,FALL ARREST BAR,6FT WORD..... <i>includes instructions and decals</i>	1
--	1256380GT	ASSY,TRACK,FALL ARREST BAR,6FT WORD <i>includes decals</i>	
10B	1261023GT	ACC,FALL ARREST BAR,6FT SYM..... <i>includes instructions and decals</i>	1
--	1261025GT	ASSY,TRACK,FALL ARREST BAR,6FT SYM <i>includes decals</i>	
10C	1261019GT	ACC,FALL ARREST BAR,6FT FR..... <i>includes instructions and decals</i>	1
--	1261021GT	ASSY,TRACK,FALL ARREST BAR,6FT FR <i>includes decals</i>	
11	40434GT	DECAL,LANYARD ANCHORAGE POINT.....	1
12	1256439GT	TROLLEY, TRACK, FALL ARREST BAR.....	1

810.1 Operators Protection Alarm (to January 2017)

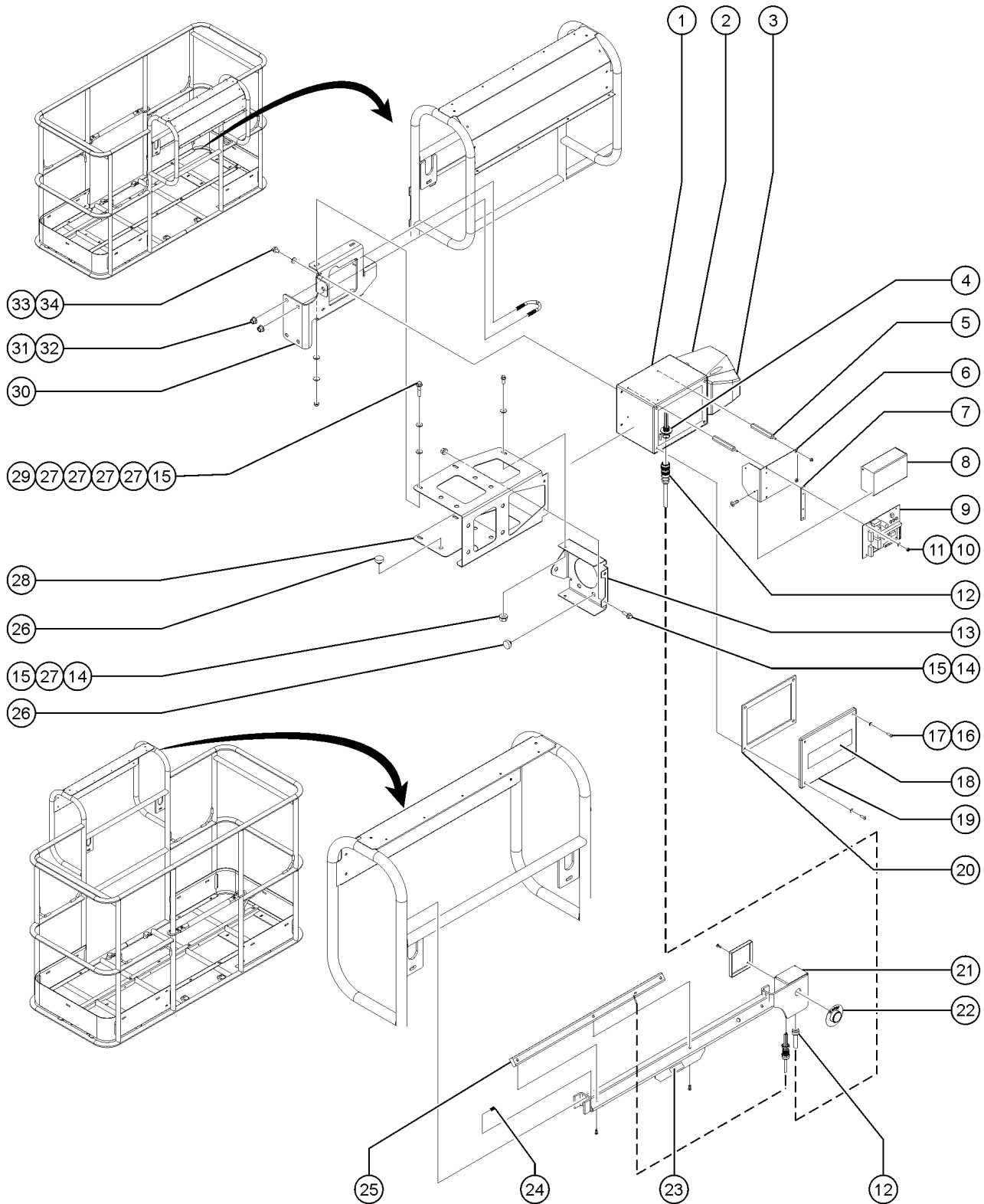

810.1 Operators Protection Alarm (to January 2017)

Item	Part No.	Description	Qty.
B	1275537GT	ASSEMBLY, OPA PROTECTION CAGE.....	1
1	1255018GT	BASE ENCLOSURE,RED,OPA.....	1
2	1255021GT	SOUNDER,MIDI,OPA.....	1
3A	1255037GT	SOUNDER LENS, OPA, BLUE..... <i>(standard lens fitted to OPA)</i>	1
3B	1270116GT	SOUNDER LENS, OPA, RED.....	1
3C	1270117GT	SOUNDER LENS, OPA, AMBER.....	1
3D	1270118GT	SOUNDER LENS, OPA, CLEAR.....	1
4	1255033GT	HARN,PIGTAIL,TAPESWITCH,OPA.....	1
5	1255028GT	STAND OFF,CONTROL UNIT.....	4
6	1255024GT	BRACKET,CONTROL UNIT.....	1
7	1255025GT	SPACER,HEAT SINK.....	1
8	1255023GT	ASSY,MODULE,CONTROL UNIT,OPA....	1
9	1255022GT	MODULE,CONTROL UNIT,PCB,OPA....	1
10	1255067GT	NUT,M4 NYLOCK.....	4
11	1255066GT	WASHER,M4 NYLON.....	4
12	1255035GT	ASSEMBLY,CABLE,TAPESWITCH.....	1
13	1275539GT	FORMING, OPA CAP.....	1
14	824078GT	SCREW,HHF,1/4-20X.75,8,ZAG.....	5
15	824027GT	NUT,TL FLG,1/4-20,G,ZAG.....	9
16	1255038GT	SCREW,M5X16 BHD.....	4
17	1255027GT	WASHER,M5 NYLON.....	4
18	1255890GT	DECAL,COSMETIC,GENIE.....	1
19	1255020GT	LID ENCLOSURE,RED,OPA.....	1
20	1255019GT	GASKET,ENCLOSURE.....	1
21	1255029GT	ASSEMBLY,TAPESWITCH..... <i>"(6/8' platforms) (includes j-box and fasteners)"</i>	1
22	1255036GT	ASSEMBLY RESET SWITCH.....	1
23	1255889GT	DECAL,SYMBOL-READ THE MANUAL.....	1
24	1255068GT	SCREW,M6X8.....	2
25	1255047GT	SENSOR,RUBBER EDGE..... <i>(6/8' platforms)</i>	1
26	43392GT	BUMPER,BATTERY BOX & RAILS.....	17
27	824113GT	WASHER,FLAT,USS,1/4,ZAG.....	19
28	1275538GT	FORMING, OPA CAGE.....	1
29	824080GT	SCREW,HHF,1/4-20X1.25,8,ZAG.....	4
30	1275540GT	FORMING, OPA, BRACKET.....	1
31	824029GT	NUT,TL FLG,3/8-16,G,ZAG.....	4
32	1251600GT	U-BOLT, FLATTENED, 1.5 X 3/8 UNC,ZAG.....	2
33	237238GT	SCREW,HHF,M6-1.0X12,DIN6921,10....	2
34	1257389GT	WASHER, FLAT, M6X18X1.6,DIN9021,ZAB.....	2

810.2 Lift Guard Contact Alarm (from January 2017)

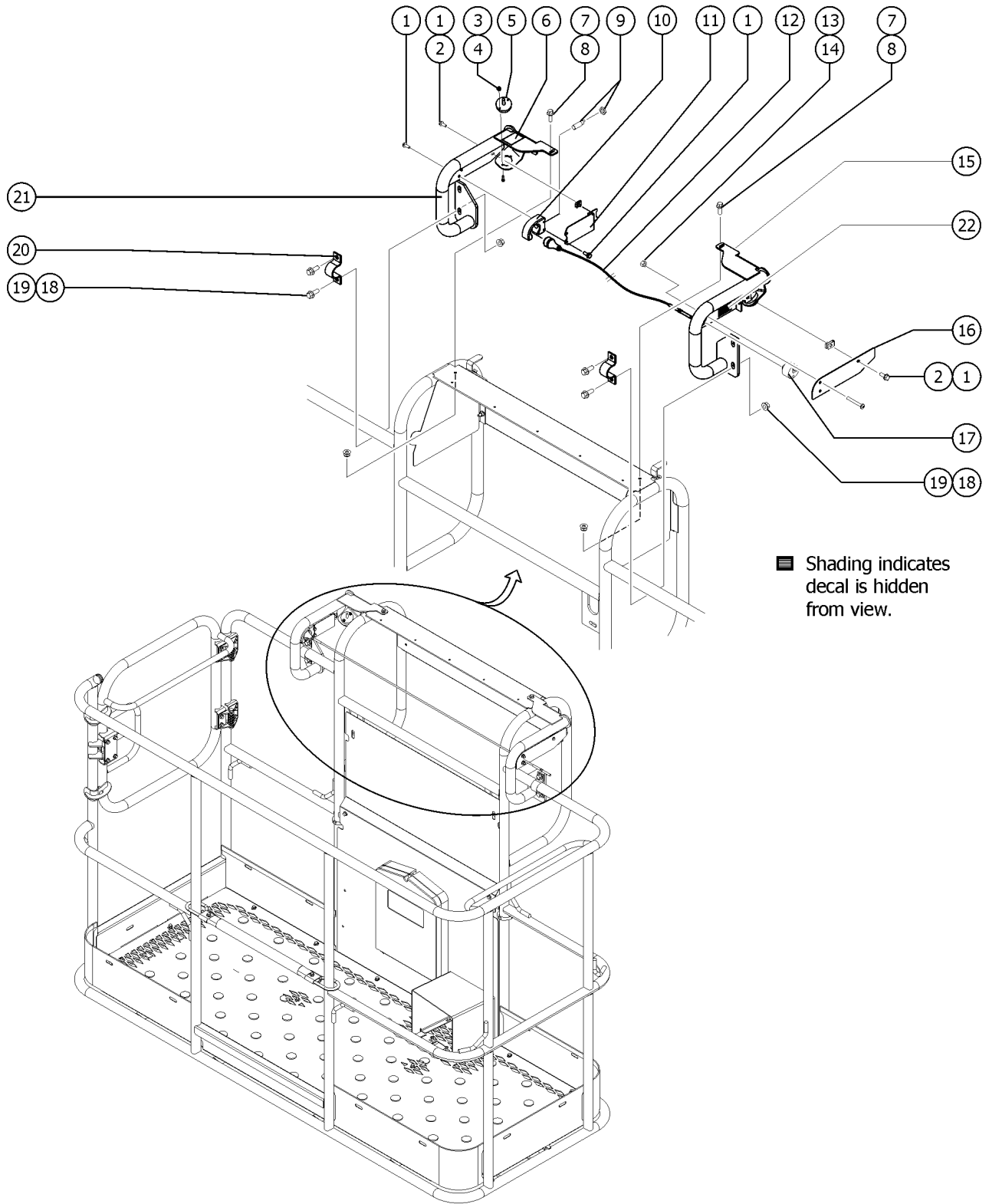

810.2 Lift Guard Contact Alarm (from January 2017)

Item	Part No.	Description	Qty.	Item	Part No.	Description	Qty.
--		From January 2017, this option became a standard installation on all models unless the customer specifically request not to have it installed		21	1278144GT	WELDMENT, LEFT CONTACT ALARM, LARGE.....	1
--	1279135GT	KIT, LIFT GUARD CONTACT ALARM,6'-8' PLATFORM,NON-ALC1000 <i>measure platform before ordering - for 5', 6', and 8' platforms only.</i>		22	1278982GT	DECAL, INSTRUCTION, ACTUATOR SWITCH SOCKET.....	1
--	1278452GT	HARNESS, OPA2, Z45DC/BE					
--	78098GT	RELAY,24VDC,40/30A,SLD W/BRKT*					
--	1278121GT	MODULE, PLUS+1, CONTACT ALARM <i>located inside the Platform Control Box</i>					
1	1264934GT	SCREW,HHF,10-24X.5					
2	73575GT	SPRING CLIP,10-24,.025-.125X.468,ZAG					
3	12344GT	NUT,NYLOCK,6-32					
4	1256859GT	SCREW,PHPM,6-32X.875,ZAG					
5	1278111GT	ASSEMBLY, LIGHT, CONTACT ALARM.....	2				
6	1278542GT	DECAL, INSTRUCTION, CONTACT ALARM					
7	824078GT	SCREW,HHF,1/4-20X.75,8,ZAG					
8	1277924GT	NUT,NYLOCK FLG,1/4-20,F,ZAG					
9	1278119GT	ASSEMBLY, SENSOR, PROX, CONTACT ALARM.....	1				
10	1278433GT	ASSY, SENSOR W/HOUSING <i>(Includes holder item 1277877 and sensor part 1278119)</i>					
--	1277877GT	HOLDER, SENSOR.....	1				
11	1277873GT	FORMING, SENSOR HOLDER.....	1				
12	1278416GT	ASSEMBLY,CONTACT ALARM CABLE, LARGE.....	1				
--	1261184GT	NUT,1/4-20,8,ZAG <i>Part of assembly 1278416</i>					
--	1278124GT	MAGNET, 1/4-20, 15 LB. <i>Part of assembly 1278416</i>					
--	1278368GT	GRIP, CABLE <i>Part of assembly 1278416</i>					
--	1278458GT	CONTACT ALARM WIRE ASSY, LARGE <i>Part of assembly 1278416</i>					
13	825352GT	SCREW,PHPM,10-32X1.25,ZAG					
14	1264261GT	NUT,SERRATED,10-32,ZAG					
15	1278138GT	WELDMENT, RIGHT CONTACT ALARM, LARGE.....	1				
16	1277875GT	PLATE, CABLE AND WIRE COVER.....	1				
17	1277876GT	GUIDE, CABLE.....	1				
18	1274322GT	NUT,NYLOCK FLG,3/8-16,F,ZAG					
19	824090GT	SCREW,HHF,3/8-16X1,8,ZAG					
20	1278363GT	CLAMP, 1.25 INCH TUBE.....	2				



Part Number Index

The Part Number Index is a numeric index of all part numbers included in this manual. The index shows what page(s) the part is used on.

Part Number	Page	Part Number	Page	Part Number	Page	Part Number	Page
1000001GT	14	111051GT	59	1255890GT	113	1275396GT	69
101055GT	83	111052GT	59	1256109GT	57	1275397GT	69
101056GT	83	111053GT	59	1256127GT	57	1275537GT	113
101057GT	83	111526GT	97	1256267GT	51, 55	1275538GT	113
101058GT	83	114020GT	13-14	1256378GT	111	1275539GT	113
101067GT	83	114025GT	14, 17	1256380GT	111	1275540GT	113
10107GT	109	114114GT	14, 17	1256389GT	111	1277873GT	115
101080GT	49	114117GT	14	1256400FRGT	111	1277875GT	115
101114GT	83	114221GT	14	1256400GT	111	1277876GT	115
101277GT	83	114247GT	17	1256439GT	111	1277877GT	115
101425PGT	25	114248GT	17	1256460GT	71	1277924GT	115
101426PGT	25	114249GT	17	1256481GT	111	1278111GT	115
101512GT	103	114252GT	17	1256847GT	57	1278119GT	115
101579GT	73-74	114334GT	17	1256851GT	111	1278121GT	115
101815GT	31	114343GT	17	1256855GT	71	1278124GT	115
101844GT	43	114345GT	17	1256856GT	111	1278138GT	115
101852GT	99	114350GT	14, 17	1256859GT	115	1278144GT	115
101853GT	99	114389GT	14	1256922GT	57	1278363GT	115
101858GT	47	114390GT	14	1257389GT	113	1278368GT	115
101859GT	47	114397GT	14	1257733GT	11	1278416GT	115
101860GT	45	119058GT	71	1258159GT	51	1278433GT	115
101861GT	45	119060GT	43	1258567GT	11	1278452GT	115
101862GT	47	119061GT	40	1258768GT	43	1278458GT	115
101863GT	45	119062GT	40	1259322GT	49	1278542GT	115
101864GT	45	119063GT	40	1259323GT	49	1278982GT	115
102785PGT	97	119064GT	40	1259639GT	49	1279135GT	115
102786PGT	97	119209GT	22-23	1260173GT	49	128045GT	43, 103
102992GT	71	119210GT	22-23	1260892GT	111	1280665GT	27, 35
104804GT	71	119403GT	35	1260910GT	111	128118GT	27
10597GT	35, 37, 55	119404GT	35	1261019GT	111	128200GT	39-40, 73-74
106069GT	45	119536PGT	63, 67	1261021GT	111	128201GT	40, 73-74
106117GT	21-23	119542GT	63, 67	1261023GT	111	128202GT	39-40, 73-74
106120GT	21-23	119784PGT	35	1261025GT	111	128204GT	109
106121GT	21-23	119825GT	83	1261184GT	115	128301GT	57
106122GT	21-23	119950GT	99	1261221GT	49	128304GT	57
106123GT	21-23	119980GT	21-23	1261845GT	49	128308GT	59
106124GT	21-23	119981GT	19	1261899GT	49	128309GT	59
106125GT	21-23	12011GT	59	1261900GT	49	128310GT	59
106126GT	21-23	120282GT	55	1262220GT	49	128311GT	59
106148GT	21-23	121848GT	49, 103	1262223GT	49	128319GT	33
106163GT	65	122019GT	95	1262512GT	49	128337GT	21-23
106241GT	25	122073GT	97	1262633GT	55	128368GT	99
106427GT	31, 53	122231GT	97	1263057GT	55	128374GT	99
106526GT	61	122278GT	97	1263554GT	21-23	128375GT	27
106540PGT	63	122279GT	97	1264261GT	57, 115	1283776GT	11
106581GT	63	122513GT	73-74	1264308GT	14	1283777GT	27
106972GT	53	122514GT	73-74	1264822GT	49	1283806GT	22-23
107588GT	51	12343GT	59	1264834GT	49	1284282GT	49
107590GT	51	12344GT	115	1264934GT	115	128428GT	63
107594GT	45	1251600GT	113	1265481GT	57	128446GT	31
107595GT	61	1251997GT	111	1266606GT	49	128454PGT	67
107651GT	31	1255018GT	113	1267570GT	85	128465GT	29
107727GT	51	1255019GT	113	1267746GT	71	128466GT	29
10775GT	74	1255020GT	113	1267747GT	71	1284764GT	97
10777GT	74	1255021GT	113	1267779GT	19	128482GT	67
107857GT	97	1255022GT	113	1267780GT	22-23	128483GT	67
107858GT	97, 109	1255023GT	113	1267781GT	19	128486GT	29
107859GT	51	1255024GT	113	1267782GT	19, 22-23	128487GT	29
107881GT	53	1255025GT	113	1267784GT	19	128488GT	29
110160GT	31	1255027GT	113	1267785GT	22-23	128489GT	29
110305GT	53	1255028GT	113	1267786GT	19	128490GT	29
110306GT	53	1255029GT	113	1267787GT	22-23	128491GT	29
110307GT	53	1255030GT	49	1268GT	11	128492GT	29
110308GT	53	1255033GT	113	1269501GT	77	128510GT	67
110309GT	55	1255035GT	113	1270116GT	113	128513GT	67
110310GT	53	1255036GT	113	1270117GT	113	128534GT	67
110382GT	33, 45	1255037GT	113	1270118GT	113	128578GT	39-40, 73-74
110651GT	73-74	1255038GT	113	1270353GT	89	128580-SGT	39-40, 73-74
110652GT	73-74	1255047GT	113	1272303GT	69	128581-SGT	40, 73-74
110653GT	73-74	1255066GT	113	1272307GT	71	128582-SGT	39-40, 73-74
110654GT	73-74	1255067GT	113	1274322GT	111, 115	128598GT	21-23
110657GT	49	1255068GT	113	1274858GT	69	128601GT	57
110671GT	65	1255452GT	55	1275393GT	69	128603GT	57
110737GT	21-23	1255858GT	49	1275394GT	69	128605GT	57
110789GT	103	1255889GT	113	1275395GT	69	128645GT	27, 35

Part Number	Page	Part Number	Page	Part Number	Page	Part Number	Page
128646GT	35	147041GT	107	228947GT	27	33550GT	13-14, 17
1286600GT	21-23	147094GT	39-40	228973GT	27	33556GT	45
1286602GT	21-23	147121GT	71	229567GT	39-40, 73-74	33674GT	99
1286603GT	21-23	147181GT	107	229798GT	19	33724GT	74
128724GT	67	147184GT	107	229833GT	22-23	33952GT	13-14
1287821GT	57	147187GT	22-23	229834GT	22-23	33994GT	11, 87, 89, 91, 93
1287986GT	83	147210GT	31	232486GT	21-23	34053GT	43
128812GT	49	147211GT	31	232574GT	89	34125GT	57
128816GT	49	147212GT	31	232575GT	93	34245GT	19
128825GT	27	147253GT	73-74	233715GT	65	34276GT	55
128852GT	107	147283GT	63	233716GT	61	34619GT	97, 103
128862GT	59	147284GT	55	233745GT	61, 65	35461GT	74, 95
128929-300GT	29	147369GT	61, 65	233807GT	21-23	35675GT	63
128941GT	49	147509GT	103	23404GT	43	35678GT	79
128956GT	109	1484GT	11	234923GT	77	35679GT	79
128973GT	107	1487GT	99	237145GT	73-74	35680GT	79
128995GT	57	1488GT	99	237238GT	113	35956GT	97
129021GT	83	150026GT	33	237688GT	53	35960GT	97
12906GT	45, 47	150103GT	57, 61, 63	24514GT	71	36179GT	33, 35
13000GT	25, 35	15086GT	103	25068GT	31	36212GT	25
13002GT	22-23, 35, 65, 97	16073GT	101	25388GT	27, 35	36294GT	61, 65
13037-SGT	73-74	160809GT	69	25553GT	40	36369GT	25
13064GT	21-23, 31	161541GT	69	25683GT	61, 63	36372GT	22-23
13268GT	33, 74	161542GT	69	25685GT	103	36388GT	111
133067GT	17	161940GT	25	25817GT	19	36555GT	11
133286GT	17, 27	161941GT	25	27114GT	45	36557GT	73-74, 79
13585GT	74	1697-400GT	53	27204GT	13-14, 17	36579GT	25
139011-SGT	29	17626GT	22-23	27205GT	13-14, 17	37184GT	33, 35
139020GT	29	17712GT	31	27206GT	13-14, 17	37185GT	33, 35
139041GT	29	18503GT	22-23	27207GT	13-14, 17	37186GT	33, 35
139047GT	29	18506GT	33	27246GT	39-40, 73-74, 109	37187GT	33, 35
139048GT	29	18576GT	21-23	27391GT	49	37189GT	22-23
139049GT	29	18605GT	95	27497GT	63	37191GT	33, 35
139050GT	29	18720GT	51, 55	27564GT	13-14	37192GT	33, 35
139051GT	29	18963GT	35	27581GT	11	37947GT	39-40
139052GT	29	19418GT	21-23	28161GT	13-14	38859GT	47
139053GT	29	19440GT	19	28165GT	13-14	39223GT	37
139054GT	29	19506GT	39-40	28174GT	13-14, 17	39346GT	83
139055GT	29	19520GT	25	28175GT	13-14	40433GT	79
139056GT	29	19712GT	77	28176GT	13-14	40434GT	13-14, 17, 111
139057GT	29	19722GT	77	28177GT	13-14	42019GT	37
139058GT	29	19729GT	79	28181GT	13-14	42078GT	47
139059GT	29	19731GT	77, 79	28235GT	13-14, 17	42104GT	99
139060GT	29	20262GT	71	28236GT	13-14	42502GT	57
139062GT	29	21166GT	19	28322GT	97	4266GT	97, 103
139063GT	29	21175GT	31	28323GT	97	42725GT	73-74
139064GT	29	21427GT	77	28328GT	97	42941-75GT	53
139099GT	93	21434GT	77	28329GT	97	43018GT	63, 85
13918GT	45	214814GT	89	28372GT	13-14	43038GT	77
139318GT	27, 35	214816GT	89	28678-2250GT	93	43040GT	77
139351GT	21-23	215777GT	21-23	28678GT	91	43042GT	77
139353GT	21-23	21604GT	103	28750GT	11, 87, 89, 91, 93	43179GT	22-23
139354GT	21-23	21618GT	61	29080GT	57	43181GT	74
139355GT	21-23	21619GT	61	29605GT	47	43392GT	71, 97, 99, 113
139368GT	49	216603GT	83	29868GT	25	43658GT	13-14
139417PGT	47	216769GT	49	30080GT	13-14	43956GT	35
139687GT	61	216791GT	43	30138GT	57	43960GT	53, 71
139688GT	61	216793GT	43	30222GT	61, 63, 65	44174GT	85
139702GT	59	217046GT	43	30255GT	19, 63	44229GT	83
139781GT	59	218083GT	43	30370GT	55	44248GT	13-14
139857GT	27	218154GT	40	30468GT	97	44750GT	81
139861GT	31	218164GT	43, 73-74	30794GT	49	44778GT	22-23
139865GT	31	218433GT	83	30997GT	43	44788GT	37
139866GT	31	218570GT	22-23	31060GT	13-14	44980GT	13-14
139958GT	97	21858GT	39-40	31508GT	13-14	44981GT	13-14, 17
139965GT	22-23	219160GT	14, 17	31779GT	11	44986GT	13-14
139966GT	22-23	21982GT	39-40	31785GT	13-14	45071GT	19, 21-23, 51
139967GT	22-23	220255GT	31	31786GT	13-14	45074GT	19
139968GT	22-23	22262GT	21-23	31787GT	13-14	45112GT	19
14033GT	37, 51	22263GT	21-23	31788GT	13-14	45113GT	19
14297GT	59	226393GT	95	32150GT	11	45114GT	19
144161GT	27, 35	227130GT	14	32151GT	11	45162GT	37, 89
146051GT	21-23	227213GT	14	32317GT	81	45209GT	25
146052GT	21-23	227617GT	71	32728GT	13-14	45363GT	33, 45, 47
146478GT	73-74	228468GT	71	33278GT	61, 65	45383GT	73-74
147034GT	22-23	228946GT	27			45384GT	39-40, 73-74

Part Number Index (continued)

Part Number	Page	Part Number	Page	Part Number	Page	Part Number	Page
45385GT	73-74	50480GT	55, 63	54458GT	99	6090GT	21-23, 37, 40,
45400GT	107	50517-SGT	53	54465GT	99		63, 65, 67, 103
45462GT	35, 43	50519GT	31	54486GT	97	6091GT	22-23, 33, 37,
45748GT	103	50542GT	55	54510-SGT	65		43, 45, 47, 53,
46227GT	77	50543GT	61, 63	54520-SGT	61		59, 61, 63, 65,
46337GT	19	50546GT	57, 63	54534GT	43		67, 97, 99, 103
46468GT	13-14, 17	50548PGT	53	54542GT	19, 21-23	60922GT	97
4828GT	21-23, 27, 31,	50552GT	57	54569GT	57	6095GT	31, 35, 37, 53
	33, 35, 37, 45,	50570GT	35	54570GT	57	6097GT	27, 33, 37, 53,
	51, 55, 59, 63,	50576GT	22-23, 31	54627GT	19		103, 107
	67, 74, 103, 109	50584GT	57	54635GT	105	61306-SGT	63
48504GT	81	50668-SGT	21-23	54638GT	105	6145GT	61, 97
48767-700GT	93	50669GT	22-23	54639GT	105	6146GT	23, 31, 33, 45,
48767GT	91	50698GT	57	54640GT	105		47, 103, 109
48890GT	87	50744-SGT	37	54652GT	105	61726GT	103
48904GT	31, 87, 91, 93	50776PGT	31	54840GT	19	6175GT	19, 37, 53, 55,
48905GT	93	50784GT	45	54883GT	105		109
48906GT	87	50790GT	45, 47	54932GT	99	6178GT	31, 33, 43, 45,
48911GT	89	50952-SGT	53	54959GT	19		47, 53, 109
48912GT	83, 89, 91, 93	50959-SGT	37	54960GT	19	61801GT	40
48916GT	89, 91, 93	50966GT	37	54961GT	19	61972GT	103
48917GT	91, 93	50974GT	33, 45	54962GT	19	61974GT	103
48919GT	91, 93	50990-SGT	45	54989GT	105	61975GT	103
48923GT	91, 93	51063GT	31	54994GT	63	61987GT	103
48939GT	89	51147GT	25, 29	55067GT	65	6198GT	31, 35
48942GT	89, 91, 93	5224GT	67, 107	55753GT	55, 97, 99	61998GT	103
48944GT	89	52371GT	83, 85	56022GT	37	62070GT	13-14, 17
48947GT	89	52664GT	13-14	56234GT	39-40	62088GT	37
48948GT	89	52672GT	13-14	56282GT	22-23	62105GT	22-23
48975GT	89	52707-SGT	21-23	56302GT	43, 73-74	62506GT	85
48999GT	89	52733-SGT	19	56424GT	71	62507GT	85
49117-11091GT	87, 93	52734-SGT	19	56445GT	49	62695GT	22-23
49117-4691GT	87	52735GT	19	56561GT	21-23	62696GT	22-23
49117-9991GT	87	52752-SGT	99	56562GT	21-23	62926GT	13-14, 17
49119-13978GT	91, 93	52753-SGT	99	56680GT	31	62927GT	13-14, 17
49119-16178GT	93	52865GT	13-14	56704GT	95	6326GT	27
49119-20578GT	93	52887GT	77	56773GT	77	6356GT	19, 37, 61, 63,
49119-2078GT	87, 91, 93	52895GT	77	56849GT	53		65, 97
49119-2178GT	91	52897GT	83, 85	56912GT	19, 21-23, 63,	65178GT	77
49119-21878GT	93	52906GT	83		67, 71, 103	65301GT	13-14
49119-2278GT	91, 93	52907GT	83	56925GT	61, 65	65529GT	77
49119-26078GT	91	52910GT	83	56927GT	35	65546GT	77
49119-27478GT	91	52912GT	83	56930GT	22-23	65608GT	21-23
49119-27978GT	91	52913GT	81	56994GT	43	65618GT	21-23
49119-3378GT	89	52914GT	81	57075GT	74	65788GT	57
49119-34378GT	91, 93	52928GT	77	58320GT	21-23	65789GT	63
49119-35678GT	91, 93	52947GT	13-14	58531GT	22-23	6578GT	109
49119-36378GT	91, 93	52969GT	13-14, 17	58919GT	59	65790GT	57
49119-37978GT	91, 93	53157-SGT	97	58920GT	59	6607GT	22-23
49119-39378GT	91	53517GT	109	58927GT	59	6637GT	53
49119-4178GT	93	5361GT	19	58932GT	81	6638GT	21-23, 25, 33,
49120-33381GT	91, 93	5365GT	103	58936GT	81		35, 37, 40, 43,
49121-2088GT	93	53807-SGT	97	58986GT	77		45, 47, 53, 59,
49121-25688GT	91	53808-SGT	97	58987GT	77		61, 65, 67, 73-
49121-27788GT	93	5397GT	21-23, 31, 33,	6002GT	25		74, 97, 99, 103
49143-2029GT	89		35, 37, 45, 59,	60042GT	69	66397GT	29
49143-2535GT	89		61, 63, 65, 74,	60065GT	37	66399GT	11
49164-2043GT	89		97, 109	60106PGT	33	66717GT	21-23
49212GT	101	54063GT	57	60110GT	45	66812GT	39-40, 73-74
49214GT	101	54065GT	61, 63	60126-SGT	45	66813GT	73-74
49215GT	101	54145-800GT	31	60145GT	47	66815GT	73-74
49612GT	11, 87, 89, 91, 93	54156GT	51	60160PGT	71	66818GT	39-40, 73-74
49613GT	11, 87, 89, 91, 93	54157GT	57	6019GT	19, 33, 61, 63, 74	66821GT	73-74
49772GT	53	54165GT	99	6021GT	19, 21-23, 31,	66900GT	25
49775GT	53	54231GT	37		33, 35, 37, 53,	66901GT	25
49816GT	33, 45, 47, 77	54247PGT	71		55, 67, 81, 107	6708GT	21-23
49818GT	22-23	54255GT	43, 73-74	6033GT	37, 51, 53, 55	6782GT	22-23, 35, 65,
49821GT	95	54259GT	73-74	60433GT	43		109
49863GT	63, 65	54271GT	59	60435GT	40	6833GT	53
49878GT	33, 35	54360GT	37	60443GT	73-74	6878GT	59, 107
50294GT	69	54363GT	33, 45	60447GT	43	6886GT	22-23, 35, 97
50452GT	59	54365GT	43, 109	60526GT	40, 43, 73-74	6888GT	19, 25, 33, 37,
50455GT	51	54436GT	19	60527GT	40		43, 45, 47, 53,
50466-SGT	63	54443GT	37	60528GT	40		59, 61, 103
50469GT	31	54455PGT	47	60757GT	43	6889GT	97, 107
50479-SGT	53	54457GT	99			6935GT	35, 74

Part Number Index (continued)

Part Number	Page	Part Number	Page	Part Number	Page	Part Number	Page
70534GT	55	77376GT	57	83093GT	39-40	T108075GT	61, 63
7056GT	35, 74	77410GT	57	83131GT	39-40	T108673GT	22-23
70574PGT	35	77434GT	19	84385GT	83	T112560GT	74
70642PGT	101	77435GT	37	8516GT	33, 35, 45, 55, 61, 63	T112773GT	17
70644-75792GT	101	7746GT	97	85239GT	39-40	T115351GT	89
70647PGT	35	77521GT	51	87755GT	43	T115412GT	45
70657GT	21-23	77524GT	47	88203GT	51		
70685PGT	53	77677GT	22-23	88337GT	19		
72282GT	95	77709GT	83, 85	88338GT	19		
72298GT	77	77981GT	81	88356-11103GT	31		
72326GT	35, 43, 73-74	77990GT	81	88356-11163GT	53		
72444GT	13-14, 17	78098GT	49, 77, 115	88356-11205GT	53, 57		
7265GT	47, 99	78622GT	37	88370PGT	53		
72833GT	13-14	79452GT	23	88516GT	65		
72867GT	13-14, 17, 109	79456GT	67	88557GT	37		
73233GT	71, 73-74	81096GT	74	88606PGT	97		
7339GT	97	81175GT	63	88607PGT	97		
73477PGT	71	81458GT	74	88609-SGT	97		
73574-SGT	71	81579GT	35	88635-4024GT	31		
73575GT	22-23, 71, 115	81640GT	67	88637GT	43		
73587GT	23	8177GT	51, 53, 55	88676GT	51, 55		
73610PGT	71	8179GT	47	88691GT	40		
73634GT	103	822005GT	13-14	88713GT	49		
73711GT	73-74	822006GT	13-14	88719GT	31, 40		
73713GT	73-74	822013GT	13-14	88721-70700GT	40, 49		
73717GT	43, 73-74	822014GT	13-14	88721-72000GT	40		
73723GT	73-74	822038GT	13-14	88722-70700GT	40, 49		
73736GT	40, 43, 73-74	822039GT	13-14	88722-72000GT	40		
73739GT	71	822777GT	49	88723-69700GT	40, 49		
73749GT	40	822778GT	49	88723-71000GT	40		
73751GT	40	82279GT	14, 17	88724GT	49		
73753GT	40	823153GT	17	88725GT	49		
73754GT	40, 43	823154GT	17	88752GT	19		
73805GT	39-40	823161GT	17	88827GT	39-40		
73807GT	61, 85	823162GT	17	88832GT	49		
73900GT	69	823226GT	109	8914GT	22-23, 53, 73- 74, 97, 99		
73901GT	99	82366GT	14	8915GT	22-23, 45, 63, 67		
74006GT	74	823684GT	25	89756GT	53		
74266GT	22-23	823774GT	49	89862GT	85		
74267GT	21-23	824027GT	57, 71, 113	89864GT	85		
74268GT	21-23	824029GT	71, 113	93500GT	11		
74362GT	77	824049GT	29	94001GT	25		
74364GT	77	824050GT	31	94002GT	25		
74365GT	77	824051GT	31	94003GT	25		
74366GT	77	824052GT	31	94077GT	33, 45		
74367GT	77	824063GT	57	94195GT	65		
74368GT	77	824068GT	57	94315GT	22-23		
74468GT	21-23	824078GT	71, 113, 115	94316GT	22-23		
74469GT	21-23	824079GT	71	94317GT	22-23		
74470GT	21-23	824080GT	113	94492PGT	103		
74471GT	22-23	824082GT	57	94506GT	39-40		
74495GT	21-23	824090GT	71, 115	94529GT	53		
74712GT	31	824110GT	57	94530GT	53		
74911GT	43	824113GT	57, 113	94531PGT	53		
74913GT	43	824124GT	57	94549GT	103		
74917GT	43	824151GT	57	94618GT	83		
75073GT	45, 47	824164GT	57, 63	94643GT	103		
75076GT	45, 47	824228GT	25	94745GT	71		
75453GT	83	82472GT	17	94745PGT	97		
77014GT	55	82473GT	17	94860GT	83		
77032GT	47	82481GT	17	94879GT	21-23		
77034PGT	47	82487GT	17	94880GT	21-23		
77051GT	61, 65	825019GT	19, 21-23, 55, 57, 61, 63	94981GT	33		
77059-2986GT	89			94982GT	33		
77059-4086GT	89	825352GT	115	9599-SGT	97		
77061GT	39-40	825358GT	57	96008-SGT	39-40		
77103GT	91	82548GT	17	97128GT	31, 53, 57		
7713GT	37, 53, 61	8255GT	31, 33, 35, 37, 67	97815GT	14, 17		
77181GT	67	825796GT	19	97887GT	14		
77189GT	55	82601GT	17	97890GT	14		
77246GT	31	82602GT	17	9990074GT	21-23		
77303GT	51	82604GT	17	T106699GT	43, 73-74		
77362GT	55	82612GT	17	T107883GT	63		
77363GT	61, 63	82647GT	17	T107884GT	61, 63		
77364GT	55, 61, 63	82679GT	83				
77375GT	57	82774GT	17				

Part Description Index

The Part Description Index is an alphabetical index of all part descriptions included in this manual. The index shows what page(s) the part is used on.

A

ACC,FALL ARREST BAR,6FT FR.....111
 ACC,FALL ARREST BAR,6FT SYM.....111
 ACC,FALL ARREST BAR,6FT WORD.....111
 ALARM,CHIME TONE 5-25VDC***.....35, 43
 ALARM,INTERMITTENT TONE 6-30V*.....35
 ALARM,WARBLE TONE 5-30 VDC***.....73-74
 AMMETER, 39243/47906/66412.....19
 ANGLE,RELAY MNT,W/NUTSERTS,PNT.....43
 ARCTIC HOSES, Z45J ELEVATE.....63
 ASSEMBLY RESET SWITCH.....113
 ASSEMBLY, LIGHT, CONTACT ALARM.....115
 ASSEMBLY, OPA PROTECTION CAGE.....113
 ASSEMBLY, SENSOR, PROX, CONTACT ALARM.....115
 ASSEMBLY,CABLE,TAPESWITCH.....113
 ASSEMBLY,CONTACT ALARM CABLE, LARGE.....115
 ASSEMBLY,FOOT SWITCH.....71
 ASSEMBLY,FOOT SWITCH***.....71, 73-74
 ASSEMBLY,TAPESWITCH.....113
 ASSY, CIRCUIT BREAKER 15A.....39-40
 ASSY, SENSOR W/HOUSING.....115
 ASSY,4FT PLATFORM, NO DECALS.....69
 ASSY,5FT PLATFORM, NO DECALS.....69
 ASSY,6' PLAT WELDMENT W/SIDE GATE.....69
 ASSY,6FT PLAT DUAL LG,BLANK W/SIDE SWING GATE.....69
 ASSY,6FT PLATFORM,NO DECALS.....69
 ASSY,LED,IES CHARGER.....27
 ASSY,LS,LOAD SENSE,38.5 IN.....49, 103
 ASSY,MODULE,CONTROL UNIT,OPA.....113
 ASSY,RELAY SOCKET, AUTO.....43
 ASSY,SIDE SWING GATE.....71
 ASSY,TERMINAL RAIL,Z45DC/BE.....43
 ASSY,TRACK,FALL ARREST BAR,6FT FR.....111
 ASSY,TRACK,FALL ARREST BAR,6FT SYM.....111
 ASSY,TRACK,FALL ARREST BAR,6FT WORD.....111
 AUX TOP RAIL,6'(1.25")SERVICE.....97
 AUX TOP RAIL,6', SWG GT, SRV.....97
 AUX TOP RAIL,8'(1.25")SERVICE.....97
 AUX TOP RAIL,8', SWG GT, SRV.....97
 AXLE ASSY,FRONT,NARROW Z45/Z51.....19
 AXLE ASSY,NON-STR,NARROW BASE.....21-23
 AXLE ASSY,REAR,NARROW Z45/Z51.....21-23
 AXLE COVER,NARROW.....22-23

B

BACKING PLATE, HOSE BLOCK, JIB.....67
 BACKING PLATE, PULLTUBE.....59
 BALL STUD**.....45
 BALL STUD,1/2" BALL,3/8-16X1.2.....45
 BAR, AXLE ROTATION STOP.....21-23
 BASE ENCLOSURE,RED,OPA.....113
 BASE, W/1 N.O. CONTACTS***.....73-74
 BASE,W/2 NC CONTACTS***.....39-40
 BASE,W/3 NC CONTACTS.....39-40
 BASE,WITHOUT CONTACTS.....73-74
 BATTERY BOX ASSY, LH.....25

BATTERY BOX ASSY, RH.....25
 BATTERY BOX ASSY,CONTRL SIDE**.....25
 BATTERY BOX ASSY,TANK SIDE***.....25
 BATTERY CABLE ASSY,9.5"JUMPER.....25
 BATTERY, 350AH,GROUP L16G(DRY).....25
 BATTERY,AGM,6V/390A,L16.....25
 BEARING KIT.....21-23
 BEARING KIT, AUSCO***.....21-23
 BEARING KIT, OMNI.....22-23
 BEARING KIT,4HP.....21-23
 BEARING KIT,GE DRIVE MOTOR***.....22-23
 BEARING KIT,WHEEL DRIVE W/BRAKE (101584/101585).....21-23
 BEARING NUT***.....21-23
 BEARING,0.75IDX1.00ODX0.75L.....25
 BEARING,1.00IDX1.25ODX1.00L.....19
 BEARING,1.25IDX1.50X1.25L.....19
 BEARING,1.25IDX1.50DX1.00L.....55
 BEARING,1.5IDX1.75ODX1.5L.....19, 21-23, 51
 BEARING,2.0IDX2.25ODX1.50L.....51, 55
 BEARING,FL,1.25IDX1.41ODX1.50L.....61, 63, 65
 BEARING,FL,1.25IDX1.50DX1.25L.....63
 BEARING,FL,1.5IDX1.75ODX1.10LG.....51
 BEARING,GARLOCK,12FDU12.....103
 BEARING,INNER,9 BOLT HUB***.....19
 BEARING,MOTOR,36843,BRUSH END*.....22-23
 BEARING,OUTER,9 BOLT HUB***.....19
 BEARING,POLYGON,20DU12.....61, 63
 BEARING,POLYGON,BM5120.....55
 BEARING,SWING CHASSIS.....31
 BELL CRANK,JIB,WELD/Z45/25***.....63
 BELLOWS,CYL,KIT,Z45&Z51 JIB.....105
 BELLOWS,JIB CYLINDER.....105
 BELLOWS,MASTER CYLINDER.....105
 BELLOWS,PRIMARY CYLINDER,JIB.....105
 BELLOWS,SECONDARY,ELEVATE CYL.....105
 BELLOWS,SLAVE CYLINDER.....105
 BELLOWS,STEERING CYLINDER.....105
 BOLT,CARRIAGE,1/4-20 X .75,G2.....59, 107
 BOLT,CARRIAGE,1/4-20 X 1.00,G2.....67
 BOLT,CARRIAGE,1/4-20 X 2.75,G2.....67
 BOLT,CARRIAGE,1/4-20X.75,5,ZAG.....57
 BOLT,CARRIAGE,1/4-20X1.5,ZAG.....57
 BOOM REST WELDMENT.....53
 BOOT(BELLOWS),E-STOP,BLACK.....73-74
 BOOT,CABLE TERMINAL,LG,RED,2/0.....25, 29
 BOOT,CIRCUIT BREAKER PROTECTOR.....39-40
 BOOT,CONTROLLER**.....77
 BOOT,PLUG 4 WAY.....71
 BOOT,TOGGLE SWITCH.....40
 BOOT,TOGGLE SWITCH,SHORT*.....39-40, 73-74, 109
 BOOT-THUMB ROCKER** BLACK.....77
 BOX,INSTRUCTION STORAGE.....71
 BRACKET ENGAGE II.....73-74
 BRACKET, CHARGER CORD AND LED.....27
 BRACKET, HOSE CLAMP SUPPORT.....61
 BRACKET, RETURN FILTER.....37
 BRACKET,AIR HOSE TO PLAT PAINT.....101
 BRACKET,CONTROL UNIT.....113
 BRACKET,DRIVE SENSOR,ENABLE.....31

BRACKET,GROUND CONTROL BOX.....37
 BRACKET,HOSE CLAMP PAINTED***.....53
 BRACKET,HOSE CLAMP SUPPORT.....61
 BRACKET,HOSE CLAMP,PAINTED.....63, 67
 BRACKET,MUFFLER,RIGHT.....83
 BRACKET,POWER TO PLAT, DOM.....74
 BRACKET,RELAY MOUNT W/INSERTS.....43, 73-74
 B R A C K E T , R U B B E R BUMPER,ENGCOVER.....33, 45
 BRACKET,WORK LIGHT MOUNT 5/16".....97
 BRACKET-TOOL TRAY MOUNTING.....97
 BRAKE KIT, SWING DRIVE.....31
 BRAKE REPLACEMENT KIT.....21-23
 BRAKE, NEMA, 1200 IN/LB.....21-23
 BRUSH COVER -PLATE-(48504)*.....81
 BRUSH HOLDER(56282).....22-23
 BRUSH KIT, DRIVE MOTOR.....22-23
 BRUSH KIT,GE DRIVE MOTOR***.....22-23
 BRUSH RETAINING SPRING,DR MTR.....22-23
 BRUSH SET 4 EA.....81
 BULB,WORKLIGHT,12V 35W.....97
 BULKHEAD FITTING,PLASTIC X 8***.....37
 BULKHEAD,SWING,RIGHT,Z45 DC/BE.....37
 BUMPER, PLASTIC, 1.25 O.D.....55, 97, 99
 BUMPER,BATTERY BOX & RAILS.....71, 97, 99, 113
 BUMPER,RUBBER***.....97, 103
 BUMPER,RUBBER,.75 X .50H,STUD.....111
 BUMPER,RUBBER,COVERS.....33, 45
 BUSHING,STRAIN RELIEF,875/.30.....27, 35
 BUSHING,STRAIN RELIEF,875/.40.....27
 BUTTON,PUSH,BLACK W/SEAL***.....73-74
 BUTTON,PUSH,RED MUSHROOM HEAD.....39-40, 73-74

C

C-CLIP, SHAFT, JOYSTICK.....77
 CABLE ASSY #2 BLK ALT(-)/GND.....29
 CABLE ASSY #2 BLK AP-A2/GND.....29
 CABLE ASSY #2 BLK AP-A2/LP-A1.....29
 CABLE ASSY #2 BLK AP1/AP2 BATT.....29
 CABLE ASSY #2 BLK AP1/AP2 DRIV.....29
 CABLE ASSY #2 BLK AP2/FU1 DRIV.....29
 CABLE ASSY #2 BLK B(+)/A2.....29
 CABLE ASSY #2 BLK B(-)/GND.....29
 CABLE ASSY #2 BLK BE AP2 BATT.....29
 CABLE ASSY #2 RED A1/A1.....29
 CABLE ASSY #2 RED ALT(+)/F2.....29
 CABLE ASSY #2 RED AP1/FU1 DRIV.....29
 CABLE ASSY #2 RED AP2 BATT.....29
 CABLE ASSY #2 RED AP2/FU1.....29
 CABLE ASSY #2 RED AP2/FU2 DRIV.....29
 CABLE ASSY #2 RED B(+)/PR1.....29
 CABLE ASSY #2 RED BATT.....29
 CABLE ASSY #2 RED M(-)/A2.....29
 CABLE ASSY #2 RED PR2/F2.....29
 CABLE ASSY #2 RED PR2/LP-D1.....29
 CABLE ASSY #2 RED PR3/AP-DI.....29
 CABLE COVER,JIB PAINTED.....63
 CABLE TIE,7 3/8".....109
 CABLE TRACK, NP400, 23 LINK.....59
 CABLE TRACK,PLASTIC,35 LINK.....59
 CAM ASSEMBLY, JOYSTICK(42032).....77
 CAP,DISENGAGE,4HP/4HB***.....21-23

CAP,DISENGAGE,OMNI***.....22-23	CONTACT-MOVEABLE (56434)**.....22-23	DECAL, INSTRUCTION, ACTUATOR SWITCH SOCKET.....115
CAP,DUST (54840 HUB ASSY).....19	CONTACTOR,AUX PUMP 24V,80A***.....21-23	DECAL, INSTRUCTION, CONTACT ALARM.....115
CAPACITOR,TIME DELAY.....74	CONTACTOR,DRIVE,24V,180A***.....21-23	DECAL, INSTRUCTION, OPS.....14, 17
CASTING 42032.....77	CONTACTOR,LIFT PUMP 24V 180A**.....22-23	DECAL, POWER TO CHARGER, UNIV.....17, 27
CHARGER 48V/30A AUTO AC X-LED.....27	CONTROL BOX COVER ASSY***.....97	DECAL, POWER TO PLATFORM 230V**.....13-14, 17
CHOCK,CYLINDER (SERVICE TOOL).....11	CONTROL BOX COVER,LID,PTD.....97	DECAL, SYMBOL - READ THE MANUAL.....17
CLAMP, #4 HOSE, AIR AND LOOM.....61	C O N T R O L R , S E P E X MOTOR,Z45DC/BE.....21-23	DECAL,AC INVERTER POWER,115V.....14, 17
CLAMP, 1.25 INCH TUBE.....115	CONVERTER, DC-DC, 48-26 VOLT**.....23	DECAL,ANNUAL INSP***.....13-14
CLAMP, JIB HOSE/CABLE, Z45/51.....59	CORD AC IEC320-C19 TO 110UK.....35	DECAL,ARROW BLUE.....13-14, 17
CLAMP, PRI, HOSE/CABLE, Z45/51.....57	CORD AC IEC320-C19 TO 110US.....27	DECAL,ARROW YELLOW LRG 9".....13-14, 17
CLAMP,0.50,#8 X 1/4,RUB CUSH.....53	CORD AC IEC320-C19 TO 220EU.....27, 35	DECAL,BATT CONN DIAGRAM.....14
CLAMP,0.63,#10 X 1/4,RUB CUSH.....101	CORROSION INHIBITOR,FOAM.....43	DECAL,CHEVRON RANDO HD.....14
CLAMP,0.75,#12 X 1/4,RUB CUSH.....33, 74	COUNTERWEIGHT,CAST,DC/BI,W/JIB.....47	DECAL,COSMETIC,DC POWER.....13-14, 17
CLAMP,1.13,#18 X 1/4,RUB CUSH.....61	COUPLER, PUMP / MOTOR (36179).....33, 35	DECAL,COSMETIC,GENIE.....113
CLAMP,1.13,#18 X 3/8,RUB CUSH*.....63, 65	COUPLING.....21-23	D E C A L , C O S M E T I C , G E N I E BOOM,HORZ.....13-14, 17
CLAMP,1.25,#20 X 1/4,RUB CUSH.....99	COUPLING-POT,JOYSTICK (56579).....77	DECAL,COSMETIC,GENIE Z-45/25.....13-14, 17
CLAMP,1.25X.5 RUBBER-CUSHION.....71	COVER ASSY W/SYM DECALS,LH.....45	DECAL,COSMETIC,GENIE Z-45/25J.....13-14, 17
CLAMP,1.50,#24 X 1/4,RUB CUSH.....61	COVER ASSY W/SYM DECLS,LH DC.....45	DECAL,COSMETIC,GENIE Z-45/25J.....13-14, 17
CLAMP,1.63,#26 X 3/8,RUB CUSH.....67	COVER ASSY W/WRD DECALS,LH BI.....45	DECAL,DANGER DO NOT ALTER SWTC.....13-14
CLAMP,HOSE ROUTE,2X#4,LOOM.....61	COVER ASSY W/WRD DECALS,LH DC.....45	DECAL,DANGER,BATTERY SAFETY***.....13-14
CLAMP,JIB HOSE Z45.....63	COVER ASSY W/WRD DECALS,RH BI.....47	DECAL,DANGER,ELEC.HAZ.STAY CLR.....13-14, 17
CLAMP,JIB HOSE/CABLE,Z45/51.....67	COVER ASSY W/WRD DECALS,RH DC.....47	DECAL,DANGER,ELECT HAZARD***.....14
CLAMP,RUBBER CUSHIONED-2 5/32.....63	COVER PLATE,AIR INTAKE,GRAY.....45	D E C A L , D A N G E R , E L E C T HAZARD,PLUG.....13-14
CLAMP,TWO HOSE.....63, 67	COVER PLATE,CONNECTOR.....40	DECAL,DANGER,GEN SAFETY RULES.....14
CLAMPING BLOCK,CABLE.....53	COVER W/DECALS,STEER,NON OSC.....19	DECAL,DANGER,GENERAL SAFETY.....14
CLAMPING BLOCK,HOSE***.....53	COVER, DRIVE, DRIVE LIGHT OPT.....109	DECAL,DANGER,MAX CAP,200KG.....17
CLIP,RETAINING,IES CHARGER.....27	COVER, FOOT SWITCH, LARGE.....71	DECAL,DANGER,MAX SIDE FRC,667N.....17
COIL, 24V, DEUTSCH NO DIODE.....83	COVER, JIB HOSES/CABLES.....67	DECAL,DANGER,SIDE FRC 400N.....17
COIL,#8 20VDC,DEUTSCH W/DIODE.....83, 85	COVER, UPPER PIVOT.....53	DECAL,DANGER,TILT ALARM.....13-14
COIL,20VDC DEUTCSH W/DIODE.....83	COVER,BLANK.....74	DECAL,DANGER,TIP-OVER BATTERY.....13-14
COIL,24 VDC DUAL SPADE,#8.....83	COVER,CABLETRACK TRAY,Z40/45.....59	DECAL,DANGER,TIPOVER HAZARD***.....13-14
COMPR.LINK,MACHINED,GND CONTR*.....63	COVER,CENTER SWING CHASSIS.....35	DECAL,DRIVE ENABLE PATCH.....17
CONN PLUG 12 WAY ENDCAP DT BK.....40	COVER,CENTER SWING CHASSIS,PTD.....35	DECAL,FUNCTION OVERRIDE.....13-14, 17
CONN PLUG 12 WAY ENDCAP DT BR.....40	COVER,CONTROL BOX LEFT SIDE***.....97	DECAL,GROUND CONTROL PANEL.....13-14, 17
CONN PLUG 12 WAY ENDCAP DT GR.....40	COVER,CONTROL BOX RIGHT SIDE**.....97	DECAL,INSTR,MAX SIDE FRC,ANSI.....14
CONN PLUG 12 WAY ENDCAP DT GY.....40	COVER,GFCI,HORIZONTAL,WEATHER.....74	DECAL,INSTR,SIDE FRC/WIND,AUS.....13-14
CONN PLUG 4 WAY ENDCAP DT.....71	COVER,TANK SIDE,DC/BI.....47	D E C A L , I N S T R U C T , F O O T S W I T C H OPER.....13-14
CONN PLUG 8 WAY ENDCAP DT.....43	COVER,TURNTABLE,LH,BI-ENERGY.....45	DECAL,LABEL, AIR LINE 110 PSI.....13-14, 17
CONN PLUG 8 WAY MOLEX.....73-74	COVER,TURNTABLE,LH,DC/BE.....45	DECAL,LABEL,CONTRLR STATUS LT.....13-14
CONN RECEP,FLANGED.....73-74	COVR W/DECALS,NON-STEER Z45/25.....21-23	DECAL,LABEL,EMERGENCY DOWN.....17
CONN, 520120-6.....89, 91, 93	CUP,PROP ROD,DC/BI.....37	DECAL,LABEL,FALL HAZARD***.....17
CONN,520102-8-8.....89	CYLINDER,ELEVATE,Z45/25***.....51	DECAL,LABEL,LIGHTS***.....13-14, 17, 109
CONN,520120-12-10.....89	CYLINDER,EXTEND,Z45 NON JIB.....57	DECAL,LABEL,LOWER MIDRAIL.....14, 17
CONN,520120-4***.....93	CYLINDER,EXTEND,Z45J***.....57	DECAL,LABEL,MANUAL NOT HERE.....13-14
CONN,520120-4-6***.....83, 89, 91, 93	CYLINDER,JIB,Z45,#4 PORTS***.....63	DECAL,LABEL,MAX CAPACITY***.....17
CONN,520120-8-12.....89	CYLINDER,MASTER,Z45***.....55	DECAL,LABEL,OPEN,LATCH.....13-14
CONN,LONG,520122-6.....91, 93	CYLINDER,PRIM LIFT JIB,Z45.....55	DECAL,LABEL,PWR TO CHARGR 115V.....13-14
CONN,PLUG 120 AC/15A DOMESTIC.....35	CYLINDER,SLAVE,Z45***.....61, 63	DECAL,LABEL,PWR TO CHARGR 230V.....13-14
CONN,PLUG 24 WAY,DRC SERIES.....40	CYLINDER,STEER.....19	DECAL,LABEL,RELAYS,Z45DC,BE.....14
CONN,PLUG 4 WAY,12-14GA.....40		DECAL,LABEL,TIP OVER LMT SWITCH.....17
CONN,PLUG 40 WAY,DRC SERIES.....40		DECAL,LABEL,TIPOVER,BATTERIES.....17
CONN,PLUG 8WAY,BLOCKED GROMMET.....43		
CONN,RECEP 120AC/15A DOMESTIC.....35		
CONN,RECEP 24 WAY,W/FLANGE.....40		
CONN,RECEP 4 WAY,12-14GA FL***.....43, 73-74		
CONN,RECEP 40 WAY,W/FLANGE.....40, 43		
CONN,RECEP 48 WAY,4 X 12.....40, 43, 73-74		
CONN,RECEP 8 WAY 14-18GA,FL.....43		
CONN,SQUEEZE,1/2NPT .38-.50,SM.....35, 74		
CONNECTING LINK, Z45/25.....53		
CONTACT ALARM WIRE ASSY, LARGE.....115		
CONTACT, N.C.....39-40, 73-74		
CONTACT,MOVING,19549RELAY*.....21-23		
CONTACT,STATIONARY (56434)**.....22-23		
CONTACT,STATIONARY,19549RELAY*.....21-23		

D

DECAL KIT, Z45 DC & BI, WORDS.....13-14
 DECAL KIT,Z45 COMP,WORD,ANSI.....13-14
 DECAL KIT,Z45 COMP,WORD,AUS.....13-14
 DECAL KIT,Z45 DC & BI,SYMB.....17
 DECAL KIT,Z45 PLAT,SYM,ANSI.....17
 DECAL KIT,Z45 PLAT,SYM,CE.....17
 DECAL KIT,Z45 PLAT,WORD,ANSI.....13-14
 DECAL KIT,Z45 PLAT,WORD,AUS.....13-14
 DECAL KIT,Z45DC COMP,SYM,ANSI.....17
 DECAL KIT,Z45DC COMP,SYM,CE.....17
 DECAL PLATE ASSEMBLY.....71
 DECAL PLATE,MESH.....99
 DECAL, INSTR, OP INST,DC.....14

INPUT CARRIER, SUB-ASSEMBLY.....21-23
 INSTRN, TRC RETROFIT, STNDRD.....49
 INSULATION,48V BATT.BOX LID.....25
 INVERTER,48VDC,120VAC/60HZ.....33

J

JIB BOOM ASSY W/WORD DECAL.....67
 JOYSTICK,5K-0 OHM.....77
 JOYSTICK,5K-0 OHM,W/RELAY.....77
 JUMPER COMB, 2-WAY,WIELAND.....43

K

KEEPER,LATCH (45363).....45, 47
 KEY SINGLE***.....39-40
 KEY,SINGLE***.....39-40
 KEYS,10 PACK***.....39-40
 KEYSWITCH,3 POS W/KEYS,LOCKING.....39-40
 KEYSWITCH,3 POS. W/KEYS***.....39-40
 KIT, 24V SEP-EX DRIVE MOTORS.....22-23
 KIT, AUX TOP RAIL SUPPORT.....97
 KIT, BOOM BEARING.....51
 KIT, FOOTSWITCH, Z45 & Z51.....71
 KIT, ISOLATION, 3 JOYSTICK.....77
 KIT, LIFT GUARD CONTACT ALARM,6'-8' PLATFORM,NON-ALC1000.....115
 KIT, TERMINAL BLOCK.....43
 KIT, TRC RETROFIT, STNDRD.....49
 KIT, WIPER, Z-45/25J.....107
 KIT,ASSY,LED,IES CHARGER.....27
 KIT,ESTOP SVC BB&SM BOOM.....73-74
 KIT,FIELD INSTALL,SWING GATE.....99
 KIT,GASKET,UK POWER TO PLAT.....74
 KIT,HORN SVC BB&SM BOOM.....73-74
 KIT,LOAD SENSE MECH,Z45 JIB.....103
 KIT,SEAL,3CC PUMP***.....81
 KIT,SWING GATE W/SPRING.....99
 KIT,TORQUE HUB COVER(101584)**.....21-23
 KNOB, 45048 CONTROLLER.....79

L

LATCH, SWING GATE.....71
 LATCH,FLEXIBLE DRAW W/O KEEPER.....33, 45, 47
 LATCH,ROTARY, W/KNOB,LEFT.....25
 LATCH,ROTARY, W/KNOB,RIGHT.....25
 LATCH,SLIDE, FLUSH MOUNT STYLE.....97
 LEGEND,PLSTC,"CREEP TO 9"****.....79
 LENS,AMBER,STROBE,FIREBOLT.....95
 LEVEL SENSOR,LS60,YL,2.5X4.5.....33, 45
 LID ENCLOSURE,RED,OPA.....113
 LID-BATTERY BOX W/DECALS**.....25
 LIGHT, 12 VOLT.....97
 LIGHT,INDICATOR,RED 24V H-BRI.....43, 73-74
 LIGHT,INDICATOR,RED 28V.....73-74
 LINING KIT***.....21-23
 LINING KIT, BRAKE, 4HP***.....21-23
 LINK,NYLATRAC KS6-5.4***.....59
 LOAD PAD,ENGINE TRAY SUPPORT.....31
 LOAD SUPPORT WITH BEARINGS.....103
 LOCK,PLUG 12 WAY,14-18GA,GRN.....40
 LOCK,PLUG 4 WAY,12-14GA.....40
 LOCK,PLUG 8 WAY, 14-18GA.....43
 LOCK,RECEP 12 WAY, 14-18GA.....43, 73-74
 LOCK,RECEP 4 WAY,12-14GA.....40, 43, 73-74

LOCK,RECEP 4 WAY,14-18GA.....73-74
 LOCK,RECEP 8 WAY,14-18GA.....43
 LOCKNUT,ELEC,1/2".....35, 74
 LOWER LEVEL ARM ASSY***.....53
 LOWER SECONDARY ARM ASSY***.....53
 LS ROT.HEAD W/O LEVER (ZCE01).....31, 53
 LUG BOLT,5/8-18,WHEEL HUB***.....19
 LVI/BCI 36/48 VOLT ENGAGE II.....73-74

M

MAGNET, 1/4-20, 15 LB.....115
 MALE PIPE THD,1/4" SER,3/8"X18.....101
 MANIFOLD KIT, SW DRIVE.....31
 MANIFOLD,FUNCTION DC/BI***.....83
 MANIFOLD,JIB SELECT,20V***.....85
 MANIFOLD,ROTATOR,CB***.....61, 85
 MANIFOLD,TURNTABLE ROTATION***.....31
 MANUAL,AEM SAFETY.....11
 MANUAL,RESPON,A92.5 BOOM.....11
 MESH,HALF,LH 5' PLATFORM.....99
 MESH,HALF,LH,6' PLATFORM.....99
 MESH,HALF,RH 5' PLATFORM.....99
 MESH,HALF,RH,6' PLATFORM.....99
 MESH,HALF,SWING GATE***.....99
 MICROSWITCH,13482 FOOTSWITCH.....71
 MICROSWITCH,V3L-139-D8.....77
 MICROSWITCH-V319M***.....77
 MIDPIVOT ASSY Z45IC***.....53
 MODULE, PLUS+1, CONTACT ALARM.....115
 MODULE,CONTROL UNIT,PCB,OPA.....113
 MODULE,LOAD SENSE 2007.....43, 103
 MOTOR, 24V (36179).....33, 35
 MOTOR,FUNCTION,48V DC.....81
 MOTOR,SEP-EX,24V***.....22-23
 MOUNT,SWITCH.....103
 MOUNTING PLATE, 45048.....79
 MOVING CONTACT (FOR PN 74267).....21-23
 MPT,CPLR,1/4"SER,3/8"X18.....101

N

NECK/HEAD-LIMIT SWITCH (88356).....53
 NUT - PLASTIC,RING FOR ALARMS...35, 43, 73-74
 NUT, LP NYLOCK, 3/8-16.....37, 53, 61
 NUT,1/4-20,8,ZAG.....115
 NUT,JS,36867/42032/44988/40612.....77
 NUT,LOCKING-LG.FLANGE,5/16-18.....22-23
 NUT,LP NYLOCK,1/4-20.....97, 107
 NUT,LP NYLOCK,5/16-18.....25
 NUT,LUG,5/8-18 X 90 DEGREE,Z45.....19
 NUT,M4 NYLOCK.....113
 NUT,NYLOCK FLG,1/4-20,F,ZAG.....115
 NUT,NYLOCK FLG,3/8-16,F,ZAG.....111, 115
 NUT,NYLOCK,1/2-13.....31, 35
 NUT,NYLOCK,1/4-20.....22-23, 33, 37, 43, 45, 47, 53, 59, 61, 63, 65, 67, 97, 99, 103
 NUT,NYLOCK,10-24.....103
 NUT,NYLOCK,10-32.....31, 33, 43, 45, 47, 53, 109
 NUT,NYLOCK,3/4-10,GRD.8.....61, 65
 NUT,NYLOCK,3/8-16.....21-23, 27, 31, 33, 35, 37, 45, 51, 55, 59, 63, 67, 74, 103, 109
 NUT,NYLOCK,5/16-18.....22-23, 35, 65, 109
 NUT,NYLOCK,6-32.....115
 NUT,NYLOCK,8-32.....95
 NUT,RETAINER (96008).....39-40
 NUT,SERRATED,10-32,ZAG.....57, 115
 NUT,SPINDLE,1-14.....19

NUT,TL FLG,1/2-13,G,ZAG.....111
 NUT,TL FLG,1/4-20,G,ZAG.....57, 71, 113
 NUT,TL FLG,3/8-16,G,ZAG.....71, 113
 NUT-COIL SHORT.....85
 NUT-HEX,3M X 0.5MM.....77
 NUTSERT,1/4-20,STEEL CAD PLTD.....43
 NYLON WASHER,(36179).....33, 35

O

O-RING KIT (ORFS FITTINGS).....11, 87, 89, 91, 93
 O-RING KIT, AUSCO 1200 IN/LB.....21-23
 O-RING KIT,FIELD SVC,ALL PROD*.....11, 87, 89, 91, 93
 O-RING, ROTATOR MANIFOLD.....85
 O-RING,2-010,VITON.....21-23
 O-RING,END COVER,4HP/4HB***.....21-23
 O-RING,END COVER,OMNI***.....22-23
 O-RING,ORFS,-6.....39-40
 OPTION,EURO TOEBOARD.....97
 OPTION,PLAT,PINCH GUARD,4 FT.....97
 OPTION,PLAT,PINCH GUARD,5 FT.....97
 ORIFICE PLATE,0.037".....83
 ORIFICE PLUG, 0.060.....83
 ORIFICE PLUG,030,1/16-27 NPT.....83
 ORING,568-908 N552-90 NBR,10PK.....22-23
 OUTLET, 110V.....74

P

PAD,REST,1"THICK,W/STUDS*.....53
 PAD,REST,2"THICK,W/STUDS*.....35
 PAINT, AEROSOL, TRAFFIC BLACK.....11
 PAINT,AEROSOL,BRIGHT BLUE***.....11
 PAINT,AEROSOL,GENIE GRAY***.....11
 PAINT,WET,GENIE BLUE (1 GL)**.....11
 PAINT,WET,GENIE GRAY (1 GL)**.....11
 PAINT,WET,TRAFFIC BLACK (1 GL)**.....11
 PANEL,ACCESS PAINTED.....103
 PARKER DIGITAL PRESSURE GAUGE.....11
 PCB,ROTATOR CONTROLLER 36557*.....79
 PIN,0.75DIA X 5.75LG,CHAMFER.....103
 PIN,1.25 DIA X 3.19 LG, PLATE.....55
 PIN,1.25DIA X 14.45LG,2HOLE.....63
 PIN,1.25DIA X 3.37LG,1HOLE.....55
 PIN,1.25DIA X 5.25LG,1HOLE.....61, 63
 PIN,1.25DIA X 6.36LG,2RING.....57, 63
 PIN,1.25DIA X 7.00LG,1HOLE.....61, 63
 PIN,1.25DIA X 7.88LG,1HOLE.....63
 PIN,1.25DIA X 8.88LG,1HOLE.....61, 63
 PIN,1.25DIA X 9.38LG,2THREADED.....57
 PIN,1.50DIA X 13.88LG,2HOLE.....51
 PIN,1.50DIA X 20.00LG,CHAMFER.....19, 21-23
 PIN,1.50DIA X 4.25LG,GR/H.....19
 PIN,1.50DIA X 7.50LG,1HOLE***.....51
 PIN,1.75DIA X 11.88LG,CHAMFER.....55
 PIN,1.75DIA X 9.25LG,1HOLE.....55
 PIN,2.00DIA X 10.88LG,CHAMFER.....51
 PIN,2.00DIA X 12.88LG,CHAMFER***.....51
 PIN,2.00DIA X 24.00LG,CHAMFER***.....51, 55
 PIN,CLEVIS,1 X 2.5 LG.....19
 PIN,COTTER, 125 X 1.5.....19
 PIN,COTTER, 219 X 1.75.....19
 PIN,LOCK,SHORT***.....99
 PINCH GUARD,6"(1.31")SERVICE**.....97
 PIPE PLUG KIT,OMNI***.....22-23
 PLAT ASSY,6' W/SIDE GATE,Z45/51 ANSI SYM.....69
 PLAT ASSY,6' W/SIDE GATE,Z45/51 CE.....69

Part Description Index (continued)

PLAT ASSY,6' W/SIDE GATE,Z45DC/BI ANSI WORD.....69	RETAINING PIN, ASSY.....31	SCREW,HHC,5/16-18 X 1.25.....25, 35
PLAT ASSY,6' W/SIDE GATE,Z45DC/BI AUS.....69	RIVET,ALUM,ALUM,3/16BUTTONHEAD.....97	SCREW,HHC,5/8-11 X 2.75 GR8 BO.....31
PLAT CONTROL BOX W/DECAL.....73-74	RIVET,STEEL,P .25 X .375.....47, 99	SCREW,HHC,5/8-11 X 4.00 GR8 BO.....31
PLAT.ASSY,6FT,1/2 MESH, CE.....99	ROCKER ASSY (42032)***.....77	SCREW,HHC,5/8-11X4.50GR8 PLAIN.....31
PLATE, CABLE AND WIRE COVER.....115	ROCKER ASSY W/ROLLPIN***.....77	SCREW,HHF,1/2-13X3.5,8,ZAG.....111
PLATE, CONTACTOR MOUNT, Z45.....21-23	ROD END,.250 X 2.75 LG.....103	SCREW,HHF,1/4-20X.625,8,ZAG.....71
PLATE,COVER LATCH BACKING.....45, 47	ROD END,.375 X 2.25,ZAG.....55	SCREW,HHF,1/4-20X.75,8,ZAG.....71, 113, 115
PLATE,FOOT SWITCH COVER.....99	ROD END,.375X3.69,ZAG.....19, 21-23, 55, 57, 61, 63	SCREW,HHF,1/4-20X1.8,ZAG.....71
PLATE,FRONT COVER PAINTED.....35	ROD END.5 X 3.75,ZAG.....51, 55	SCREW,HHF,1/4-20X1.25,8,ZAG.....113
PLATE,JIB,ROTATE MANIFOLD.....65	ROD,DISCONNECT 4HP/4HB***.....21-23	SCREW,HHF,1/4-20X1.75,8,ZAG.....57
PLATE,SWING LOCK,PAINTED***.....31	ROD,DISCONNECT,OMNI***.....22-23	SCREW,HHF,10-24X.5.....115
PLATE,WIPER BACKING.....107	ROLLER ARM,LIMIT SWITCH***.....31, 53, 57	SCREW,HHF,3/8-16X1.8,ZAG.....71, 115
PLATFORM,1/2 MESH W/GATE,ANSI*.....99	ROTATIONAL CONTROLLER,24V***.....73-74, 79	SCREW,HHF,3/8-16X2.5,8,ZAG.....111
PLUG AND CAP KIT-SERVICE,37 **.....11, 87, 89, 91, 93	ROTATOR,PLAT,Z45.....61, 65	SCREW,HHF,M6-1.0X12,DIN6921,10.....113
PLUG AND CAP KIT-SERVICE,ORFS*.....11, 87, 89, 91, 93	ROTATOR,PLAT,Z45J/Z51J.....65	SCREW,HHTAPTITE THRED8-32X.38.....81
PLUG, TYPE F, 230A, 50HZ, 16A, IP44.....27, 35		SCREW,M5X16 BHD.....113
PLUG,090109A-6.....91, 93		SCREW,M6X8.....113
PLUG,3/4 MAGNETIC PIPE SQ.DRV.....37		SCREW,PHIL,10-24 X .75.....23
PLUG,BLANKING.....49		SCREW,PHIL,8-32X.50,SELF TAP.....74
PLUG,FUSED,250V,13AMP,U.K.**.....27, 35		SCREW,PHIL,PHM,10-24X1.5 ZINC.....103
PLUG,NYLON .38 BLACK DOMED.....39-40		SCREW,PHIL,PHM,10-32 X .5,SSTL.....43, 109
PLUG,NYLON .50 BLACK DOMED.....39-40, 73-74		SCREW,PHILLIPS,PHM,10-24 X 1.....22-23
PLUG,NYLON 1.12 BLACK DOMED.....73-74		SCREW,PHILLIPS,PHM,10-32 X .38.....22-23
PLUG,PWR,UK,16AMP,3PIN,BLK.....27, 35		SCREW,PHILLIPS,PHM,10-32 X .75.....33, 45, 47, 77
PLUG,SANTOPRENE .5 BLACK DOME.....39-40, 73-74		SCREW,PHILLIPS,PHM,10-32X 1.75.....53
PLUG,SEAL,12-18 GA.....43		SCREW,PHILLIPS,PHM,8-32 X 1.25.....95
POTENTIOMETER (56773).....77		SCREW,PHILLIPS,RHM,10-32 X 1.5.....31
POTENTIOMETER,56886.....79		SCREW,PHM,M3 X .5 X 12MM.....77
POWER RELAY, 24V COIL.....109		SCREW,PHM,M3.5 X 12MM (57890).....77
POWER UNIT,AUX PUMP 24VDC.....33, 35		SCREW,PHPM,10-24X1,ZAG.....71
PRIMARY BOOM ASSY.....59		SCREW,PHPM,10-32X1.25,ZAG.....115
PROGRAMMER, PMC 1313K-4401.....21-23		SCREW,PHPM,10-32X2,ZAG.....57
PROTECTOR,SLEW BOLT.....31		SCREW,PHPM,10-32X2.25,ZAG.....57
PROXIMITY SENSOR***.....49		SCREW,PHPM,6-32X.875,ZAG.....115
PUMP ASSEMBLY (36179).....33, 35		SCREW,SHC,1/2-13 X 3.00.....22-23, 31
PUMP,LIFT,3CC,CCW***.....81		SCREW,SHC,1/2-13 X 4.50 ZINC.....31
		SCREW,SHC,5/8-11 X 1.75.....21-23
		SCREW,SHC,5/8-11 X 2.75,A574.....31
		SCREW,SHC,5/8-11 X 4,A574.....31
		SCREW,SHC,5/8-11 X 4.5,A574.....31
		SCREW,THUMB,A-REG,3/8-16X1,ZAG.....25
		SEAL AND BRG KIT,4.5K ROTATOR.....61, 65
		SEAL AND BRG KIT,4.5K ROTATOR*.....61, 65
		SEAL DT SERIES-12W.....40
		SEAL KIT (39345).....63, 85
		SEAL KIT (54994).....63
		SEAL KIT CYL Z45 (54570).....57
		SEAL KIT CYL,Z45(54569).....57
		SEAL KIT, 37185 PUMP.....33, 35
		SEAL KIT, 88337.....19
		SEAL KIT, BRAKE, 4HP.....21-23
		SEAL KIT, OMNI.....22-23
		SEAL KIT, SWING DRIVE.....31
		SEAL KIT, VALVE.....83, 85
		SEAL KIT,147259.....63
		SEAL KIT,147260***.....55
		SEAL KIT,BRAKE***.....21-23
		SEAL KIT,CYL,Z45 (77187&77188).....55
		SEAL KIT,ELEVATE (88203).....51
		SEAL KIT,MANIFOLD TO MOTOR.....31
		SEAL KIT,MASTER & SLAVE CYL.....55, 61, 63
		SEAL KIT,SOLENOID VALVE, SV07.....85
		SEAL KIT,SWING DRIVE***.....31
		SEAL KIT,SWING MOTOR***.....31
		SEAL KIT, WHEEL DRIVE (106148/106445/107712).....21-23

S

SCREW 5/16-18 X .75 LG.FLG.LCK.....33
SCREW T-SWITCH PH/PH 6-32X1/4.....39-40, 73-74
SCREW, HCC, 3/8-16 X 1.50.....33, 35, 45, 55, 61, 63
SCREW,BHHS,1/4-20 X .5,Y/ZINC.....59
SCREW,BHHS,1/4-20 X .75.....59
SCREW,BHSC,1/4-20 X 1.....97
SCREW,BLEEDER,M5X0.8.....65
SCREW,FHM,10-32 X .75.....22-23
SCREW,FHS,3/8-16 X 1.75.....31
SCREW,HH TAPITITE THRD8-32X.50.....81
SCREW,HHC,1-8 X 3 GRD.5.....47
SCREW,HHC,1/2-13 X 1.25 GR5.....35, 37, 55
SCREW,HHC,1/2-13 X 1.5.....51, 53, 55
SCREW,HHC,1/4-20 X .5.....97
SCREW,HHC,1/4-20 X .625.....22-23, 53, 73-74, 97, 99
SCREW,HHC,1/4-20 X .75.....21-23, 37, 40, 63, 65, 67, 103
SCREW,HHC,1/4-20 X 1.....19, 25, 33, 37, 43, 45, 47, 53, 59, 61, 103
SCREW,HHC,1/4-20 X 1.25.....22-23, 45, 63, 67
SCREW,HHC,1/4-20 X 1.5.....61, 97
SCREW,HHC,1/4-20 X 1.75.....53
SCREW,HHC,1/4-20 X 2.....97, 103
SCREW,HHC,1/4-20 X 2.25.....47
SCREW,HHC,1/4-20 X 2.75.....61, 65
SCREW,HHC,1/4-20 X 3.....59
SCREW,HHC,1/4-20X1.75,8,ZAG.....57
SCREW,HHC,3/4-10 X 9.5 GR 8 YE.....61, 65
SCREW,HHC,3/8-16 X .75.....31, 33, 35, 37, 67
SCREW,HHC,3/8-16 X .75,GR 8.....65
SCREW,HHC,3/8-16 X 1.....19, 37, 53, 55, 109
SCREW,HHC,3/8-16 X 1.25 GRD 5.....19, 33, 61, 63, 74
SCREW,HHC,3/8-16 X 1.75,GRD.8.....45
SCREW,HHC,3/8-16 X 2.....67, 107
SCREW,HHC,3/8-16 X 2.25.....21-23
SCREW,HHC,3/8-16 X 2.75.....37, 51
SCREW,HHC,3/8-16 X 3.....27
SCREW,HHC,3/8-16 X 3.25.....103
SCREW,HHC,3/8-16X.75,8,ZAG.....57
SCREW,HHC,3/8-16X1.25,8,ZAG.....57
SCREW,HHC,3/8-16X1.75,8,ZAG.....57
SCREW,HHC,3/8-24 X 1 GR 8 YEL.....81
SCREW,HHC,5/16-18 X .75.....109
SCREW,HHC,5/16-18 X 1 GR5.....22-23, 35, 65, 97

Q

QUICK DISCONNECT CASING,BATT**.....29

R

RAILING CATCH CASTING--DRILLED.....99
RAILING,PINCH GAURD,4 FT.....97
RAILING,PINCH GAURD,5 FT.....97
RECEPTACLE,UK,110V.....74
Ref: Adjustable draw latch.....45
REF: Flashing Beacon.....49
REF: Foot Switch.....49
REF: Harness, Z45 Drive Lights.....97, 109
REF: Jib Platform rotator.....63
Ref: Swing Drive Assy (77082).....31
RELAY,24VDC,40/30A,SEALED***.....43, 73-74
RELAY,24VDC,40/30A,SLD W/BRKT*.....49, 77, 115
REPAIR END BRKT SET,NP400-7***.....59
REPAIR LINK END SET (42763)*.....59
REPAIR LINK,7 LINKS NP400-7***.....59
REPAIR LINK,7 LINKS***.....59
REPAIR LINK,NP400-7***.....59
RETAINER,SPRING,1.21 X .375.....103

SEAL KIT,WHEEL DRIVE W/BRAKE (101584/101585).....21-23	SWITCH TOGGLE ASSY SPDT 3P MOM...39-40, 73-74	V	VALVE - COUNTERBALANCE**.....85
SEAL MARKER, CROSS CHECK,BLUE,TUBE.....11	SWITCH TOGGLE DPDT 2P MOM SHDR.....40, 73-74		VALVE BLOCK, SWING DRIVE.....31
SEAL-GREASE,9-BOLT HUB 54840.....19	SWITCH TOGGLE DPDT 3P MOM SHDR.....39-40, 73-74		VALVE RELIEF,2500PSI(88513)**.....83
SENSOR,LEVEL,4.5 DEG.....33, 45	SWITCH TOGGLE SPDT 3P MOM SHDR.....39-40, 73-74		VALVE, CNTRBAL 3500 PSI, ATM VEN.....51
SENSOR,RUBBER EDGE.....113	SWITCH,LIMIT,W/RLLR ARM NO/NC.....53, 57		VALVE,3POSITION,4WAY*.....83
SERV KIT,HARN ASSY,PWR BATT PK.....29	SWITCH,LIMIT,W/RLLR ARM,NO/NC*.....53		VALVE,CB,CBBC-LHN@1000***.....57
SERVICE KIT, 5FT JIB.....63	SWITCH,LIMIT,W/RLR ARM,NO/NC**.....31		VALVE,CHECK (36179).....33, 35
SERVICE KIT,5FT JIB.....67	SWITCH,LOAD LIMIT.....103		VALVE,CHECK,DUAL PILOT***.....83
SET SCREW**.....21-23	SWITCH,PRESS,#6SAE,600 PSI.....83		VALVE,CHK,#8PORT-#8MALEORFS.....89
SHAFT ASSY, JOYSTICK***.....77	S W I T C H , T O G G L E , S P D T , 3 P O S M O M E N *73-74		VALVE,COUNTERBALANCE,3500***.....61, 63
SHIM,AXLE ROTATION STOP,12GA.....22-23		T	VALVE,COUNTERBALANCE,3800 PSI.....55
SHIM,AXLE ROTATION STOP,22GA.....22-23			VALVE,COUNTERBALANCE,3800 PSI*.....55, 63
SHIM,SIDE PAD 22GA.....57			VALVE,COUNTERBALANCE,1500 PSI**.....57
SHIM,WEAR PAD,5X 1.5 16GA.....57			VALVE,DIRECTIONAL,2-WAY,3 POS.....83
SHIM,WEAR PAD,5X 1.5,14GA,HOLE.....57			VALVE,FLOW CONTROL,,4 GPM.....83
SHRINK TUBE, BLACK 3/4,3:1.....29			VALVE,NEEDLE,FINE ADJUSTMENT**.....83
SLEEVE,NYLON, 2" ID.....93	T-BOX,2.75 X 4.5 X 2.0.....74		VALVE,PRESS COMP,PROP DIRECT.....83
SLEEVE,NYLON,1.42 ID.....91, 93	TANK BREATHER,NYLON **.....37		VALVE,RELIEF,2100 PSI***.....83
SLEEVE,NYLON,2" I.D.,BULK(100').....91	TANK,HYDRAULIC,8 GALLON,DC/BI.....37		VALVE,SHUTTLE.....83
SLEEVE,NYLON,3.13 ID.....91	TAPE, PROTECTIVE MASK.....17		VALVE,SOLENOID 3 POS.4 WAY***.....83
SLIDING MIDRAIL KIT,PTD.....71	TAPE,WARNING,BLK/YEL, 50***.....13-14, 17		VALVE,SOLENOID, 2POS/3WAY***.....83, 85
SNAP RING,EXTERNAL,1.25,ZAG.....57, 63	TEE,BRANCH,520429-6.....91, 93		VALVE-CHECK, #4 SAE, 5 PSI*.....83
SNAP RING,EXTERNAL,1.50,ZAG.....19	TEE,BRANCH,520433-8.....89		VALVE-RELIEF,3200 PSI.....83
SNAP RING,WHEEL DRIVE.....21-23	TEE,RUN,520428-4.....87		VALVE-SOLENOID,2POS 3WAY,JIB**.....85
SOUNDER LENS, OPA, AMBER.....113	TERM,DEUTSCH, PIN #12-14.....73-74		
SOUNDER LENS, OPA, BLUE.....113	TERM,NI PIN, 14-16GA,BULK.....73-74		
SOUNDER LENS, OPA, CLEAR.....113	TERM,NI PIN,S&F,16-18GA,REEL.....73-74		
SOUNDER LENS, OPA, RED.....113	TERM.BUSS,10POLE,JOYSTICK56773.....77		
SOUNDER,MIDI,OPA.....113	TERMINAL BLOCK END PLATE.....43		
SPACER TUBE, .50 LG.....107	TERMINAL BLOCK, WIELAND***.....43		
SPACER, HANGER BRACKET.....111	TERMINAL BLOCK, WIELAND.....43		
SPACER,HEAT SINK.....113	TIE ROD WELDMENT, NARROW.....19		
SPACER,HOSE CLAMP,RUBBER.....59	TIME DELAY RELAY,2 SEC,24VDC.....73-74		
SPACER,NYLON,2.00 X 1.33 X.310.....57	TIRE/WH ASSY,9 LG,FOAM,NS REAR.....22-23		
SPACER,NYLON,2.01 X 1.28 X.135.....57	TIRE/WH ASSY,9 LG,FOAM,S FRONT.....19		
SPACER-POT.PLATE,JOYSTICK56773.....77	TIRE/WH ASSY,9 LG,NM,FOAM,S FR.....19		
SPRING & BUSHING KIT,RETURN***.....77	TIRE/WH ASSY,9 LG,NM,REPNEU,NS.....22-23		
SPRING CLIP,1/4-20, 025-.15X.54,ZAG.....19, 21-23, 63, 67, 71, 103	TIRE/WH ASSY,9 LG,NM,REPNEU,S.....19		
SPRING CLIP,10-24, 025-.125X.468,ZAG...22-23, 71, 115	TIRE/WH ASSY,9 LG,REPNEU,NS.....22-23		
SPRING CLIP,3/8-16, .05-.20X.73,ZAG.....25	TIRE/WH ASSY,9 LG,REPNEU,S.....19		
SPRING, BRUSH RETAINER, 36182*.....22-23	TIRE/WH ASSY,9LG,NM,FOAM,NS RE.....19, 22-23		
SPRING, RETURN (FOR 74267).....21-23	TOEBOARD,ENTRY EUROPEAN PNTD**.....71, 97		
SPRING, RETURN (FOR 74268).....21-23	TOOL TRAY ACCESSORY***.....97		
SPRING,COMP,1" OD,232 LB/IN.....103	TOOL,TERMINAL CRIMPER,MOLEX***.....21-23		
SPRING,RETURN (74266).....22-23	TOOL,TERMINAL EXTRACTOR,MOLEX...21-23		
SPRING,SHORT PLATFORM GATE.....99	TRIMLOCK,BLACK,3/16 X 4 INCHES.....53		
SPRING-BRUSH,40844, SCISSORS.....81	TROLLEY, TRACK, FALL ARREST BAR.....111		
STACK KIT, AUSCO 1200 IN/LB.....21-23	TUBE, CABLETRACK ARM, Z40/45.....59		
STAND OFF,CONTROL UNIT.....113	TUBE,PLASTIC .5 NPT X 18".....37		
STANDOFF, 3/8" BLACK.....33	TUBE,PROP ROD,12.25"LG,DC/BI.....47		
STEP PLATFORM ENTRY PAINTED***.....71	TUBE,PROP ROD,18.63",W/CAP.....47		
STRAINER ASSEMBLY,1.25" NPT***.....37, 89	TUBE,RD,STL,DOM,.75X.438X1.25.....107		
STRAP ASSY,29.25LG,W/RUBBER.....37		U	
STROBE,FIREBOLT,12-80VDC,AMB**.....95			U-BOLT, FLATTENED, 1.5 X 3/8 UNC,ZAG.....113
STRUT,GAS,200 LB***.....45			UPPER LEVEL ARM ASSY,SERV***.....53
STUD,POWER 3/8" RED.....33			UPPER PIVOT W/BEARING-Z45/25**.....55
SUPPORT, RAILING.....97			UPPER SECONDARY ARM ASSY-Z45**.....53
SWING DRIVE ASSEMBLY.....31			
SWING DRIVE ASSY*** (147209).....31			
SWITCH TOGGLE ASSY DPDT 2P MOM.40, 73-74			
SWITCH TOGGLE ASSY DPDT 3P MOM...39-40, 73-74			
SWITCH TOGGLE ASSY SPDT 2P MNT....109			

Part Description Index (continued)

WEAR PAD,4.88 X 1.5 X .5.....37
 WEAR PAD,4X2X.5 W/INSERT***25
 WEAR PAD,5 X 1.5 X .625 W/NUTS.....57
 WEAR PAD,5 X 1.5 X .75 W/NUTS.....57
 WEAR PAD,6 X 1.5 X .50,W/INSERT.....53
 WEAR PAD,EXTENSION BOOM.....57
 WEAR PAD,EXTENSION CYLINDER.....57
 WEAR PAD,MID PIVOT***53
 WEAR PAD,PRIMARY BOOM,JIB.....57
 WEAR PAD,PRIMARY BOOM,NON JIB.....35
 WELDMENT, CABLETRACK TRAY.....59
 WELDMENT, EXT. BOOM,Z45 NJ.....57
 WELDMENT, LEFT CONTACT ALARM,
 LARGE.....115
 WELDMENT, RIGHT CONTACT ALARM,
 LARGE.....115
 WELDMENT, Z45 PLATFORM SUPPORT, NO
 JIB.....71
 WELDMENT,4 FT PLATFORM.....69
 WELDMENT,5 FT PLATFORM.....69
 WELDMENT,EXT. BOOM,Z45 JIB.....57
 WELDMENT,MID PIVOT,MACHINED***53
 WELDMENT,PLATFORM SUPPORT....65, 103
 WELDMENT,PRIMARY BOOM,Z45 JIB.....57
 WELDMENT,PRIMARY BOOM,Z45NJ.....57
 WELDMENT,ROTATOR MOUNT.....103
 WELDMENT,SWING GATE,ALUMINUM.....99
 WELDMNT,6 FT PLATFORM.....69
 WELDMNT,PLATFRM SUPPORT,NJIB**61
 WHEEL DRIVE, NON-BRAKE, 47.6:1.....22-23
 WHEEL DRIVE,4HB,48:1***.....21-23
 WHEEL STUD, 4HP, 5/8-18***.....21-23
 WHEEL STUD,5/8-18,OMNI***22-23
 WIPER,PRIMARY BOOM.....107
 WIRE ASSY #10 RED F1/F2.....29
 WIRE ASSY #10 RED F2/F1.....29
 WIRE CABLE,14/3 CON.TPE JKT*.....35
 WIRE CABLE,16/4 CON.TPE JKT.....53, 71
 WIRE LOOM,1.25"NYLON,HIGH TEMP.....57,
 61, 63
 WIRE,12/3 SJEOW,BK-WH-GR/YL.....49
 WORKLIGHT,110V,250WATT,HALOGEN.....97
 WORKLIGHT,48 VOLT.....97, 109

Y

YOKE ASSY.LH'2WD'Z45IC.....19
 YOKE ASSY.RH'2WD'Z45IC.....19

Z

ZERK,GREASE,5/16-24,STRAIT..... 103

— GENERAL SERVICE PARTS —.....11
 — MANUALS —.....11

This Page Intentionally Left Blank

Fitting Cross References

Genie PN	Parker PN	Description	Genie PN	Parker PN	Description
12342	6-4 F5OX-S	CONNECTOR, STRAIGHT THREAD TO FLARE TUBE	42794	1 CR-S	ELBOW, 90°, MALE PIPE
13757	4 R6X-S	RUN TEE, SWIVEL NUT, ORFS	42795	BV-0839	BALL VALVE
19685	12-10 C5OX-S	ELBOW, 90°, STRAIGHT THREAD TO FLARE TUBE	42796	BV-0838	BALL VALVE
22664	12-10 C5OX	ELBOW, 90°, STRAIGHT THREAD TO FLARE TUBE	42874	6-8 CLO-S	ELBOW, 90°, MALE PIPE TO ORFS
27431	8-12 F5OX-S	CONNECTOR, STRAIGHT THREAD TO FLARE TUBE	42912	13943-6-4	HOSE END, 90° FEMALE SWIVEL, JIC
28678	AS-B-33	SLEEVE, NYLON, 1.81" ID	42920	BV-0840	BALL VALVE, 90°
39871	6 WETX-WLN-S	UNION, 90° BULKHEAD W/NUT, FLARE TUBE	42932	AS-B-17	SLEEVE, NYLON, 1.22" ID
39872	4 R5OX-S	RUN TEE, STRAIGHT THREAD	42936	10243-2-4	HOSE END, FEMALE PIPE
39873	6 C5OX-S	ELBOW, 90°, STRAIGHT THREAD TO FLARE TUBE	42953	1/2 DD-S	ELBOW, 90°, FEMALE PIPE
39874	8-6 C5OX-S	ELBOW, 90°, STRAIGHT THREAD TO FLARE TUBE	42956	6 WELO-WLNL-S	UNION, 90° BULKHEAD W/NUT, ORFS
39875	4-6 C5OX-S	ELBOW, 90°, STRAIGHT THREAD TO FLARE TUBE	45349	8 V5OX-S	ELBOW, 45°, STRAIGHT THREAD TO FLARE TUBE
39876	6-8 C5OX-S	ELBOW, 90°, STRAIGHT THREAD TO FLARE TUBE	45351	4 V5OX-S	ELBOW, 45°, STRAIGHT THREAD TO FLARE TUBE
39877	4 F5OX-S	CONNECTOR, STRAIGHT THREAD TO FLARE TUBE	47223	10343-6-6	HOSE END, MALE, JIC
39878	6 F5OX-S	CONNECTOR, STRAIGHT THREAD TO FLARE TUBE	47419	PS690503-6-6	SWIVEL, 90°, STRAIGHT THREAD TO 37° FLARE
39879	4-8 F5OX-S	CONNECTOR, STRAIGHT THREAD TO FLARE TUBE	48750	421-4	HOSE, 1/4 INCH ID
39880	6-10 F5OX-S	CONNECTOR, STRAIGHT THREAD TO FLARE TUBE	48751	481TC-4	HOSE, 1/4 INCH ID
39881	4-6 F5OX-S	CONNECTOR, STRAIGHT THREAD TO FLARE TUBE	48752	482TC-4	HOSE, 1/4 INCH ID
39882	4-HP5ON-S	PLUG, STRAIGHT THREAD	48753	451TC-6	HOSE, 3/8 INCH ID
39883	8-8 FTX-S	CONNECTOR, MALE PIPE TO FLARE TUBE	48754	482TC-6	HOSE, 3/8 INCH ID
39885	269HB 12-12	ELBOW, 90°, BEADED HOSE BARB TO MALE PIPE	48755	381-6	HOSE, 3/8 INCH ID
39886	431-6	HOSE, 3/8 INCH ID	48756	451TC-8	HOSE, 1/2 INCH ID
39887	540N-2	HOSE, 1/8 INCH ID	48757	482TC-8	HOSE, 1/2 INCH ID
39888	801-8	HOSE, 1/2 INCH ID	48758	381-8	HOSE, 1/2 INCH ID
39889	801-12	HOSE, 3/4 INCH ID	48759	381-10	HOSE, 5/8 INCH ID
39890	10643-6-6	HOSE END, FEMALE SWIVEL, JIC	48760	451TC-10	HOSE, 5/8 INCH ID
39891	13943-6-6	HOSE END, 90° FEMALE SWIVEL, JIC	48761	482TC-12	HOSE, 3/4 INCH ID
39892	13743-6-6	HOSE END, 45° FEMALE SWIVEL, JIC	48762	451TC-12	HOSE, 3/4 INCH ID
39894	30682-8-8	HOSE END, FEMALE SWIVEL, JIC	48763	772-12	HOSE, 3/4 INCH ID
39895	30682-10-12	HOSE END, FEMALE SWIVEL, JIC	48764	881-16	HOSE, 1 INCH ID
42286	8-8 CTX-S	ELBOW, 90°, MALE PIPE TO FLARE TUBE	48765	772-16	HOSE, 1 INCH ID
42756	8-12 CLO-S	ELBOW, 90°, MALE PIPE TO ORFS	48766	AS-B-15	SLEEVE, NYLON, 1.06" ID
42757	8-12 FLO-S	CONNECTOR, MALE PIPE TO ORFS	48767	AS-B-22	SLEEVE, NYLON, 1.42" ID
42758	4 JLO-S	UNION TEE, ORFS	48770	881-8	HOSE, 1/2 INCH ID
42759	4-4 FLO-S	CONNECTOR, MALE PIPE TO ORFS			
42760	6-8 FLO-S	CONNECTOR, MALE PIPE TO ORFS			
42761	1J143-6-4	HOSE END, 90° FEMALE SWIVEL, SEAL LOK			
42762	1J743-6-4	HOSE END, 45° FEMALE SWIVEL, SEAL LOK			
42768	1JO43-4-4	HOSE END, MALE, SEAL LOK			
42776	601-8	HOSE, 1/2 INCH ID			
42777	1J743-16-16	HOSE END, 45° FEMALE SWIVEL, SEAL LOK			
42786	16 CLO-S	ELBOW, 90°, MALE PIPE TO ORFS			
42787	16 R6LO-S	RUN TEE, SWIVEL NUT, ORFS			
42788	16-8 TRLO-BL-S	REDUCER, TUBE END TO SWIVEL, ORFS			
42789	6-6 CLO-S	ELBOW, 90°, MALE PIPE TO ORFS			
42790	8-10 V5OLO-S	ELBOW, 45°, STRAIGHT THREAD TO ORFS			
42791	3/4 CD-S	ELBOW, 90°, MALE TO FEMALE PIPE			
42792	3/4 X 1/2 PTR-S	REDUCER, MALE TO FEMALE PIPE			
42793	1/2 CR-S	ELBOW, 90°, MALE PIPE			

Fitting Cross References (Continued)

Genie PN	Parker PN	Description	Genie PN	Parker PN	Description
48771	881-10	HOSE,5/8 INCH ID	48847	13943-12-12	HOSE END,90° FEMALE SWIVEL,JIC
48772	381-4	HOSE,1/4 INCH ID	48848	10543-12-12	HOSE END,MALE,STRAIGHT THREAD
48773	AS-B-13	SLEEVE,NYLON,.86" ID	48849	1JC71-12-12	HOSE END,FEMALE SWIVEL,SEAL LOK
48800	1JC43-4-4	HOSE END,FEMALE SWIVEL,SEAL LOK	48850	1JS71-12-12	HOSE END,FEMALE SWIVEL,SEAL LOK
48801	1J743-4-4	HOSE END,45° FEMALE SWIVEL,SEAL LOK	48851	1J171-12-12	HOSE END,90° FEMALE SWIVEL,SEAL LOK
48802	1J943-4-4	HOSE END,90° FEMALE SWIVEL,SEAL LOK	48852	1J771-12-12	HOSE END,45° FEMALE SWIVEL,SEAL LOK
48804	1JM43-4-4	HOSE END,MALE,SEAL LOK, NO O-RING	48853	1J971-12-12	HOSE END,90° FEMALE SWIVEL,SEAL LOK
48805	10643-4-4	HOSE END,FEMALE SWIVEL,JIC	48854	1JC43-16-16	HOSE END,FEMALE SWIVEL,SEAL LOK
48806	13943-4-4	HOSE END,90° FEMALE SWIVEL,JIC	48855	1J943-16-16	HOSE END,90° FEMALE SWIVEL,SEAL LOK
48807	1JS43-4-4	HOSE END,FEMALE SWIVEL,SEAL LOK	48856	1J171-16-16	HOSE END,90° FEMALE SWIVEL,SEAL LOK
48808	3JC82-8-8	HOSE END,FEMALE SWIVEL,SEAL LOK	48857	1J971-16-16	HOSE END,90° FEMALE SWIVEL,SEAL LOK
48809	3JC82-12-12	HOSE END,FEMALE SWIVEL,SEAL LOK	48859	1JS43-8-4	HOSE END,FEMALE SWIVEL,SEAL LOK
48810	1JC43-6-4	HOSE END,FEMALE SWIVEL,SEAL LOK	48867	PD36BTL	DIAGNOSTIC NIPPLE,SEAL-LOK SWIVEL
48811	1J943-6-4	HOSE END,90° FEMALE SWIVEL,SEAL LOK	48873	6 PNLO-S	PLUG,TUBE END,ORFS
48812	1JC43-6-6	HOSE END,FEMALE SWIVEL,SEAL LOK	48874	6 PNTX-S	PLUG,FLARE TUBE
48813	1J143-6-6	HOSE END,90° FEMALE SWIVEL,SEAL LOK	48875	6 R6LO-S	RUN TEE,SWIVEL NUT,ORFS
48814	1J543-6-6	HOSE END,90° FEMALE SWIVEL,SEAL LOK	48877	4 F5OLO-SW/.025	CONNECTOR,STRAIGHT THREAD TO ORFS, W/.025 ORI
48815	1J743-6-6	HOSE END,45° FEMALE SWIVEL,SEAL LOK	48878	16-12 C5OLO-S	ELBOW,90°,STRAIGHT THREAD TO ORFS
48816	1J943-6-6	HOSE END,90° FEMALE SWIVEL,SEAL LOK	48879	8 C6LO-S	ELBOW,90°,SWIVEL NUT ORFS
48817	1JS43-6-8	HOSE END,FEMALE SWIVEL,SEAL LOK	48880	PD6-285	CAP,DIAGNOSTIC NIPPLE
48818	1J943-8-4	HOSE END,90° FEMALE SWIVEL,SEAL LOK	48881	6 HLO-S	UNION,ORFS
48819	1JC43-8-6	HOSE END,FEMALE SWIVEL,SEAL LOK	48883	8 P5ON-S	PLUG,STRAIGHT THREAD
48820	1J743-8-6	HOSE END,45° FEMALE SWIVEL,SEAL LOK	48884	8M18F87OMLO-S	CONNECTOR,METRIC,STRAIGHT THREAD TO ORFS
48821	1J943-8-6	HOSE END,90° FEMALE SWIVEL,SEAL LOK	48885	4 WGTX-WLN-S	CONNECTOR,BULKHEAD,FEMALE PIPE TO FLARE TUBE
48822	1JC43-8-8	HOSE END,FEMALE SWIVEL,SEAL LOK	48886	4 F5OLO-SW/2MM	CONNECTOR,MACHINED STRAIGHT THREAD TO ORFS
48823	1JS43-8-8	HOSE END,FEMALE SWIVEL,SEAL LOK	48887	4 CTX-S	ELBOW,90°,MALE PIPE TO FLARE TUBE
48824	1J143-8-8	HOSE END,90° FEMALE SWIVEL,SEAL LOK	48888	10-12 V5OLO-S	ELBOW,45°,STRAIGHT THREAD TO ORFS
48825	1J543-8-8	HOSE END,90° FEMALE SWIVEL,SEAL LOK	48890	4 S5OLO-S	BRANCH TEE,STRAIGHT THREAD TO ORFS
48826	1J743-8-8	HOSE END,45° FEMALE SWIVEL,SEAL LOK	48891	4 S6LO-S	BRANCH TEE,SWIVEL NUT TO ORFS
48827	1J943-8-8	HOSE END,90° FEMALE SWIVEL,SEAL LOK			
48828	1JC43-10-8	HOSE END,FEMALE SWIVEL,SEAL LOK			
48829	1JS43-10-8	HOSE END,FEMALE SWIVEL,SEAL LOK			
48830	1J743-10-8	HOSE END,45° FEMALE SWIVEL,SEAL LOK			
48831	1J943-10-8	HOSE END,90° FEMALE SWIVEL,SEAL LOK			
48833	1JC43-10-10	HOSE END,FEMALE SWIVEL,SEAL LOK			
48834	1J943-10-10	HOSE END,90° FEMALE SWIVEL,SEAL LOK			
48835	1JS43-10-12	HOSE END,FEMALE SWIVEL,SEAL LOK			
48836	1JC43-12-8	HOSE END,FEMALE SWIVEL,SEAL LOK			
48837	1JS43-12-8	HOSE END,FEMALE SWIVEL,SEAL LOK			
48838	1J743-12-8	HOSE END,45° FEMALE SWIVEL,SEAL LOK			
48839	1J943-12-8	HOSE END,90° FEMALE SWIVEL,SEAL LOK			
48840	1J943-12-10	HOSE END,90° FEMALE SWIVEL,SEAL LOK			
48841	1JC43-12-12	HOSE END,FEMALE SWIVEL,SEAL LOK			
48842	1JO43-12-12	HOSE END,MALE,SEAL LOK			
48843	1J143-12-12	HOSE END,90° FEMALE SWIVEL,SEAL LOK			
48844	1J543-12-12	HOSE END,90° FEMALE SWIVEL,SEAL LOK			
48845	1J743-12-12	HOSE END,45° FEMALE SWIVEL,SEAL LOK			
48846	1J943-12-12	HOSE END,90° FEMALE SWIVEL,SEAL LOK			

Fitting Cross References (Continued)

Genie PN	Parker PN	Description	Genie PN	Parker PN	Description
48892	6 C6LO-S	ELBOW,90°,SWIVEL NUT ORFS	48938	8 R6LO-S	RUN TEE,SWIVEL NUT,ORFS
48893	6 F5OHAO-S	UNION,STRAIGHT THREAD	48939	8 S6LO-S	BRANCH TEE,SWIVEL NUT TO ORFS
48894	8 WLO-WLNL-S	UNION,BULKHEAD,ORFS	48940	8 WJLO-WLNL-S	RUN TEE, BULKHEAD,ORFS
48895	DT-370-MSMO-5	VALVE,CHECK	48941	8-4 TRLO-S	REDUCER,TUBE END TO SWIVEL,ORFS
48896	6 JLO-S	UNION,TEE,ORFS	48942	8-6 C5OLO-S	ELBOW,90°,STRAIGHT THREAD TO ORFS
48897	DT-750-MSMS-5	VALVE,CHECK	48943	8-6 F5OLO-S	CONNECTOR,STRAIGHT THREAD TO ORFS
48898	DT-750-MOMS-5	VALVE,CHECK	48944	8-8 FLO-S	CONNECTOR,MALE PIPE TO ORFS
48899	DT-620-MOMS-5	VALVE,CHECK	48945	8 FTX-S	CONNECTOR,MALE PIPE TO FLARE TUBE
48900	4-6 F5OLO-SW/.035	CONNECTOR,STRAIGHT THREAD TO ORFS, W/.035 ORI	48946	8-10 F5OLO-S	CONNECTOR,STRAIGHT THREAD TO ORFS
48902	16-1 AOE4G-S	ELBOW,90° LONG,FEMALE PIPE TO STRAIGHT THREAD	48947	8-12 C5OLO-S	ELBOW,90°,STRAIGHT THREAD TO ORFS
48903	1 FF-S	NIPPLE,PIPE	48948	8-12 F5OLO-S	CONNECTOR,STRAIGHT THREAD TO ORFS
48904	4 C5OLO-S	ELBOW,90°,STRAIGHT THREAD TO ORFS	48949	8-16 F5OLO-S	CONNECTOR,STRAIGHT THREAD TO ORFS
48905	4 F5OLO-S	CONNECTOR,STRAIGHT THREAD TO ORFS	48950	10 C5OLO-S	ELBOW,90°,STRAIGHT THREAD TO ORFS
48906	4 R5OLO-S	RUN TEE,STRAIGHT THREAD	48951	10 CC5OLO-S	ELBOW,90° LONG,STRAIGHT THREAD TO ORFS
48907	4 V5OLO-S	ELBOW,45°,STRAIGHT THREAD TO ORFS	48952	10 F5OLO-S	CONNECTOR,STRAIGHT THREAD TO ORFS
48908	4 R6LO-S	RUN TEE,SWIVEL NUT,ORFS	48953	10 R5OLO-S	RUN TEE,STRAIGHT THREAD
48909	4 WJLO-WLNL-S	RUN TEE, BULKHEAD,ORFS	48954	10 S5OLO-S	BRANCH TEE,STRAIGHT THREAD TO ORFS
48910	4 GTX-S W/.030	CONNECTOR,FEMALE PIPE TO FLARE TUBE	48955	10 R6LO-S	RUN TEE,SWIVEL NUT,ORFS
48911	4-6 C5OLO-S	ELBOW,90°,STRAIGHT THREAD TO ORFS	48956	10-4 TRLO-BL-S	REDUCER,TUBE END TO SWIVEL,ORFS
48912	4-6 F5OLO-S	CONNECTOR,STRAIGHT THREAD TO ORFS	48957	10-6 TRLO-BL-S	REDUCER,TUBE END TO SWIVEL,ORFS
48913	4-6 F5OLO-SW/.030	CONNECTOR,STRAIGHT THREAD TO ORFS, W/.030 ORI	48958	10-12 F5OLO-S	CONNECTOR,STRAIGHT THREAD TO ORFS
48914	4-8 F5OLO-S	CONNECTOR,STRAIGHT THREAD TO ORFS	48959	12 C5OLO-S	ELBOW,90°,STRAIGHT THREAD TO ORFS
48915	6 C5OLO-S	ELBOW,90°,STRAIGHT THREAD TO ORFS	48960	12 F5OLO-S	CONNECTOR,STRAIGHT THREAD TO ORFS
48916	6 F5OLO-S	CONNECTOR,STRAIGHT THREAD TO ORFS	48961	12 R5OLO-S	RUN TEE,STRAIGHT THREAD
48917	6 FF5OLO-S	CONNECTOR,LONG,STRAIGHT THREAD TO ORFS	48962	12 S5OLO-S	BRANCH TEE,STRAIGHT THREAD TO ORFS
48918	6 R5OLO-S	RUN TEE,STRAIGHT THREAD	48963	12 V5OLO-S	ELBOW,45°,STRAIGHT THREAD TO ORFS
48919	6 S5OLO-S	BRANCH TEE,STRAIGHT THREAD TO ORFS	48964	12 R6LO-S	RUN TEE,SWIVEL NUT,ORFS
48920	6 V5OLO-S	ELBOW,45°,STRAIGHT THREAD TO ORFS	48965	12 CLO-S	ELBOW,90°,MALE PIPE TO ORFS
48921	6 FLO-S	CONNECTOR,MALE PIPE TO ORFS	48966	12 FLO-S	CONNECTOR,MALE PIPE TO ORFS
48922	6-6 FLO-S	CONNECTOR,MALE PIPE TO ORFS	48967	12 JLO-S	UNION TEE,ORFS
48923	6 P5ON-S	PLUG,STRAIGHT THREAD	48968	12 WLO-WLNL-S	UNION,BULKHEAD,ORFS
48925	6 WELO-S	UNION,90° BULKHEAD,ORFS	48969	12 WJLO-WLNL-S	RUN TEE, BULKHEAD,ORFS
48926	6-4 C5OLO-S	ELBOW,90°,STRAIGHT THREAD TO ORFS	48970	12 WELO-WLNL-S	UNION,90° BULKHEAD W/NUT,ORFS
48927	6-4 F5OLO-S	CONNECTOR,STRAIGHT THREAD TO ORFS			
48928	6-4 V5OLO-S	ELBOW,45°,STRAIGHT THREAD TO ORFS			
48929	6-8 C5OLO-S	ELBOW,90°,STRAIGHT THREAD TO ORFS			
48930	6-8 F5OLO-S	CONNECTOR,STRAIGHT THREAD TO ORFS			
48931	6-10 F5OLO-S	CONNECTOR,STRAIGHT THREAD TO ORFS			
48932	8 C5OLO-S	ELBOW,90°,STRAIGHT THREAD TO ORFS			
48933	8 F5OLO-S	CONNECTOR,STRAIGHT THREAD TO ORFS			
48934	8 FF5OLO-S	CONNECTOR,LONG,STRAIGHT THREAD TO ORFS			
48935	8 R5OLO-S	RUN TEE,STRAIGHT THREAD			
48936	8 S5OLO-S	BRANCH TEE,STRAIGHT THREAD TO ORFS			
48937	8 V5OLO-S	ELBOW,45°,STRAIGHT THREAD TO ORFS			

Fitting Cross References (Continued)

Genie PN	Parker PN	Description	Genie PN	Parker PN	Description
48971	12 G5G5JG5-S	TEE,FEMALE STRAIGHT THREAD	49612	PKT02586	O-RING KIT (ORFS FITTINGS)
48972	12 XHL6-S	ADAPTER, 37° MALE TO SWIVEL ORFS	49613	PKT06276	PLUG AND CAP KIT-SERVICE,ORFS
48973	12-1/2 F5OG-S	ADAPTER,FEMALE PIPE TO STRAIGHT THREAD	49728	10143-12-12	HOSE END, MALE PIPE
48974	12-10 C5OLO-S	ELBOW,90°,STRAIGHT THREAD TO ORFS	49729	16-1 F5OG-S	ADAPTER,FEMALE PIPE TO STRAIGHT THREAD
48975	12-10 F5OLO-S	CONNECTOR,STRAIGHT THREAD TO ORFS	49814	12-8 FLO-S	CONNECTOR,MALE PIPE TO ORFS
48976	12-16 C5OLO-S	ELBOW,90°,STRAIGHT THREAD TO ORFS	49829	DT-500-MOMF-5	VALVE,CHECK
48977	12-16 F5OLO-S	CONNECTOR,STRAIGHT THREAD TO ORFS	49831	881-12	HOSE,3/4 INCH ID
48978	12-16 V5OLO-S	ELBOW,45°,STRAIGHT THREAD TO ORFS	49834	16 JLO-S	UNION TEE,ORFS
48980	12-16 FLO-S	CONNECTOR,MALE PIPE TO ORFS	49838	12-8 TRLO-BL-S	REDUCER,TUBE END TO SWIVEL,ORFS
48983	16 C5OLO-S	ELBOW,90°,STRAIGHT THREAD TO ORFS	49840	8 JLO-S	UNION TEE,ORFS
48984	16 F5OLO-S	CONNECTOR,STRAIGHT THREAD TO ORFS	49844	10-8 TRLO-BL-S	REDUCER,TUBE END TO SWIVEL,ORFS
48985	16 V5OLO-S	ELBOW,45°,STRAIGHT THREAD TO ORFS	49854	8 P5ON-S	PLUG,STRAIGHT THREAD
48986	16 FLO-S	CONNECTOR,MALE PIPE TO ORFS	49855	1JC43-16-12	HOSE END,FEMALE SWIVEL,SEAL LOK
48988	16 CD45-S	ELBOW,45°,MALE TO FEMALE PIPE	49859	4 P5ON-S	PLUG,STRAIGHT THREAD
48989	12 CD45-S	ELBOW,45°,MALE TO FEMALE PIPE	49861	4 FF5OLO-S	CONNECTOR,LONG,STRAIGHT THREAD TO ORFS
48990	8 CD45-S	ELBOW,45°,MALE TO FEMALE PIPE	49867	12-3/4 F5OG-S	ADAPTER,FEMALE PIPE TO STRAIGHT THREAD
48991	16-12 FLO-S	CONNECTOR,MALE PIPE TO ORFS	51152	6 R6X-S	RUN TEE,SWIVEL NUT,ORFS
48992	16-12 V5OLO-S	ELBOW,45°,STRAIGHT THREAD TO ORFS	51153	6-4 TRTX-S	REDUCER,TUBE END TO SWIVEL,ORFS
48993	XV501-12	BALL VALVE	51154	4-4 GTX	CONNECTOR,FEMALE PIPE TO FLARE TUBE
48994	XV501-16	BALL VALVE	51264	881-12	HOSE,3/4 INCH ID
48995	XV510P-12	BALL VALVE	51265	8 JLO-S	UNION TEE,ORFS
48996	XV510P-16	BALL VALVE	51508	6 BTX-S	NUT,FLARE TUBE
48997	PD341	DIAGNOSTIC NIPPLE, STRAIGHT THREAD	51580	12-8 TRLO-BL-S	TUBE END REDUCER,ORFS
48998	PD 361	DIAGNOSTIC NIPPLE, STRAIGHT THREAD	51628	6 R6X-S	RUN TEE,SWIVEL NUT,ORFS
48999	DT-500-MOMS-5	VALVE,CHECK	51735	3/8 HHP	PLUG,PIPE THREAD
49201	10 V5OLO-S	ELBOW,45°,STRAIGHT THREAD TO ORFS	51803	1J943-6-8	HOSE END,90° FEMALE SWIVEL,SEAL LOK
49202	1JC43-12-10	HOSE END,FEMALE SWIVEL,SEAL LOK	53023	125HBL-5-4	FITTING,HOSE BARB TO MALE PIPE
49203	10-8 V5OLO-S	ELBOW,45°,STRAIGHT THREAD TO ORFS	53497	PKT02585	O-RING KIT
49205	6 F5OHAO-S	UNION,STRAIGHT THREAD	53499	1JC71-16-16	HOSE END,FEMALE SWIVEL,SEAL LOK
49207	PD34BTL	DIAGNOSTIC NIPPLE,SEAL-LOK SWIVEL	53500	3-904	O-RING,STRAIGHT THREAD,-4
49209	8M18F870MX-S	CONNECTOR,METRIC,STRAIGHT THREAD TO FLARE TUBE	53501	3-906	O-RING,STRAIGHT THREAD,-6
49212	8 WGTX-WLN-S	CONNECTOR,BULKHEAD,FEMALE PIPE TO FLARE TUBE	53502	3-908	O-RING,STRAIGHT THREAD,-8
49213	30682-8-8	HOSE END,FEMALE SWIVEL,JIC	53503	3-910	O-RING,STRAIGHT THREAD,-10
49216	831-8	HOSE,1/2 INCH ID			
49217	33982-8-8	HOSE END,90° FEMALE SWIVEL,JIC			
49219	PS-B-35	SLEEVE,NYLON,2.19" ID			
49418	4-6 V5OLO-S	ELBOW,45°,STRAIGHT THREAD TO ORFS			
49511	DT370-MOMS-5	VALVE,CHECK			
49512	1 DD-S	ELBOW,90°,FEMALE PIPE			
49513	1 FF-S	NIPPLE,PIPE			
49514	10 HP5ON-S	PLUG,STRAIGHT THREAD			
49515	12-16 CLO-S	ELBOW,90°,MALE PIPE TO ORFS			
49517	6 HP5ON-S	PLUG,STRAIGHT THREAD			
49519	16-12 F5OLO-S	CONNECTOR,STRAIGHT THREAD TO ORFS			
49520	4 VTX-S	ELBOW,45°,MALE PIPE TO FLARE TUBE			
49530	16 C6LO-S	ELBOW,90°,SWIVEL NUT ORFS			

Fitting Cross References (Continued)

Genie PN	Parker PN	Description	Genie PN	Parker PN	Description
53535	3-912	O-RING, STRAIGHT THREAD, -12	61083	24 F5OLO-S	CONNECTOR, STRAIGHT THREAD TO ORFS
53536	4-PNLO-S	PLUG, TUBE END, ORFS	61086	20 R5OLO-S	RUN TEE, STRAIGHT THREAD
53537	6 PNLO-S	PLUG, TUBE END, ORFS	61090	24-20 F5OLO-S	CONNECTOR, STRAIGHT THREAD TO ORFS
53538	8 PNLO-S	PLUG, TUBE END, ORFS	61091	1J943-24-24	HOSE END, 90° FEMALE SWIVEL, SEAL LOK
53539	10 PNLO-S	PLUG, TUBE END, ORFS	61093	1J978-12-12	HOSE END, 90° FEMALE SWIVEL, JIC
53540	12 PNLO-S	PLUG, TUBE END, ORFS	61095	1JS43-20-16	HOSE END, FEMALE SWIVEL, SEAL LOK
53946	129HB-5-4	FITTING, 90° HOSE BARB TO MALE PIPE	61100	811-24	HOSE, 1 1/2 INCH ID
53951	8-1/4F50G-S	ADAPTER, FEMALE PIPE TO STRAIGHT THREAD	61130	1JS43-24-24	HOSE END, FEMALE SWIVEL, SEAL LOK
53980	6 S6LO-S	BRANCH TEE, SWIVEL NUT TO ORFS	61131	1JS78-12-12	HOSE END, FEMALE SWIVEL, SEAL LOK
54132	4 C6LO-S	ELBOW, 90°, SWIVEL NUT ORFS	61132	1J778-12-12	HOSE END, 45° FEMALE SWIVEL, JIC
54135	11343-16-16	HOSE END, MALE SWIVEL, PIPE	61152	139HB-6-4	ELBOW, 45°, BARB TO MALE PIPE
54283	8-10 C5OLO-S	ELBOW, 90°, STRAIGHT THREAD TO ORFS	61251	BV-0750	BALL VALVE
54428	8M18C870MLO-S	ELBOW, 90° METRIC, STRAIGHT THREAD TO ORFS	61259	4 CC5OLO-S	ELBOW, 90° LONG, STRAIGHT THREAD TO ORFS
54803	FS-F-16-10	SLEEVE, FIRE, .96" ID	61260	20-12 TRLO-BL	REDUCER, TUBE END TO SWIVEL, ORFS
54954	10143-2-4	HOSE END, MALE PIPE	61262	12 C6LO-S	ELBOW, 90°, SWIVEL NUT ORFS
55190	3/8 HP-S	PLUG, PIPE THREAD	61263	20 F5OHAO-S	UNION, STRAIGHT THREAD
55448	8 HLO-S	UNION, ORFS	61264	6-10 C5OLO-S	ELBOW, 90°, STRAIGHT THREAD TO ORFS
55839	6 F65OX-S	CONNECTOR, STRAIGHT THREAD TO 37° SWIVEL	61265	6 WNLO-WLNL-S	UNION, BULKHEAD 45°, ORFS
55968	10 C5OX-S	ELBOW, 90°, STRAIGHT THREAD TO FLARE TUBE	61268	4 WNLO-WLNL-S	UNION, BULKHEAD 45°, ORFS
56003	6 CC5OLO-S	ELBOW, 90° LONG, STRAIGHT THREAD TO ORFS	61269	4 WLO-WLNL-S	UNION, BULKHEAD, ORFS
56166	BV-0837	BALL VALVE, 90°	61272	12 AOEL6	ELBOW, 90°, STRAIGHT THREAD TO ORFS SWIVEL
56188	10143-8-6	HOSE END, MALE PIPE	61316	482TC-16	HOSE, 1 INCH ID
56233	2-011	O-RING, ORFS, -4	61321	6 JLO-S	UNION TEE, ORFS
56234	2-012	O-RING, ORFS, -6	61327	782-12	HOSE, 3/4 INCH ID
56235	2-014	O-RING, ORFS, -8	61328	881-24	HOSE, 1 1/2 INCH ID
56236	2-016	O-RING, ORFS, -10	61336	11943-20-24	HOSE END, 90° FLANGE HEAD
56237	2-018	O-RING, ORFS, -12	61345	12 WJLO-WLNL-S	RUN TEE, BULKHEAD, ORFS
56238	2-021	O-RING, ORFS, -16	61346	8 WNLO-WLNL-S 4	UNION, BULKHEAD 45°, ORFS
56352	6 WLNL-S	LOCKNUT, BULKHEAD	61569	33782-8-8	HOSE END, 45° FEMALE SWIVEL, JIC
56353	3J782-12-12	HOSE END, 45° FEMALE SWIVEL, SEAL LOK	61610	12 FF5OLO-S	CONNECTOR, LONG, STRAIGHT THREAD TO ORFS
56354	3J982-12-12	HOSE END, 90° FEMALE SWIVEL, SEAL LOK	61742	1/8 X 1.5 FFF	NIPPLE, PIPE
56604	10-8 F5OLO-S	CONNECTOR, STRAIGHT THREAD TO ORFS	63426	8 PNTX-S	PLUG, FLARE TUBE
56639	3JC82-10-10	HOSE END, FEMALE SWIVEL, SEAL LOK			
56640	3J982-10-10	HOSE END, 90° FEMALE SWIVEL, SEAL LOK			
56655	3JC82-8-10	HOSE END, FEMALE SWIVEL, SEAL LOK			
56676	10-8 C5OLO-S	ELBOW, 90°, STRAIGHT THREAD TO ORFS			
56776	471TC-6	HOSE, 3/8 INCH ID			
56777	471TC-8	HOSE, 1/2 INCH ID			
56789	811-16	HOSE, 1 INCH ID			
57884	3/8 FF	NIPPLE, PIPE			
59335	6 FNL-S	CAP, TUBE END			
59342	4 FNL-S	CAP, TUBE END			
59371	8 HP5ON-S	PLUG, STRAIGHT THREAD			
60653	BV-0751	BALL VALVE			
60806	125HB-3-4	FITTING, HOSE BARB TO MALE PIPE			
61064	5-1/4 F50G-S	ADAPTER, FEMALE PIPE TO STRAIGHT THREAD			
61079	4 WELO-WLNL-S	UNION, 90° BULKHEAD W/NUT, ORFS			
61080	6 WLO-WLNL-S	UNION, BULKHEAD, ORFS			

Fitting Cross References (Continued)

Genie PN	Parker PN	Description	Genie PN	Parker PN	Description
64271	4 WLO-WLNL-S	UNION,BULKHEAD,ORFS	75631	801-6	HOSE,3/8 INCH ID
64272	6 WLO-WLNL-S	UNION,BULKHEAD,ORFS	75654	20 F5OLO-S	CONNECTOR,STRAIGHT THREAD TO ORFS
65776	8 F65OL-S	CONNECTOR,STRAIGHT THREAD TO ORFS SWIVEL	75655	1J943-20-20	HOSE END,90° FEMALE SWIVEL,SEAL LOK
65880	6001012	O-RING KIT	75656	881-20	HOSE,1-1/4 INCH ID
66154	6 WTX-WLNS	UNION,BULKHEAD,FLARE TUBE	75971	8 F5OHAO-S	UNION,STRAIGHT THREAD
66155	6 WETX-S	UNION,BULKHEAD 90°,FLARE TUBE	77307	1JB43-8-8	HOSE END,BULKHEAD,SEAL LOK
66156	6 WLN-S	BULKHEAD LOCKNUT	77309	8 WLNL-S	BULKHEAD LOCKNUT
66389	6-8 F5OX-S	CONNECTOR,STRAIGHT THREAD TO FLARE TUBE	77379	8M18C87OMX-S	ELBOW,90° METRIC,STRAIGHT THREAD TO FLARE TUBE
66392	6 R5OX-S	RUN TEE,STRAIGHT THREAD	77703	3J982-8-8	HOSE END,90° FEMALE SWIVEL,SEAL LOK
66396	811-12	HOSE,3/4 INCH ID	77711	801-10	HOSE,5/8 INCH ID
66829	H3174PP	CLAMP,TUBE	77758	12 WNLO-WLNL-S	UNION,BULKHEAD 45°,ORFS
67217	4 KLO-S	UNION,CROSS,ORFS	78091	6 C6X-S	ELBOW,90°,SWIVEL NUT TO FLARE TUBE
67339	10-6 F5OX-S	CONNECTOR,STRAIGHT THREAD TO FLARE TUBE	78684	30582-8-8B	HOSE END,PUSH LOK,MALE
67357	13943-8-6	HOSE END,90° FEMALE SWIVEL,JIC	78852	549-2	HOSE,1/8 INCH ID
67358	10 HP5ON-S	PLUG,STRAIGHT THREAD	78855	10657-4-2	HOSE END,FEMALE SWIVEL,JIC
67371	12 S6LO-S	BRANCH TEE,SWIVEL NUT TO ORFS	79138	PS-B-37	SLEEVE,NYLON,2.38" ID
67498	4 FNL-S	CAP, TUBE END	79476	1JS43-6-8	HOSE END,FEMALE SWIVEL,SEAL LOK
67906	DC-370-F0F0-5	VALVE,CHECK	79847	12-3/4 A0EG-S	ELBOW,90°,STRAIGHT THREAD TO FEMALE PIPE
69316	8 FLO-S	CONNECTOR,MALE PIPE TO ORFS	80044	8 CLO-S	ELBOW,90°,MALE PIPE TO ORFS
69333	H3174PP	CLAMP,HYDRAULIC HOSE	80502	8 F5OX-S	CONNECTOR,STRAIGHT THREAD TO FLARE TUBE
69503	4 F65OX-S	CONNECTOR,STRAIGHT THREAD TO 37° SWIVEL	80503	8 C5OX-S	ELBOW,90°,STRAIGHT THREAD TO FLARE TUBE
69775	8 FNL-S	CAP, TUBE END	81010	AS-B-27	SLEEVE,NYLON,1.63" ID
71038	1/4X1/4F3HG-S	ADAPTER,CONVERSION	83052	821-6	HOSE,3/8 INCH ID
71196	12-8 F5OLO-S	CONNECTOR,STRAIGHT THREAD TO ORFS	83053	821-8	HOSE,1/2 INCH ID
71383	1/4 CD45-S	ELBOW,45°,MALE TO FEMALE PIPE	83054	821-12	HOSE,3/4 INCH ID
72270	12FNL-S	CAP, TUBE END	83055	30682-6-6	HOSE END,FEMALE SWIVEL,JIC
73436	60C-4	SLEEVE,COMPRESSION	83056	30682-12-12	HOSE END,FEMALE SWIVEL,JIC
73437	61C-4	NUT,COMPRESSION	83057	33782-6-6	HOSE END,45° FEMALE SWIVEL,JIC
73438	33482-4-4B	HOSE END,PUSH LOK,MALE	83058	33982-6-6	HOSE END,90° FEMALE SWIVEL,JIC
73767	1CD-S	ELBOW,90°,MALE TO FEMALE PIPE	83060	33982-12-12	HOSE END,90° FEMALE SWIVEL,JIC
73768	20-16-F5OG5-S	ADAPTER,FEMALE PIPE TO STRAIGHT THREAD	83063	13743-4-4	HOSE END,45° FEMALE SWIVEL,JIC
73769	16-20 F5OLO-S	CONNECTOR,STRAIGHT THREAD TO ORFS			
74660	6-8 F42EDMLO-S	CONNECTOR,MALE BSPP TO ORFS			
74661	8-8 F42EDMLO-S	CONNECTOR,MALE BSPP TO ORFS			
75007	4 FLO-S	CONNECTOR,MALE PIPE TO ORFS			
75008	1/8 HP-S	PLUG,PIPE THREAD			
75014	1/2 HP-S	PLUG,PIPE THREAD			
75042	8 WELO-WLNL-S	UNION,90° BULKHEAD W/NUT,ORFS			
75043	3/4 FF-S	NIPPLE,PIPE			
75254	24 F5OHAO-S	UNION,STRAIGHT THREAD			
75255	12 F5OHAO-S	UNION,STRAIGHT THREAD			
75256	XV506P-24	BALL VALVE			
75574	4 WLNL-S	BULKHEAD LOCKNUT			
75612	8 WJLO-WLNL-S	RUN TEE, BULKHEAD,ORFS			
75613	12-8 F5OG5-S	ADAPTER,FEMALE PIPE TO STRAIGHT THREAD			
75614	8 CC5OLO-S	ELBOW,90° LONG,STRAIGHT THREAD TO ORFS			
75628	1JB43-4-4	HOSE END,BULKHEAD,SEAL LOK			

Fitting Cross References (Continued)

Genie PN	Parker PN	Description	Genie PN	Parker PN	Description
83064	13743-8-8	HOSE END,45° FEMALE SWIVEL,JIC	89449	6 WJLO-WLNL-S	RUN TEE, BULKHEAD,ORFS
83065	13743-12-12	HOSE END,45° FEMALE SWIVEL,JIC	89489	4 WJMLO-S	BRANCH TEE,BULKHEAD,ORFS
83066	13943-8-8	HOSE END,90° FEMALE SWIVEL,JIC	89551	1JB43-6-6	HOSE END,BULKHEAD,SEAL LOK
83067	14143-6-6	HOSE END,90° FEMALE SWIVEL,JIC	89552	1JB43-8-8	HOSE END,BULKHEAD,SEAL LOK
83068	14143-8-8	HOSE END,90° FEMALE SWIVEL,JIC	89593	20 C5OLO-S	ELBOW,90°,STRAIGHT THREAD TO ORFS
83069	14143-12-12	HOSE END,90° FEMALE SWIVEL,JIC	94161	8-8 CLO-S	ELBOW,90°,MALE PIPE TO ORFS
83070	772-8	HOSE,1/2 INCH ID	94358	351TC-12	HOSE,3/4 INCH ID
83071	10671-8-8	HOSE END,FEMALE SWIVEL,JIC	94418	20 FLO-S	CONNECTOR,MALE PIPE TO ORFS
83072	10671-12-12	HOSE END,FEMALE SWIVEL,JIC	96358	12 TX-S	SLEEVE,FLARE TUBE
83073	13771-8-8	HOSE END,45° FEMALE SWIVEL,JIC	96359	12 BTX-S	NUT,FLARE TUBE
83074	13771-12-12	HOSE END,45° FEMALE SWIVEL,JIC	96397	8 F5OX-S	CONNECTOR,STRAIGHT THREAD TO FLARE TUBE
83075	13971-8-8	HOSE END,90° FEMALE SWIVEL,JIC	96398	12-8 F5OX-S	CONNECTOR,STRAIGHT THREAD TO FLARE TUBE
83076	13971-12-12	HOSE END,90° FEMALE SWIVEL,JIC	96402	10343-6-6	HOSE END,MALE,JIC
83077	14171-8-8	HOSE END,90° FEMALE SWIVEL,JIC	96407	30382-6-6B	HOSE END,MALE,JIC
83078	14171-12-12	HOSE END,90° FEMALE SWIVEL,JIC			
83080	13943-16-16	HOSE END,90° FEMALE SWIVEL,JIC			
83103	10671-16-12	HOSE END,FEMALE SWIVEL,JIC			
83104	10671-10-12	HOSE END,FEMALE SWIVEL,JIC			
83112	1JC71-8-8	HOSE END,FEMALE SWIVEL,SEAL LOK			
83113	1JS71-16-12	HOSE END,FEMALE SWIVEL,SEAL LOK			
83114	1JS71-10-12	HOSE END,FEMALE SWIVEL,SEAL LOK			
83115	1J971-8-8	HOSE END,90° FEMALE SWIVEL,SEAL LOK			
83116	1J171-8-8	HOSE END,90° FEMALE SWIVEL,SEAL LOK			
83117	1J771-8-8	HOSE END,45° FEMALE SWIVEL,SEAL LOK			
83127	1J543-6-8	HOSE END,90° FEMALE SWIVEL,JIC			
83128	1JC43-6-8	HOSE END,FEMALE SWIVEL,SEAL LOK			
87033	12-6 TRLO-S	REDUCER,TUBE END TO SWIVEL,ORFS			
87034	3J782-8-8	HOSE END,45° FEMALE SWIVEL,SEAL LOK			
87172	12 HP5ON-S	PLUG,STRAIGHT THREAD			
87185	8 WNLO-WLNL-S	UNION,BULKHEAD 45°,ORFS			
87246	4 C6X-S	ELBOW,90°,SWIVEL NUT TO FLARE TUBE			
87679	6 LHP-S	FLANGE SEAL FITTING, MALE			
87681	6PLS N0702	BONDED SEAL			
88100	SR88100	ADAPTER,OIL DRAIN,GM 3.0L			
88311	1JS43-20-20	HOSE END,FEMALE SWIVEL,SEAL LOK			
88353	20 V5OLO-S	ELBOW,45°,STRAIGHT THREAD TO ORFS			
88474	10081-20	Crimp Shell, 1.25"			
88475	1988-20-24	HOSE END,90° FLANGE HEAD			
88476	JS88-24-24	HOSE END,FEMALE SWIVEL,SEAL LOK			
88477	1JC88-20-20	HOSE END,FEMALE SWIVEL,SEAL LOK			
88478	811-20	HOSE,11/4 INCH ID			
88936	20-16 F5OLO-S	CONNECTOR,STRAIGHT THREAD TO ORFS			
88937	20-16 FLO-S	CONNECTOR,MALE PIPE TO ORFS			
88938	1JC88-16-16	HOSE END,FEMALE SWIVEL,SEAL LOK			
88939	1J988-16-16	HOSE END,90° FEMALE SWIVEL,ORFS			
88940	811-16	HOSE,1 INCH ID			
88944	1J988-20-20	HOSE END,90° FEMALE SWIVEL,ORFS			
89403	16 VLO-S	ELBOW,45°,MALE PIPE TO ORFS			

California Proposition 65



WARNING

Operating, servicing and maintaining this equipment can expose you to chemicals including engine exhaust, carbon monoxide, phthalates, and lead, which are known to the State of California to cause cancer and birth defects or other reproductive harm. These chemicals can be emitted from or contained in other various parts and systems, fluids and some component wear by-products. To minimize exposure, avoid breathing exhaust, do not idle the engine except as necessary, service your equipment and vehicle in a well-ventilated area and wear gloves or wash your hands frequently when servicing your equipment or vehicle and after operation. For more information go to www.P65Warnings.ca.gov/passenger-vehicle.

Breathing diesel engine exhaust exposes you to chemicals known to the State of California to cause cancer and birth defects or other reproductive harm.

- Always start and operate the engine in a well-ventilated area.
- If in an enclosed area, vent the exhaust to the outside.
- Do not modify or tamper with the exhaust system.
- Do not idle the engine except as necessary.

For more information go to www.P65warnings.ca.gov/diesel.

Parts Manual

Z-45/25, Z-45/25J

DC

from SN Z4525D-940

Part No.
1283270GT

Rev A2

Genie
A TEREX BRAND