

Replacement kit CD2

Fits: All current CD2-systems. Make sure to use the correct kit below depending on number of functions 6 or 8 and geographical location, Europe or US/Nafta

Background:

If the radio decoder is broken in a CD2 system a replacement kit must be purchased as the old radio module is obsolete from manufacturer and no longer available.

Recommended tools for the operation:

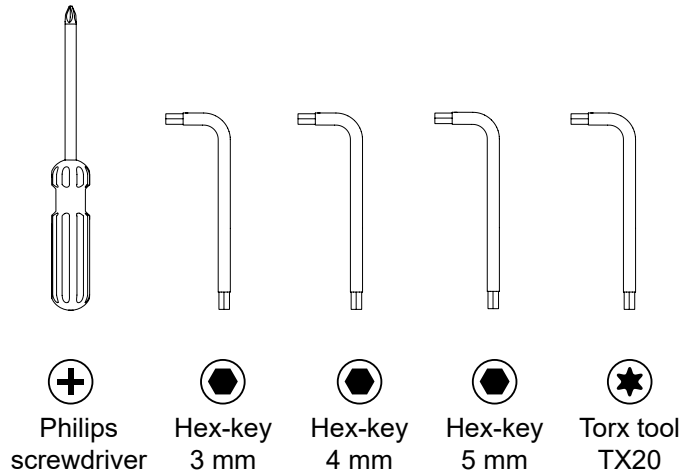

Replacement kits:

There are four different kits available - each including a top box controller 6F or 8F excl. levers + a radio decoder.
 E=Region Europe (868 MHz) and U=Region US/Nafta (915 Mhz).

Radio replacement kit 6F CD2 E - ISM 868 MHz
 Hiab part no. 462 4814

Radio replacement kit 8F CD2 E - ISM 868 MHz
 Hiab part no. 462 4815

Radio replacement kit 6F CD2 U - ISM 915 MHz
 Hiab part no. 462 4816

Yellow mark on antenna

Radio replacement kit 8F CD2 U - ISM 915 MHz
 Hiab part no. 462 4817

Yellow mark on antenna

Installation, step 1

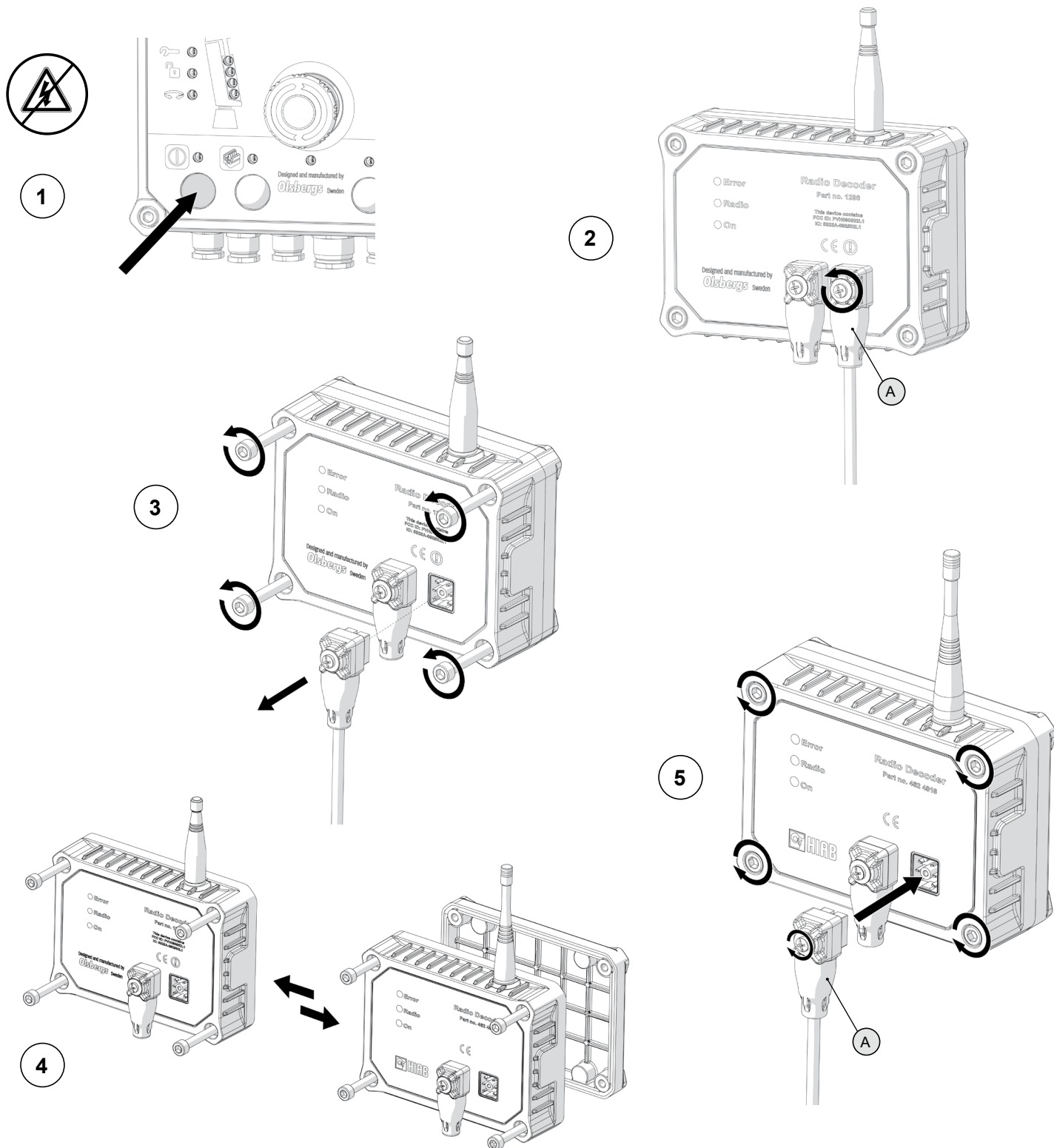
Concerns: Radio decoder

Replace the radio decoder

1. Switch of the power on the power box.
2. Unscrew and remove the right-hand cable connector (A) on the radio decoder using a philips screwdriver (cable between radio decoder and power box).
3. Loosen four screws, one in each corner using a 5 mm hex-key and remove the radio decoder.
4. Put the new radio decoder in place.
5. Tighten the four screws in the corner and gently fasten the cable connector (A) in the right-hand connector on the radio decoder.

Concerns: Controller

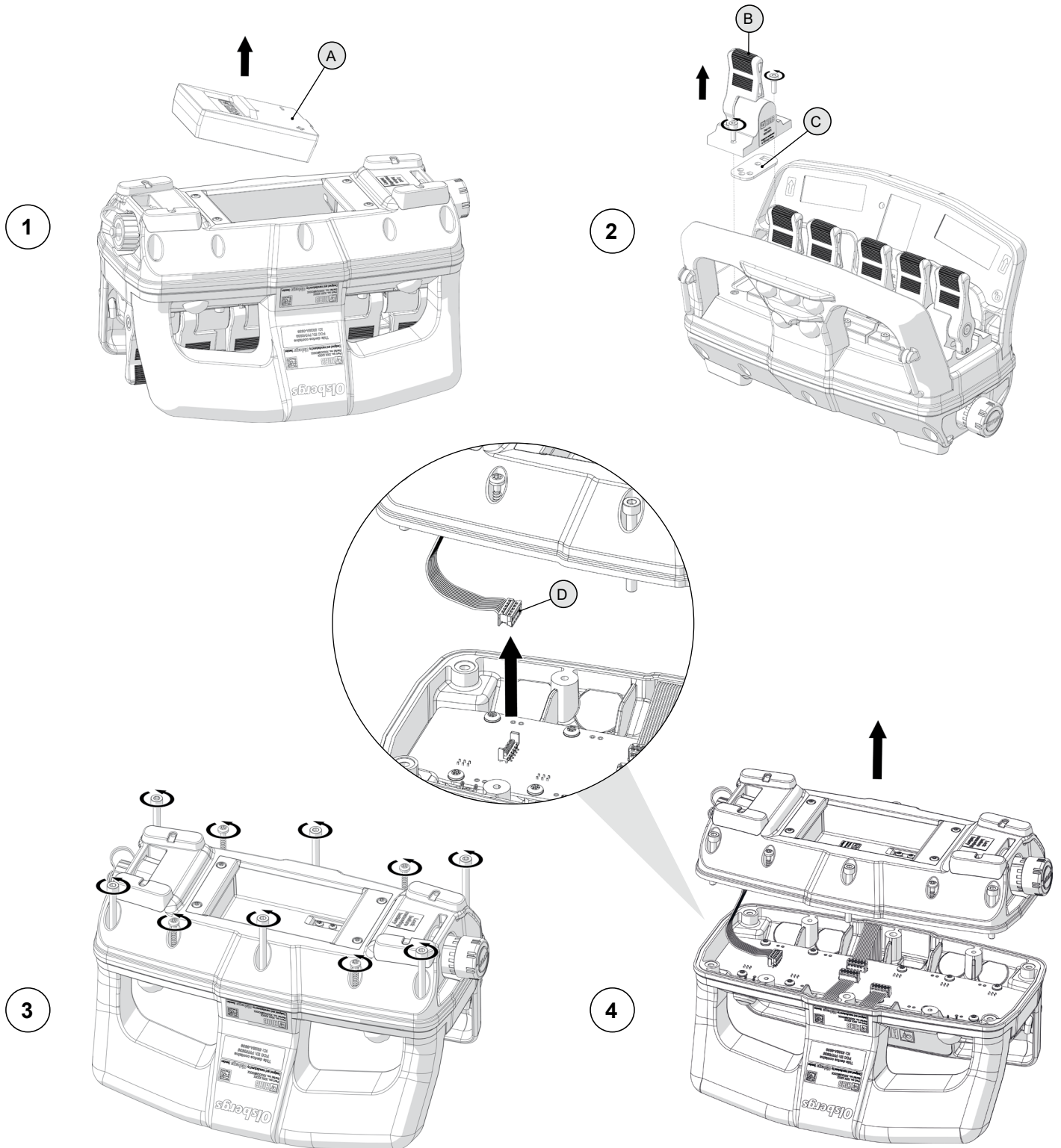
**Replace the “top-box” on the controller**

1. Remove the battery (A) from the controller.
2. Unscrew and remove the levers (B) and rubber packing (C) from the top box of the controller using a 3 mm hex-key.
3. Turn the controller up-side-down and loosen 6 pcs black screws (4 mm hex-key) and 4 pcs screws (TX20) which hold the bottom part of the controller in place.
4. Gently lift the bottom part with the screws still in the holes, then gently remove the ribbon cable (D) between the bottom and top and remove the bottom part.

Installation, step 2

Concerns: Controller

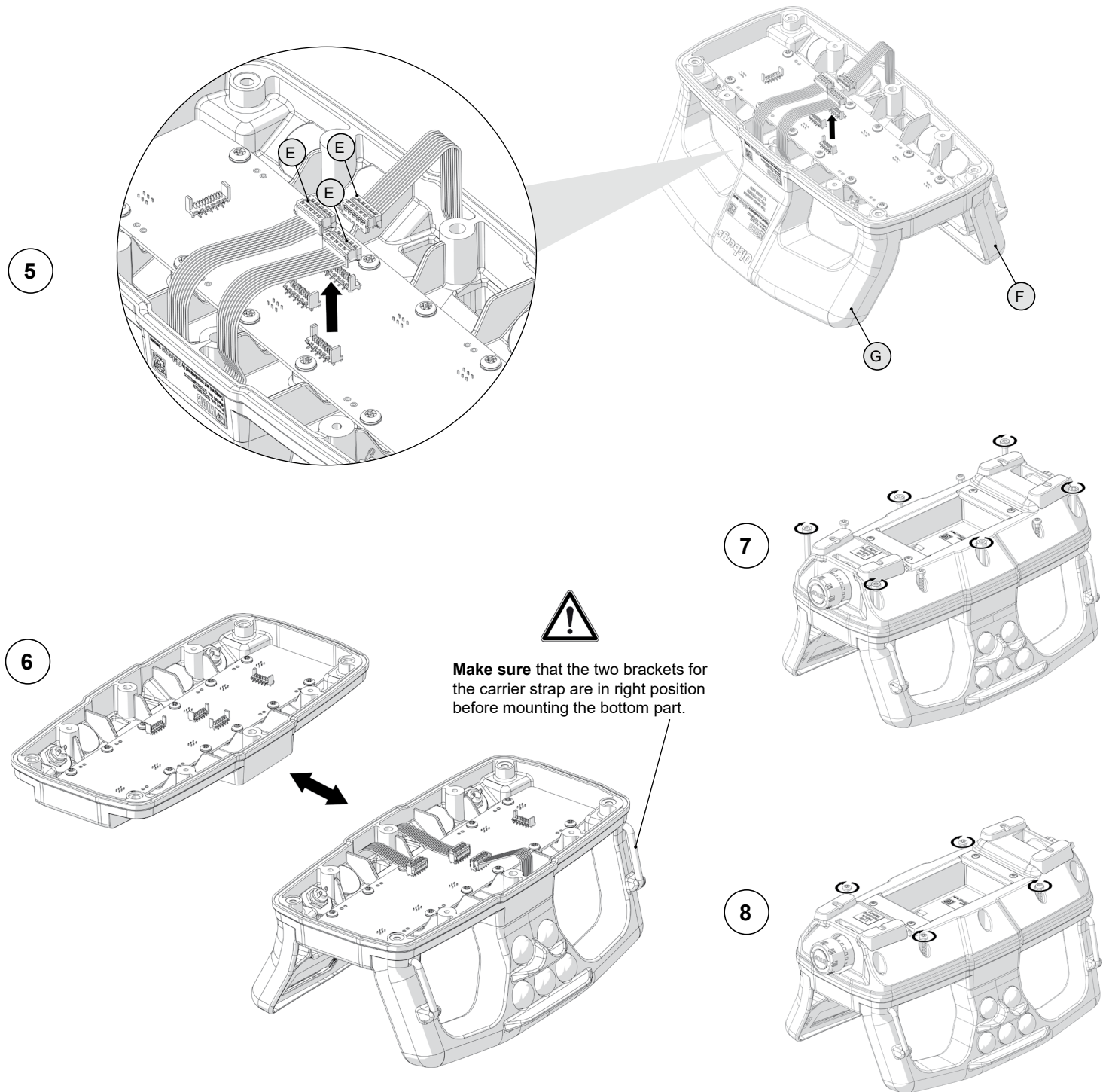

Replace the “top-box” on the controller

5. Gently remove the ribbon cables (E) of the push-button handle (F) and display handle (G)
6. Change the existing top box of the controller to the new one and gently re-connect the ribbon cables (E) of the push-button handle and display handle to the new top box.
7. Put back bottom part and tighten the black screws first (max 2.0 Nm) – starting with the corners screw of the push-button handle and then the display handle screw opposite.
8. Then tighten the TX20 screws (max 1.0 Nm).

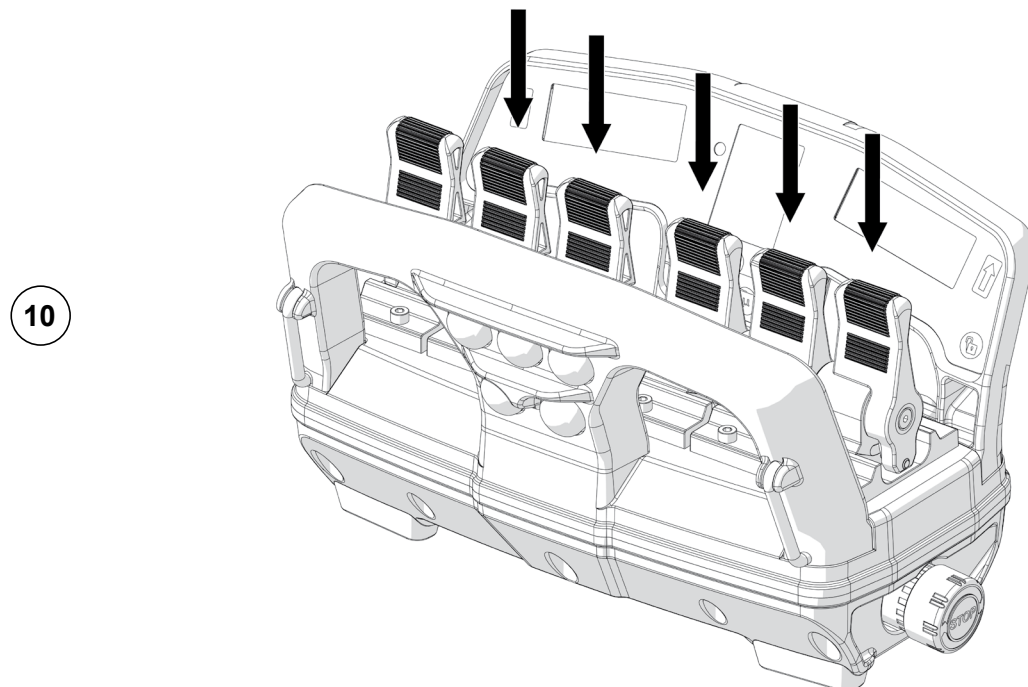
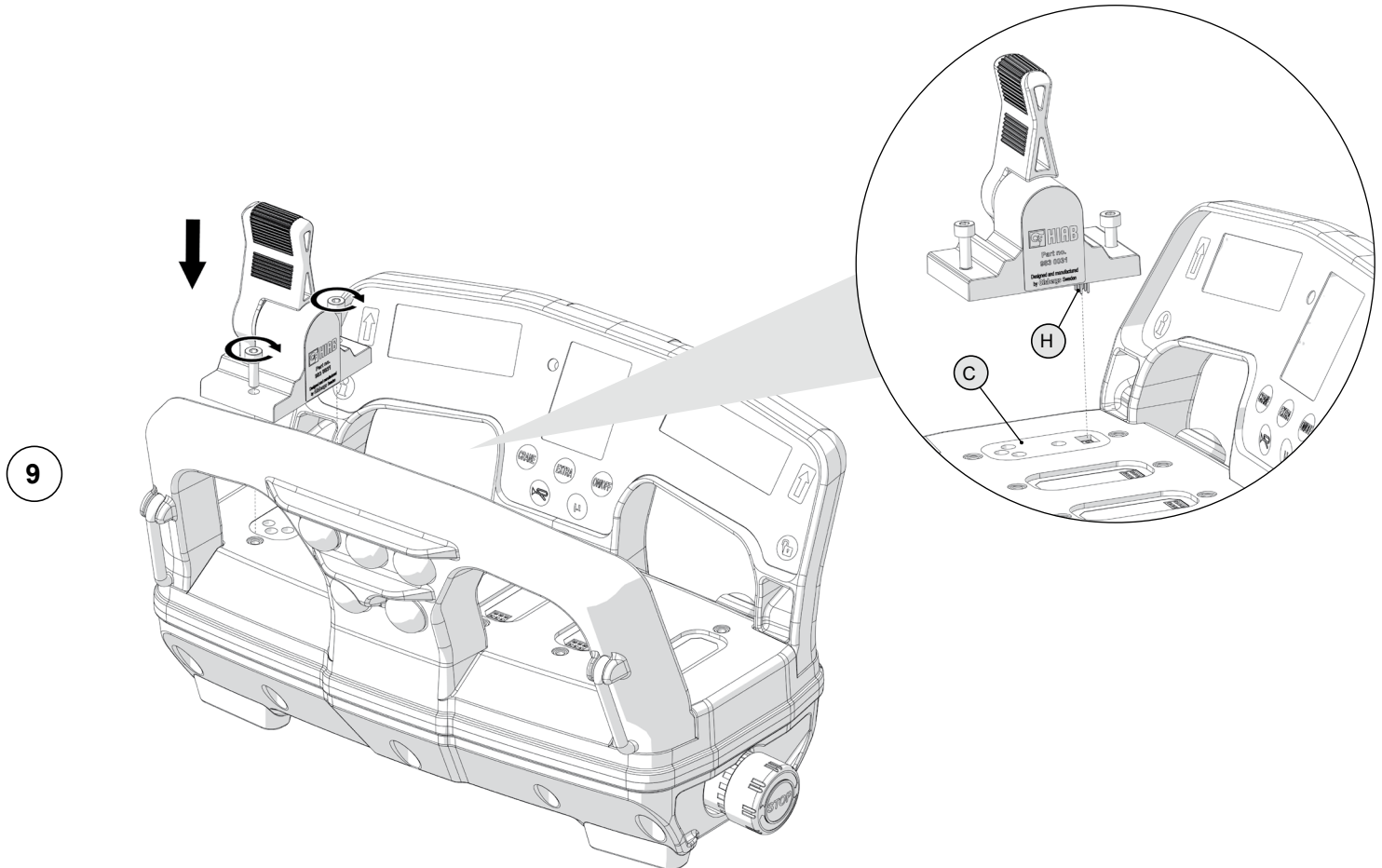
Concerns: Controller**Replace the “top-box” on the controller**

9. When all 10 screws are in place it is time to put back the levers. Start with the red lever - the red lever should be on the left facing the displays. Put back the rubber gasket (C) and gently place the lever pin contact (H) in the contact - no force is needed. Make sure that the lever is in straight position before tightening the screws.
10. Repeat the last step with the rest of the black levers.

Pairing

Concerns: Radio decoder and controller

The radio in the radio decoder and the radio in the top box controller are paired from factory and should normally start without any problem. If for some reason the radio link fails – make a new pairing of the hand control and radio decoder.

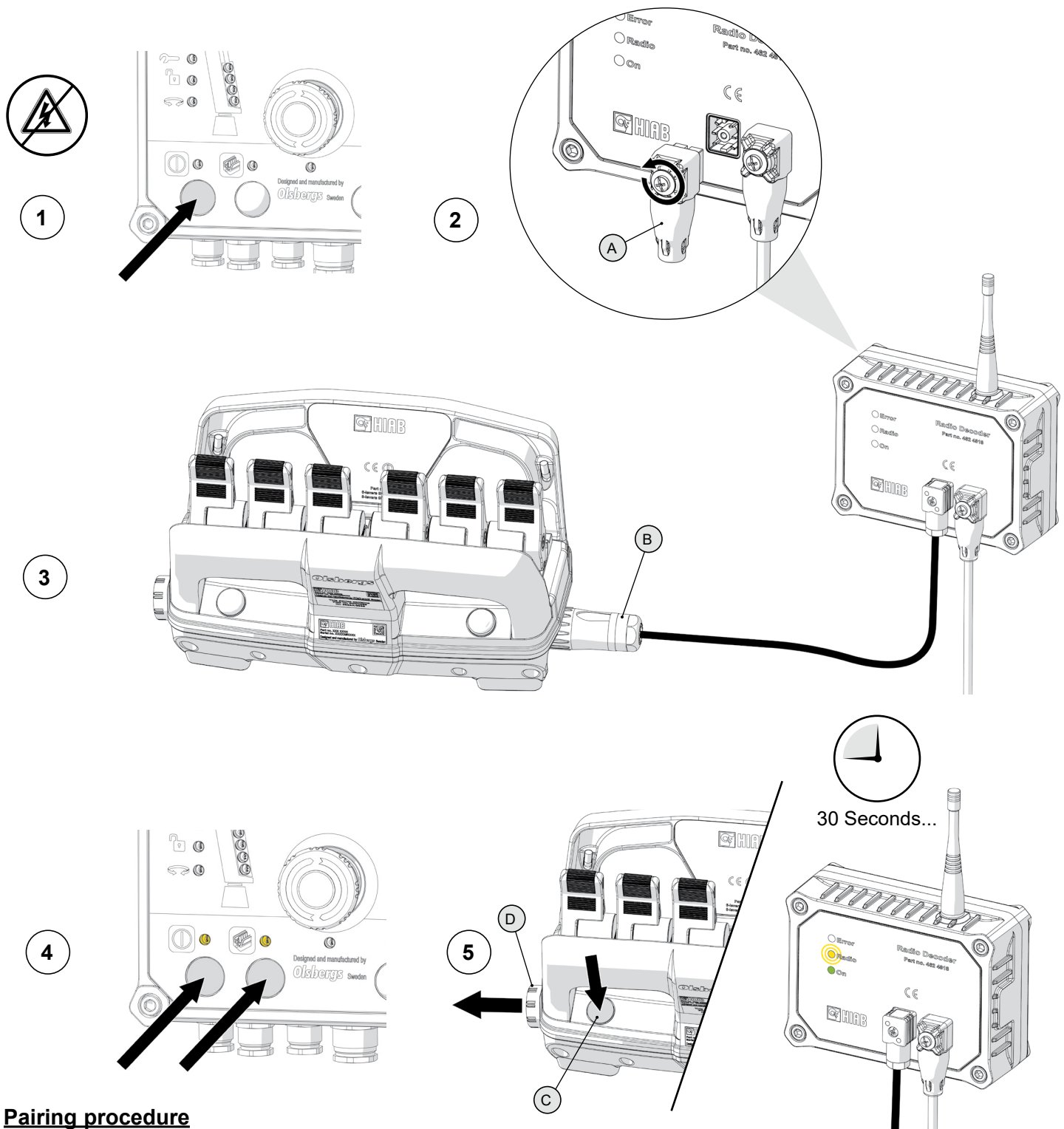

Pairing procedure

1. Switch off the Power Box.
2. Unscrew the left-hand connector (A) on the radio decoder and remove it.
3. Connect the hand controller with the accompanying cable (E0781) (B) to the radio decoder.
4. Switch on the Power box and select "remote".
5. Hold down the release button (C) on the hand controller while pulling out the stop button (D). When the yellow LED on the decoder starts to blink, let go of the release button. When the procedure is complete, the yellow LED goes out. If the procedure was successful, only the green LED remains lit, if not, the red LED is lit. The procedure can take up to half a minute.

EU Declaration of Conformity

Olsbergs Electronics AB

Fågelsångsvägen 10, SE-186 42 Vallentuna, Sweden

declare under our sole responsibility that the product(s):

Product Name: CombiDrive 2

Model Number(s): Top controller box 6F 868, Top controller box 8F 868, Radio Decoder CD2 868

Part Number(s): E2200 (462 4820), E2211 (462 4821), 1384 (462 4818)

to which this declaration relates is(are) in conformity with the essential requirements and other relevant requirements of EU Directive 2014/53/EU (RED) Radio Equipment Directive.

Type	Essential Requirements
Health & Safety (article 3.1a)	EN 62368-1:2014 EN 62311:2008
EMC (article 3.1b)	EN 301 489-1 V2.1.1 (2017-02) in accordance with the specific requirements of EN 301 489-3 V2.1.1 (2017-03)
Spectrum (article 3.2)	EN 300 220-2 V3.1.1 (2017-02)

Vallentuna, Sweden, March 2022

Jan-Erik Steen

Managing Director, Olsbergs Electronics AB