



Chelsea[®] Power Take-Off

890 Series Service Manual

aerospace
climate control
electromechanical
filtration
fluid & gas handling
hydraulics
pneumatics
process control
sealing & shielding

CHELSEA®

WARNING

FAILURE OR IMPROPER SELECTION OR IMPROPER USE OF THE PRODUCTS AND/OR SYSTEMS DESCRIBED HEREIN OR RELATED ITEMS CAN CAUSE DEATH, PERSONAL INJURY AND PROPERTY DAMAGE.

This document and other information from Parker Hannifin Corporation, its subsidiaries and authorized distributors provide product and/or system options for further investigation by users having technical expertise. It is important that you analyze all aspects of your application and review the information concerning the product or system in the current product catalog. Due to the variety of operating conditions and applications for these products or systems, the user, through its own analysis and testing, is solely responsible for making the final selection of the products and systems and assuring that all performance, safety and warning requirements of the application are met.

The products described herein, including without limitation, product features, specifications, designs, availability and pricing, are subject to change by Parker Hannifin Corporation and its subsidiaries at any time without notice.

Offer of Sale

The items described in this document are hereby offered for sale by Parker Hannifin Corporation, its subsidiaries or its authorized distributors. This offer and its acceptance are governed by the provisions stated in the "Offer of Sale".

Contents

Section 1	1-10
Disassembly/Assembly Instructions	2
Model Number Designation.....	3
Assembly Arrangements	4
Exploded View – 890HEFJW-B5AF	5
Bill of Materials – 890HEFJW-B5AF	6
Exploded View – 890HBFJW-B5XS	7
Bill of Materials – 890HBFJW-B5XS	8
Exploded View – 890ECFJW-B5AF	9
Bill of Materials – 890ECFJW-B5AF	10
Section 2	11-19
Disassembly.....	12-15
Assembly.....	16-19
Section 3	20-24
Electrical Installation Sketch without E.O.C. for 890/892 Series (SK-459 Rev C) ...	21
Hose Installation Sketch for 890/892 Series (SK-504)	22
Torque Chart	23
Gear Chart	24
Section 4	25-28
Mounting the P.T.O. on the Transmission.....	26-28
Section 5	29-32
Troubleshooting.....	30-32
Offer of Sale	36

**S
E
C
T
I
O
N

1**

NOTES

1	Visually inspect parts before assembly for flaws.
2	The item numbers identifying parts are the same item numbers used on the engineering drawings.
3	Ensure tools and fixtures are current and have the required inspection and calibration labels and/or tags.
4	The terms OUTPUT and DRIVE are used interchangeably.
5	Lubricate most bearings before assembly. Use MELCOMOL "Y", EP-2 or equal.
6	When assembling bearings, always place the bearings rounded end into the part.
7	Use Parker O-Lube or equal to lubricate O-Rings and seals before assembly.
8	When assembling O-Rings, do not roll it into their grooves. Use a O-Ring tool for assembly. O-Rings are not to be twisted or damaged.
9	Always reference the current Chelsea Parts List for part numbers and assemblies. 890 Series is HY25-2890-M1/US

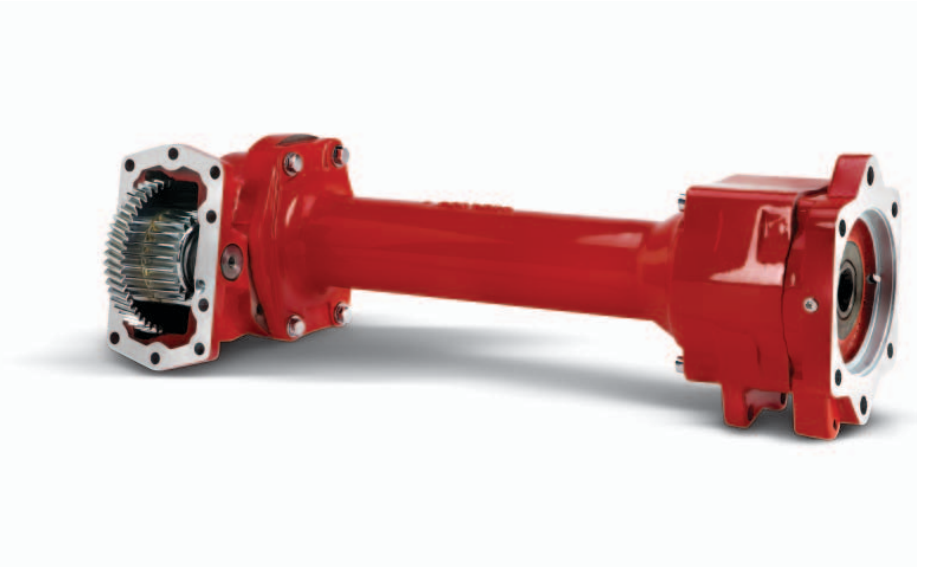
**Suggested Tools**

Safety Glasses	Shop Press	Pliers	Gasket Scraper Tool
3/4" Socket	5/32" Hex Bit Driver	Hammer/Mallet	

Suggested Service Kits

Part Number	Description
328948-36X	Kit Gasket & Installation
7170-86X	Kit Mounting
329644-1X	Kit Mounting & Installation ("XS")
329644-2X	Kit Mounting & Installation ("AF")

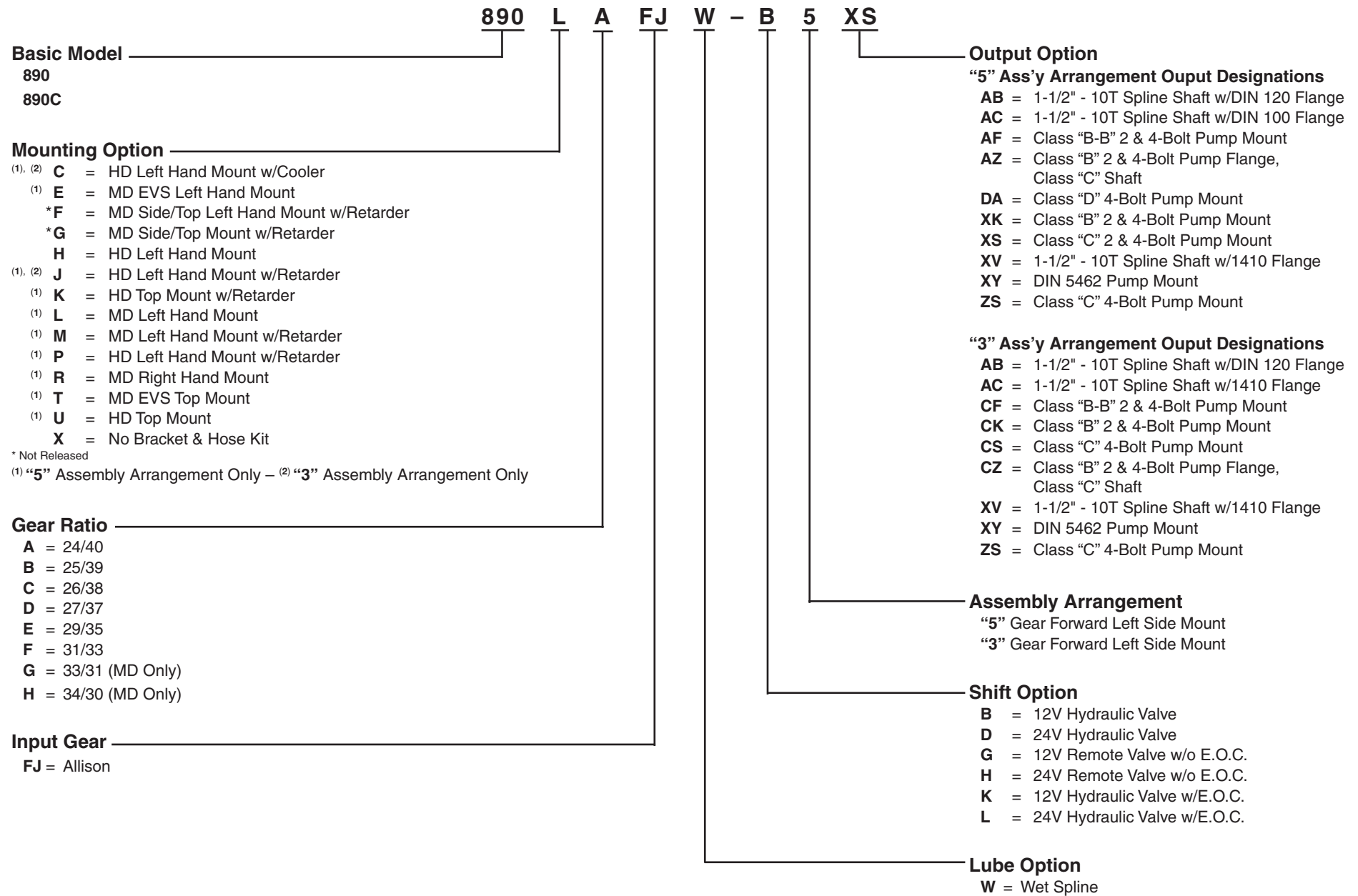

“AF” Output – Assembly 5

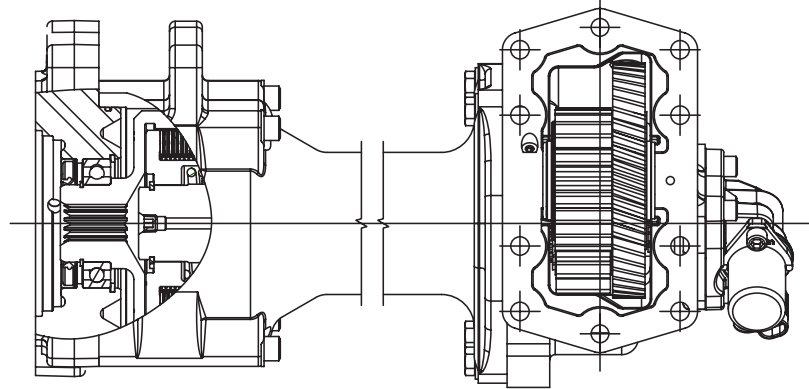
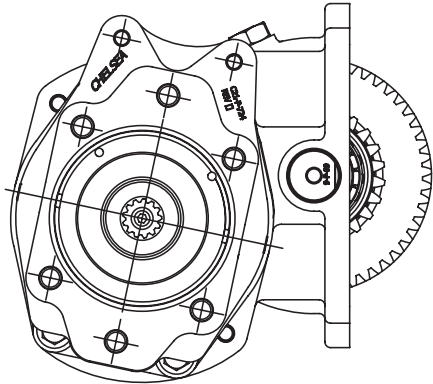

“XS” Output – Assembly 5

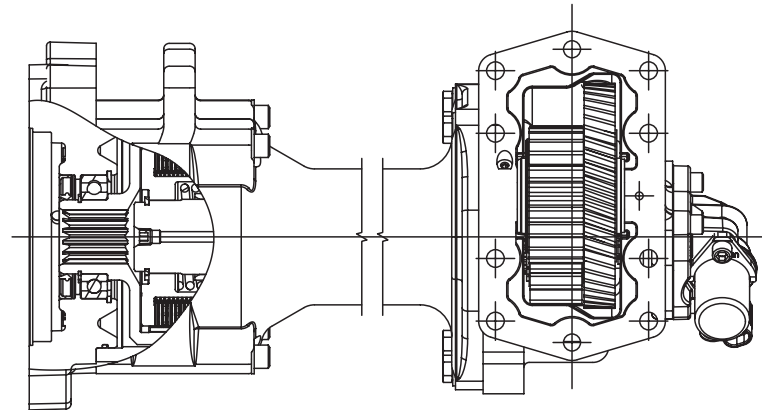
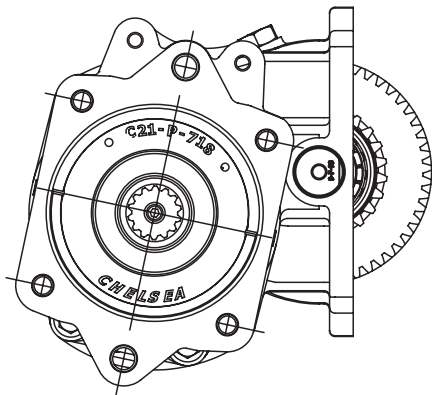

Exploded View – 890HEFJW-B5AF

**Service Manual
890 Series**

890HAFJW-B5AF
890HBFJW-B5AF
890HCFJW-B5AF
890HDFJW-B5AF
890HFFJW-B5AF
890HGFJW-B5AF
890HHFJW-B5AF

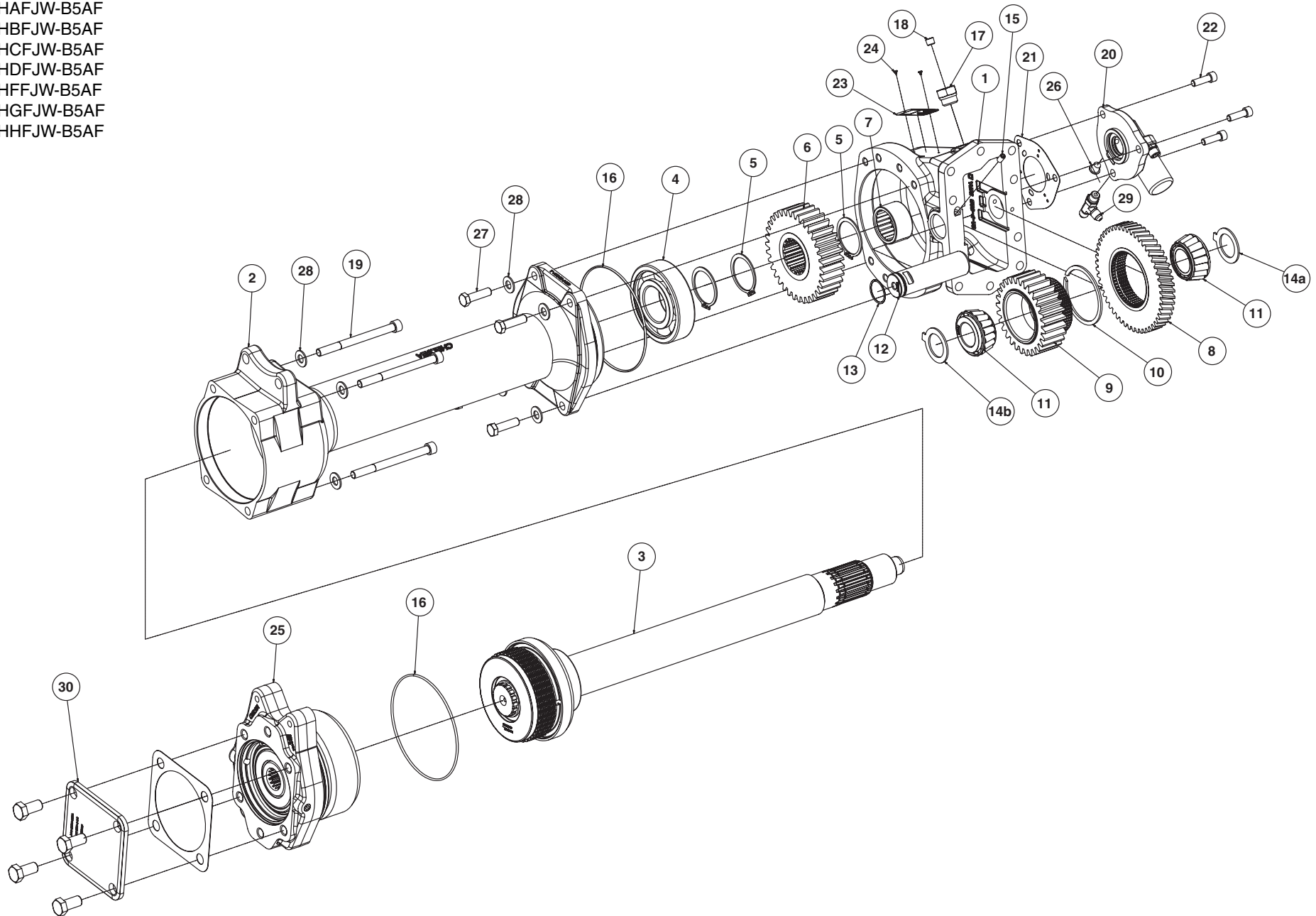

Bill of Materials

**Service Manual
890 Series**

890HEFJW-B5AF

Item	Part Number	Description	Qty.	Item	Part Number	Description	Qty.
1	1-P-629	Housing.....	1	15	378452-7	Set Screw SH .250" - 20 x .500".....	1
2	54-P-22	Bearing Retainer.....	1	16	28-P-245	O-Ring 5.017" x .103".....	2
3	329607X	Drive Shaft & Clutch Assembly.....	1	17	379242	Adapter Straight .125" - 27 x .750" - 16.....	1
4	550026	Ball Bearing 1.7717" x 3.937 x .9843".....	1	18	379231	Pipe Plug .125" - 27.....	1
5	379668	Lockring.....	3	19	379433-18	Capscrew SH .375" - 16 x 4.500".....	4
6	2-P-865 ⁽¹⁾	Output Gear 35T.....	1	20	329463-12X	12V Valve Cap Assembly.....	1
7	560972	Bearing Needle Roller Assembly 1.500" x 1.875 x 1.000".....	1	21	22-P-112	Gasket.....	1
8	5-P-1428 ⁽¹⁾	Input Gear 50T.....	1	22	378447-6	Capscrew SH .312" - 18 x 1.000".....	3
9	5-P-1432 ⁽¹⁾	Gear Ratio 29T.....	1	23	68-P-51	Name Plate.....	1
10	380064	Lockring.....	1	24	378422	Drive Screw.....	2
11	561026	Bearing Cone Tapered 1.181" x .9843".....	2	25	329609-3X	Output Assembly "AF".....	1
12	9-P-99	Idler Shaft 1.18".....	1	26	500897-5	Shipping Plug.....	2
13	28-P-42	O-Ring 1.051" x .070".....	1	27	378431-13	Capscrew HH .375" - 16 x 1.375".....	4
14a	14-P-82-1	Spacer 1.191" x 1.75 x .080".....	1	28	380076-07	Flat Hardened Washer .410" x .816 x .066".....	8
14b	14-P-82-1	Spacer 1.191" x 1.75 x .080".....	A.R.	29	379659	Tee .438" - 20.....	2
	14-P-82-2	Spacer 1.191" x 1.75 x .085".....	A.R.	30	329658X	Cover Kit "XK", "AF", "AZ".....	1
	14-P-82-3	Spacer 1.191" x 1.75 x .090".....	A.R.				
	14-P-82-4	Spacer 1.191" x 1.75 x .094".....	A.R.				

A.R. — As Required

⁽¹⁾ See [Page 24](#) for other Gear Options

Exploded View – 890HBFJW-B5XS

890HAFJW-B5XS
890HCFJW-B5XS
890HDFJW-B5XS
890HEFJW-B5XS
890HFFJW-B5XS
890HGFJW-B5XS
890HHFJW-B5XS

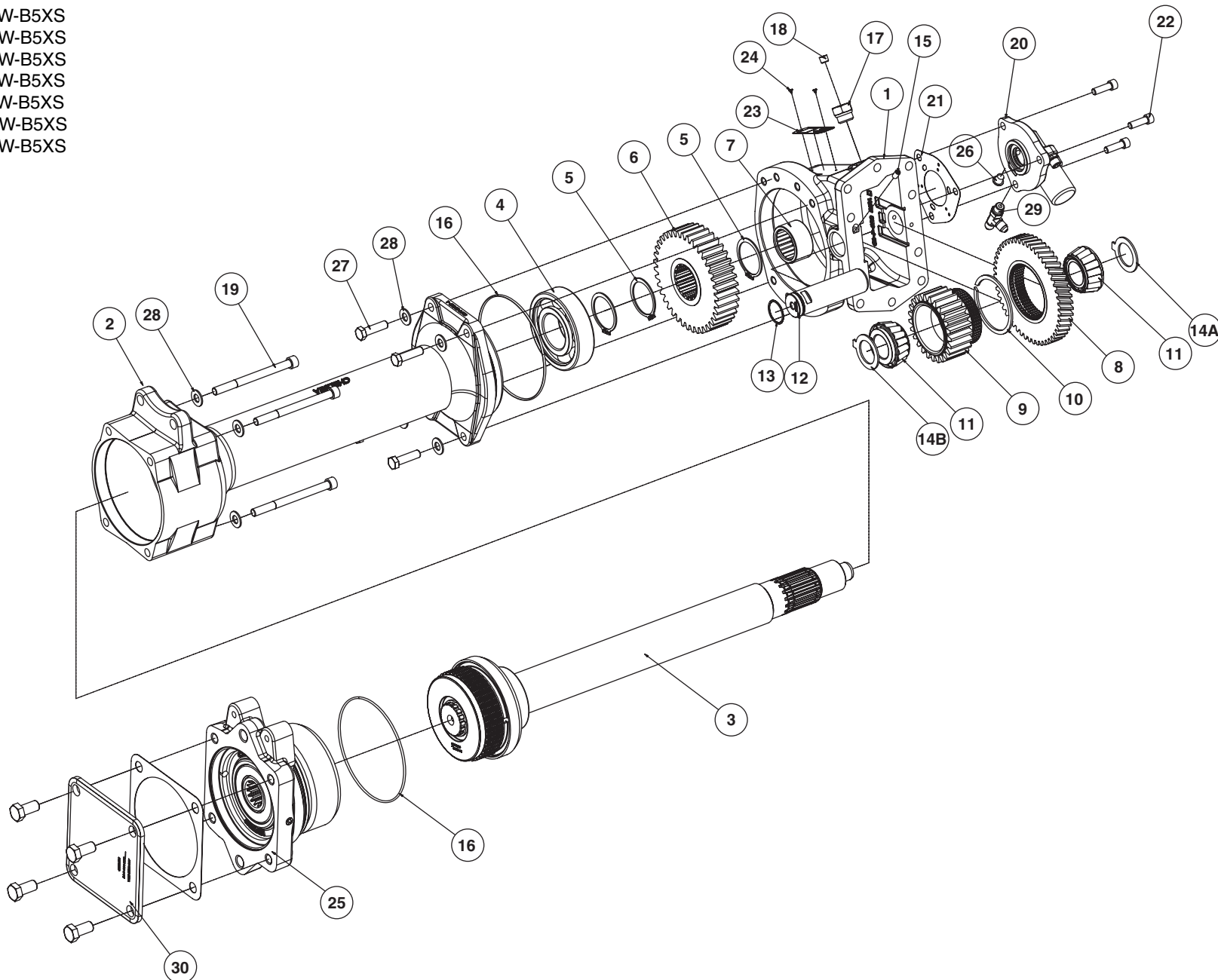

Bill of Materials

890HBFJW-B5XS

Item	Part Number	Description	Qty.	Item	Part Number	Description	Qty.
1	1-P-629	Housing.....	1	15	378452-7	Screw Set SH .250" - 20 x .500".....	1
2	54-P-22	Bearing Retainer.....	1	16	28-P-245	O-Ring 5.017" x .103".....	2
3	329607X	Drive Shaft & Clutch Assembly.....	1	17	379242	Adapter Straight .125" - 27 x .750" - 16.....	1
4	550026	Ball Bearing 1.7717" x 3.937 x .9843".....	1	18	379231	Pipe Plug .125" - 27.....	1
5	379668	Lockring.....	3	19	379433-18	Capscrew SH .375" - 16 x 4.500".....	4
6	2-P-872 ⁽¹⁾	Output Gear 39T.....	1	20	329463-12X	12V Valve Cap Assembly.....	1
7	560972	Bearing Needle Roller Assembly 1.500" x 1.875" x 1.000".....	1	21	22-P-112	Gasket.....	1
8	5-P-1428 ⁽¹⁾	Input Gear 50T.....	1	22	378447-6	Capscrew SH .312" - 18 x 1.000".....	3
9	5-P-1438 ⁽¹⁾	Gear Ratio 25T.....	1	23	68-P-51	Name Plate.....	1
10	380064	Lockring.....	1	24	378422	Drive Screw.....	2
11	561026	Bearing Cone Tapered 1.181" x .9843".....	2	25	329609-1X	Output Assembly "XS".....	1
12	9-P-99	Idler Shaft 1.18".....	1	26	500897-5	Shipping Plug.....	2
13	28-P-42	O-Ring.....	1	27	378431-13	Capscrew HH .375" - 16 x 1.375".....	4
14A	14-P-82-1	Spacer 1.191" x 1.75 x .080".....	1	28	380076-07	Flat Hardened Washer .410" x .816 x .066".....	8
14B	14-P-82-1	Spacer 1.191" x 1.75 x .080".....	A.R.	29	379659	Tee .438" - 20.....	2
	14-P-82-2	Spacer 1.191" x 1.75 x .085".....	A.R.	30	329654X	Cover Kit "XS".....	1
	14-P-82-3	Spacer 1.191" x 1.75 x .090".....	A.R.				
	14-P-82-4	Spacer 1.191" x 1.75 x .094".....	A.R.				

A.R. — As Required

⁽¹⁾ See [Page 24](#) for other Gear Options

890EAFJW-B5AF
890EBFJW-B5AF
890EDFJW-B5AF
890EEFJW-B5AF
890EFFJW-B5AF
890EGFJW-B5AF
890EHFJW-B5AF

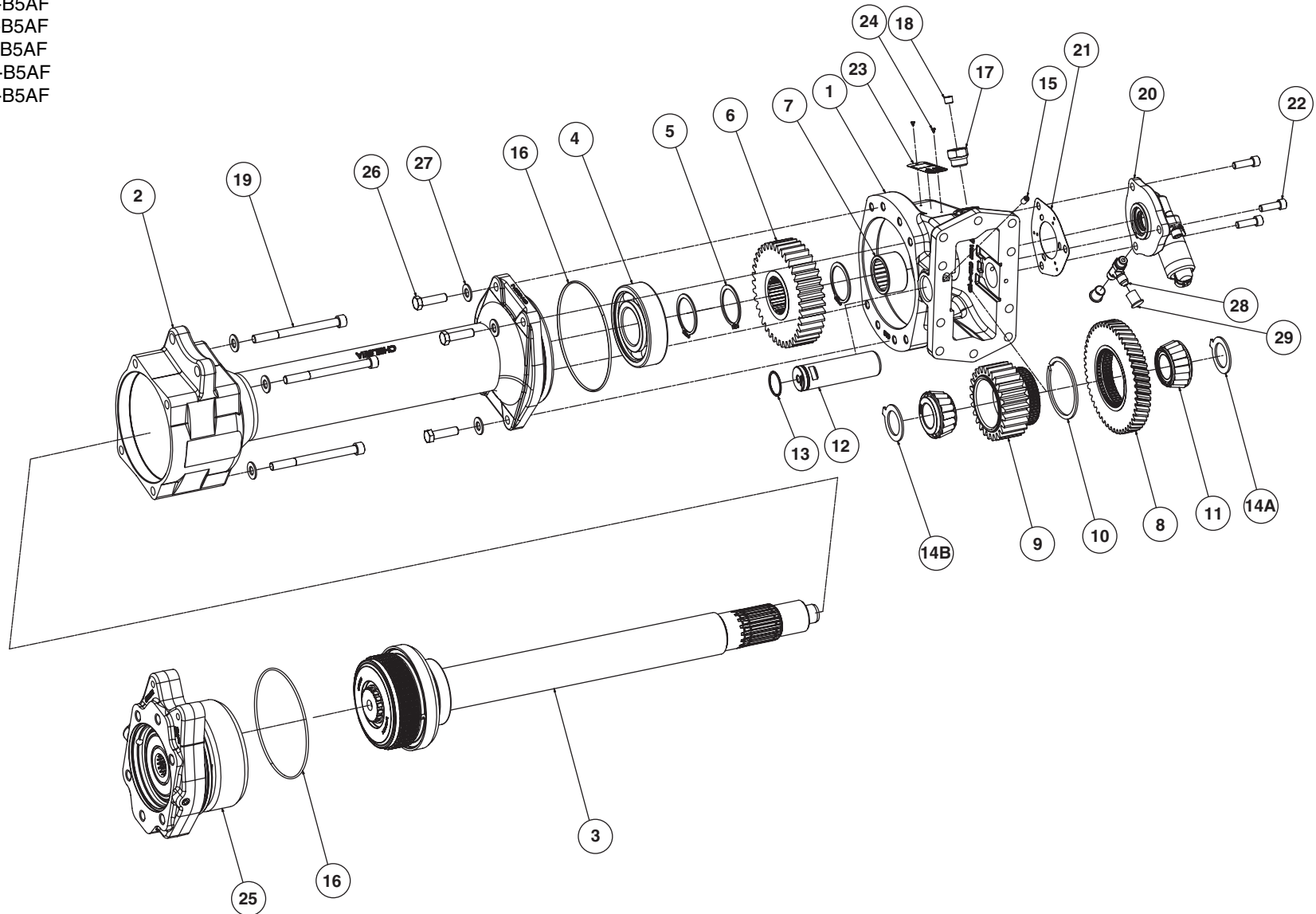

890ECFJW-B5AF

Item	Part Number	Description	Qty.	Item	Part Number	Description	Qty.
1	1-P-629	Housing.....	1	15	378452-7	Screw Set SH .250" - 20 x .500".....	1
2	54-P-22	Bearing Retainer.....	1	16	28-P-245	O-Ring	2
3	329607X	Drive Shaft & Clutch Assembly.....	1	17	379242	Adapter Straight .125" - 27 x .750" - 16.....	1
4	550026	Ball Bearing 1.7717" x 3.937 x .9843"	1	18	379231	Pipe Plug .125" - 27.....	1
5	379668	Lockring	3	19	379433-18	Capscrew SH .375" - 16 x 4.500"	4
6	2-P-873 ⁽¹⁾	Output Gear 38T.....	1	20	329463-12X	12V Valve Cap Assembly.....	1
7	560972	Bearing Needle Roller Assembly 1.500" x 1.875" x 1.000".....	1	21	22-P-112	Gasket.....	1
8	5-P-1428 ⁽¹⁾	Input Gear 50T.....	1	22	378447-6	Capscrew SH .312"- 18 x 1.000"	3
9	5-P-1439 ⁽¹⁾	Gear Ratio 26T	1	23	68-P-51	Name Plate	1
10	380064	Lockring	1	24	378422	Drive Screw.....	2
11	561026	Bearing Cone Tapered 1.181" x .9843".....	2	25	329609-3X	Output Assembly "AF"	1
12	9-P-99	Idler Shaft 1.18"	1	26	378431-13	Capscrew HH .375" - 16 x 1.375"	4
13	28-P-42	O-Ring 1.05" x .070".....	1	27	380076-07	Flat Hardened Washer .410" x .816 x .066".....	8
14A	14-P-82-1	Spacer 1.191" x 1.75 x .080"	1	28	379659	Tee .438" - 20.....	2
14B	14-P-82-1	Spacer 1.191" x 1.75 x .080"	A.R.	29	379564-2	Cap Thread .438".....	1
	14-P-82-2	Spacer 1.191" x 1.75 x .085"	A.R.				
	14-P-82-3	Spacer 1.191" x 1.75 x .090"	A.R.				
	14-P-82-4	Spacer 1.191" x 1.75 x .094"	A.R.				

A.R. — As Required

⁽¹⁾ See [Page 24](#) for other Gear Options

**S
E
C
T
I
O
N

2**

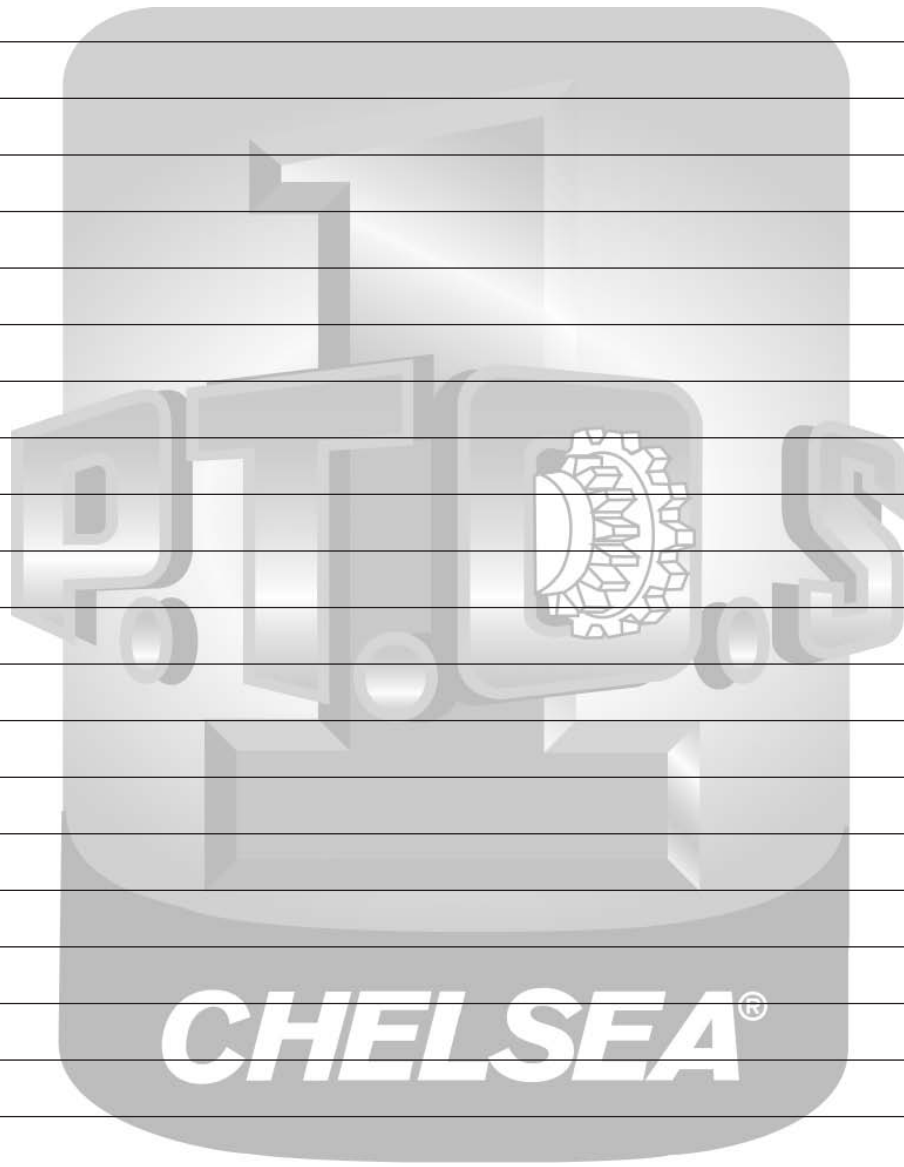

When removing the 890 Series from the transmission and after pump and all the connections have been removed, it is recommended that the P.T.O. be removed in the following sequence.

1. The Tube section (2) may need some support to remove weight from the rear Bracket to ease the removal of the two Hex Capscrews
2. Loosen the two Hex Capscrews that hold the Output Flange section of the P.T.O. (1) to the transmission Bracket. Do not completely remove at this time.
3. Start to remove the Tube Assembly of the P.T.O. by removing the four Capscrews (27) and Washers (28) that mate the Tube to the P.T.O. Housing (1)
4. Slowly slide the Tube towards the back of the transmission.
5. While securely holding the Tube section remove the two Hex Capscrews from the rear Mounting Bracket while sliding the Tube back and down from the P.T.O. Housing.
6. Remove the main P.T.O. Housing (1) from the transmission by removing the seven Capscrews.

Disassembly

1. Housing Assembly
 - 1.1. Remove T-Fitting 379659 from the Valve Cap Sub Assembly. Remove the Solenoid Valve Cap Assembly (20) from the P.T.O. housing (1) using a 1/4" Hex Bit to remove three Cap Screws (22).
 - 1.2. Remove Gasket (21) from the Pilot of Solenoid Valve Cap Assembly (20). See page 21 for break down of the Valve Cap Assembly.
 - 1.3. Remove Set Screw (15) to allow the Idler Shaft (12) to be removed.
 - 1.4. Press Idler Shaft (12) thru the aligned Washers (14A & 14B), Bearings (11) & Input/Ratio Gear (8 & 9) until it is fully unseated.
 - 1.5. Remove Tapered Roller Bearings (11) on both sides of the Input Gear Sub Assembly.
 - 1.6. **NOTE:** The Input Gear (8) and Ration Gear (9) cannot be separated due to the internal Snap Ring (10). If the Gear(s) need to be replaced, contact Chelsea Customer Service.
2. Tube Assembly Section
 - 2.1. Start by removing the O-Ring (16) from the end of the Tube (2) that mates to the main P.T.O. Housing (1).
 - 2.2. Next remove the Snap Ring (5) that retains the Output Gear (6) on the Shaft Assembly (3).
 - 2.3. Slide the Output Gear (6) off the Shaft Assembly (3).
 - 2.4. Remove the next two Snap Rings (5).
 - 2.5. At the Flange/Output end of the Tube Assembly (2) unscrew and remove the four Cap Screws (19) and Washers (28) from the Tube Assembly (2).
 - 2.6. Remove the Output Assembly (25) and O-Ring (16) from the Tube Assembly (2).
 - 2.7. Slide the Shaft Assembly (3) by pressing on the Shaft from the P.T.O. Housing (1) mating side of the Tube Assembly (2) towards the Flange/Output side of the Tube Assembly.
 - 2.8. After Output Shaft (3) has been removed from the Tube (2), remove Roller Bearing (4) from Tube (2).

3. Flange Assembly
 - 3.1. Remove the Oil Seal (F6) from the Flange Housing (F1).
 - 3.2. Next remove the Snap Ring (F5) from the Flange Housing (F1).
 - 3.3. The Output/Clutch Bell Gear (F4) can be removed at this time.
 - 3.4. Remove Snap Ring (F3) to press out Bearing (F2).
 - 3.5. Pipe Plug (F7) can be removed if required.

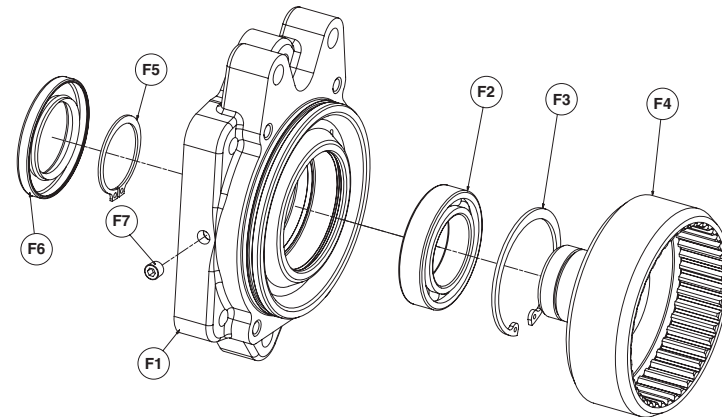

Item	Part Number	Description	Qty.
F1	21-P-717	Flange Pump "XS" S.A.E. "C" 2 or 4-Bolt	1
F2	561018	Bearing Ball 1.772" x 2.953" x .630"	1
F3	379919	Lockring	1
F4	2-P-867	Gear Output 1.250" - 14T Spline ("XS" Output)	1 or
F4	2-P-875	Gear Output 1.000" - 15T Spline ("AF" Output)	1
F5	379668	Lockring	1
F6	28-P-278	Oil Seal 2.953" x 1.772" x .315"	1
F7	379231	Plug Pipe .125" - 27	2
N.S.	28-P-259X	O-Ring 3.984" x .139" (Wet Spline Pump Mounting)	1

N.S. — Not Shown

Disassembly

4. Driveshaft & Clutch Assembly
 - 4.1 Warning the Clutch Assembly is under spring tension.
 - 4.2 To remove the Clutch Pack from the Output Shaft (C7) start by compressing the Inner Clutch Gear (C5) and removing the Snap Ring (C6).
 - 4.3 Next remove the Clutch Gear (C5), Clutch Friction Discs (C8) and Clutch Plates (C9).
 - 4.4 Remove the Spring (C10), Clutch Piston (C4), and Back-Up Clutch Cylinder (C2).
 - 4.5 Remove the O-Ring (C3) from the Clutch Piston (C4).
 - 4.6 Remove the two O-Rings (C1) on the Output Shaft (C7).
 - 4.7 Remove the Bearing Retaining Lockring (C11) and then slide the Bearing (C12) off the Output Shaft Bearing (C7).
 - 4.8 Pipe Plug (C13) can be removed if required.

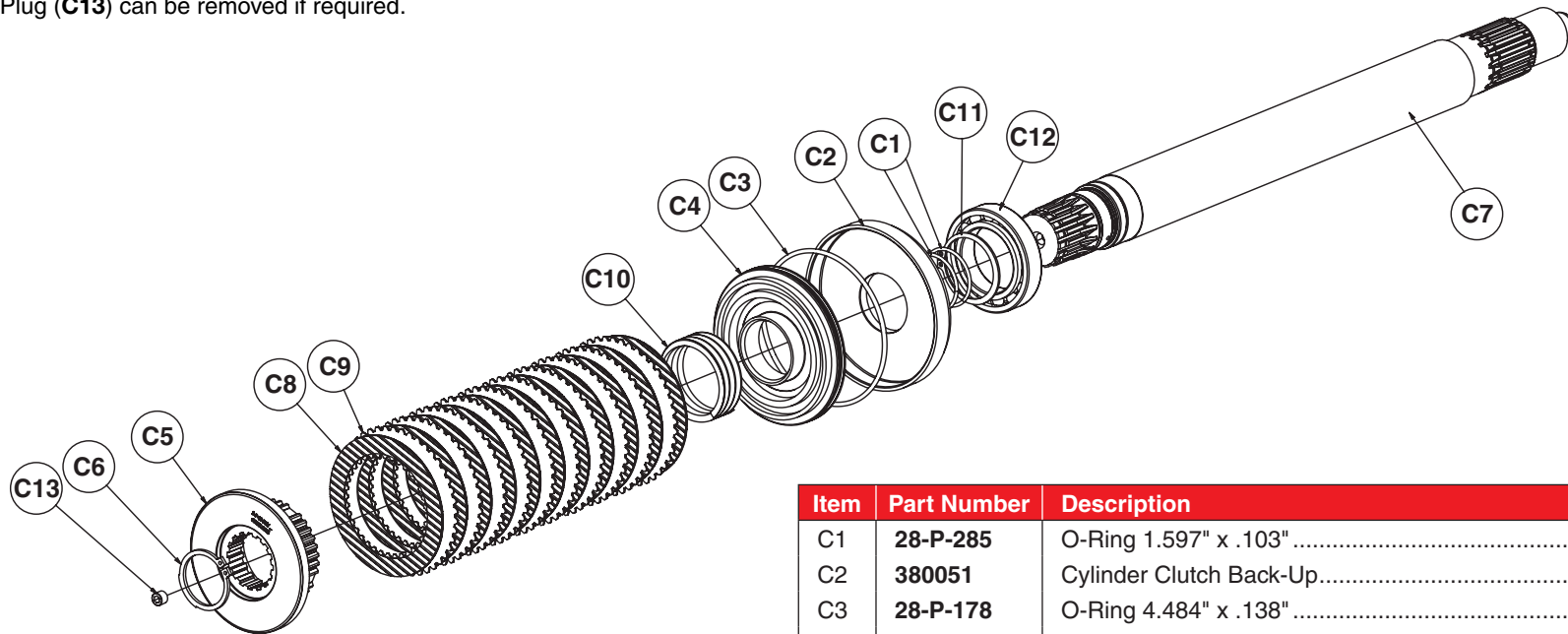

Item	Part Number	Description	Qty.
C1	28-P-285	O-Ring 1.597" x .103"	2
C2	380051	Cylinder Clutch Back-Up.....	1
C3	28-P-178	O-Ring 4.484" x .138"	1
C4	380110X	Piston Clutch.....	1
C5	2-P-858	Gear Output 36 Tooth	1
C6	380069	Lockring	1
C7	3-P-1007	Shaft Output.....	1
C8	379485	Disc Friction	11
C9	380065	Plate Clutch	10
C10	37-P-62	Spring 2.140" x 1.729"	1
C11	380070	Lockring	1
C12	561028	Bearing Ball 1.969" x 3.150" x .630"	1
C13	379231	Plug Pipe .125" - 27	1

Disassembly

5. Valve & Cap Assembly
 - 5.1. Carefully remove the Retaining Ring (D) and Washer (C). Visually inspect the Oil Seal (B) now. If you see signs of wear or leakage, remove the Oil Seal (B).

Important: Do not nick the Seal Bore. This could result in leakage or further damage to the P.T.O.
 - 5.2. Remove the Solenoid Valve Socket Capscrew (E).
 - 5.3. Remove the Solenoid Valve (G) from the Cap. Be careful not to damage the Seal. Check the O-Rings for damage. If they are damaged, replace the O-Rings.

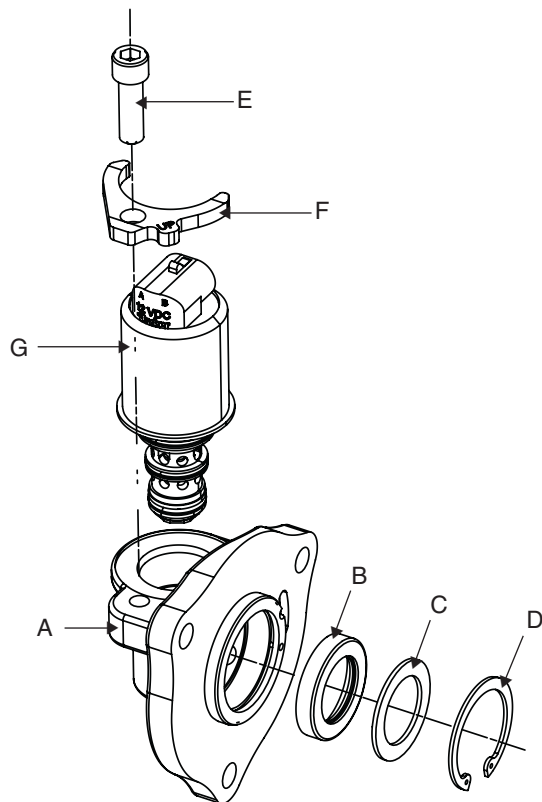

Item	Part Number	Description	Qty.
39	329442-12X	Valve & Cap Assembly (12V) ("KV" Pitch Only).....	1 or
	329442-24X	Valve & Cap Assembly (24V) ("KV" Pitch Only).....	1
	329463-12X	Valve & Cap Assembly (12V) ("FJ" Pitch Only).....	1 or
	329463-24X	Valve & Cap Assembly (24V) ("FJ" Pitch Only).....	1
A	34-P-143	Valve Cap	1
B	28-P-119	Oil Seal (Hi Pressure).....	1
C	378811	Washer	1
D	378849	Retaining Ring	1
E	378447-6	Sockethead Capscrew .312" - 18 x 1.00"	1
F	379995	Clamp ("KV") Included with 379993 Valve	1 or
	380012	Clamp ("FJ") used with 380011 Valve.....	1
	380124	Clamp ("FJ") used with 380123 Valve.....	1
G	379993-12	Hydraulic Valve (12V) ("KV") (White Connector).....	1 or
	379993-24	Hydraulic Valve (24V) ("KV") (Black Connector)	1
	380011-12	Hydraulic Valve (12V) ("FJ") (White Side Connector)	1 or
	380011-24	Hydraulic Valve (24V) ("FJ") (Black Side Connector).....	1
	380123-12	Hydraulic Valve (12V) ("FJ") (White Connector Top) (New Style)	1 or
	380123-24	Hydraulic Valve (24V) ("FJ") (Black Connector Top) (New Style)	1

1. Be sure selected parts are those called out on the Pick List.
2. Visually inspect parts before assembly for flaws.
3. The terms OUTPUT and DRIVE are used interchangeably.
4. Lubricate most bearings before assembly. Use MELCOMOL ‘Y’, EP-2 or equal.
5. When assembling bearings, always place the bearings rounded end into the part.
6. Use Parker O-Lube or equal to lubricate O-Rings and seals before assembly.
7. When assembling O-Rings, do not roll it into their grooves. Use an O-Ring tool for assembly. O-Rings are not to be twisted or damaged.
8. When assembling seals, the seal side is opposite the flat side which is identified by a stamped part number. The seal side must be in the direction of the oil/air pressure.

Assembly

1. Valve & Cap Assembly
 - 1.1. If the Valve Assembly Oil Seal (B) was worn or damaged, replace it now. Lubricate a new Seal (B). Install it carefully with the proper driver. Next install the Washer (C) and Retaining Ring (D). **Important:** Avoid nicking the P.T.O. Housing (1). This could cause leakage or other P.T.O. damage.
 - 1.2. Lubricate and attach the Solenoid Valve (G) to the Cap.
 - 1.3. Next install the Clamp (F) and Sockethead Capscrew (E). Secure the Solenoid to the Valve Cap (A) with Hex Capscrews (E). Torque them to 48 – 72 Lbs. in. (5.4 – 8.1 N.m. or 55 – .82 Kgm).
 - 1.4. Place a new Valve Cap Gasket (21) on the Valve Assembly. Make sure the holes are aligned. **Caution:** Do not use Sealing Compounds. It could affect the correct operation of the transmission.
 - 1.5. Attach the Valve Assembly (20) to the P.T.O. Housing (1). Tighten the three Capscrews (22) and torque them to 16 – 20 Lbs. ft. (22 – 27 N.m. or 2.2 – 2.8 Kgm).

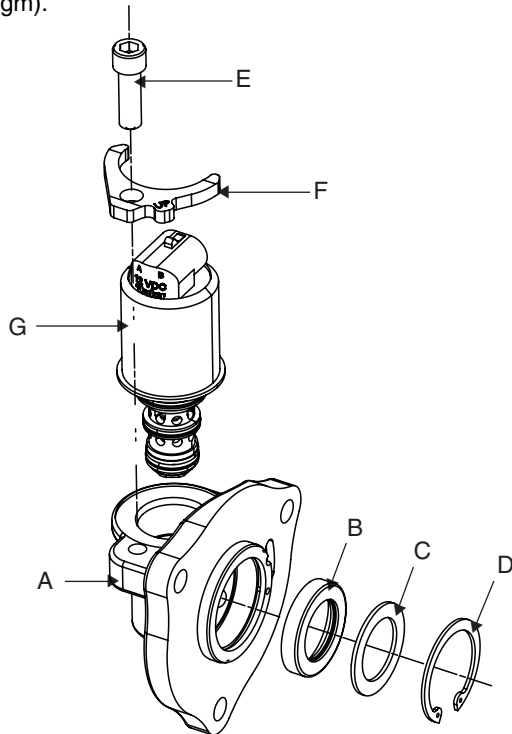

Item	Part Number	Description	Qty.
39	329442-12X	Valve & Cap Assembly (12V) (“KV” Pitch Only).....	1 or
	329442-24X	Valve & Cap Assembly (24V) (“KV” Pitch Only).....	1
	329463-12X	Valve & Cap Assembly (12V) (“FJ” Pitch Only).....	1 or
	329463-24X	Valve & Cap Assembly (24V) (“FJ” Pitch Only).....	1
A	34-P-143	Valve Cap	1
B	28-P-119	Oil Seal (Hi Pressure).....	1
C	378811	Washer	1
D	378849	Retaining Ring	1
E	378447-6	Sockethead Capscrew .312" - 18 x 1.00"	1
F	379995	Clamp (“KV”) Included with 379993 Valve	1 or
	380012	Clamp (“FJ”) used with 380011 Valve.....	1
	380124	Clamp (“FJ”) used with 380123 Valve.....	1
G	379993-12	Hydraulic Valve (12V) (“KV”) (White Connector).....	1 or
	379993-24	Hydraulic Valve (24V) (“KV”) (Black Connector)	1
	380011-12	Hydraulic Valve (12V) (“FJ”) (White Side Connector)	1 or
	380011-24	Hydraulic Valve (24V) (“FJ”) (Black Side Connector).....	1
	380123-12	Hydraulic Valve (12V) (“FJ”) (White Connector Top) (New Style)	1 or
	380123-24	Hydraulic Valve (24V) (“FJ”) (Black Connector Top) (New Style)	1

Assembly

2. Drive Shaft Clutch Assembly
 - 2.1 Place Bearing (C12) onto Shaft (C7). Using a Press Tool, press the Bearing (C12) onto the Shaft (C7) allowing the Press Tool to fully seat against the end of the Shaft (C7).
 - 2.1.1. This will position the bearing properly for Snap-Ring installation.
 - 2.2. Place Snap-Ring (C11) over the end of Shaft (C7). Using Snap-Ring Pliers spread the legs of Snap-Ring over the Shaft and into the groove. Visually check to assure Snap-Ring is fully seated.
 - 2.3. Place O-Ring Sleeve over the end of Shaft (C7) allowing it to seat on the end of the Shaft beyond the lube hole. Lubricate O-Ring (C1) and slide over the O-Ring sleeve down to install into the groove in the Shaft (C7). Lubricate and place a second O-Ring (C1) onto the sleeve. Pull O-Ring Sleeve up in front of the lube hole. Proceed to slide the O-Ring (C1) down to install into the groove in the Shaft (C7).
 - 2.4. Lubricate O-Ring (C3) and install into the groove on the outer diameter of Clutch Piston (C4). Install Clutch Piston into the Back-Up Cylinder (C2). Place the Sub-Assembly onto the Shaft (C7) seating the Back-Up Cylinder (C2) against the shoulder of Shaft (C7).
 - 2.5. Install Clutch Gear onto Clutch Gear
 - 2.6. Alternately place ELEVEN Friction Discs (C8) and TEN Clutch Plates (C9) onto Inner Clutch Gear (C5) beginning and ending with a Friction Disc (C8).
 - 2.7. Slide the spring (C10) over the end of Shaft (C7) and Pilot onto the Clutch Piston 380053.
 - 2.8. Hold the completed Friction Disc / Clutch Plate Pack onto the Inner Clutch Gear (C5) and slide the Sub-Assembly onto the spline portion of Shaft (C7). Press the Sub-Assembly down to compress spring (C10).
 - 2.9. Install Snap-Ring (C6) into the groove of Shaft (C7) to retain the Clutch Pack Sub-Assembly.
 - 2.10. Install Plug (C13) (0.125"-27 NPT) into the end of Shaft (C7) to 8-12 Lbs. ft. (10.8-16.3 N.m.) torque.

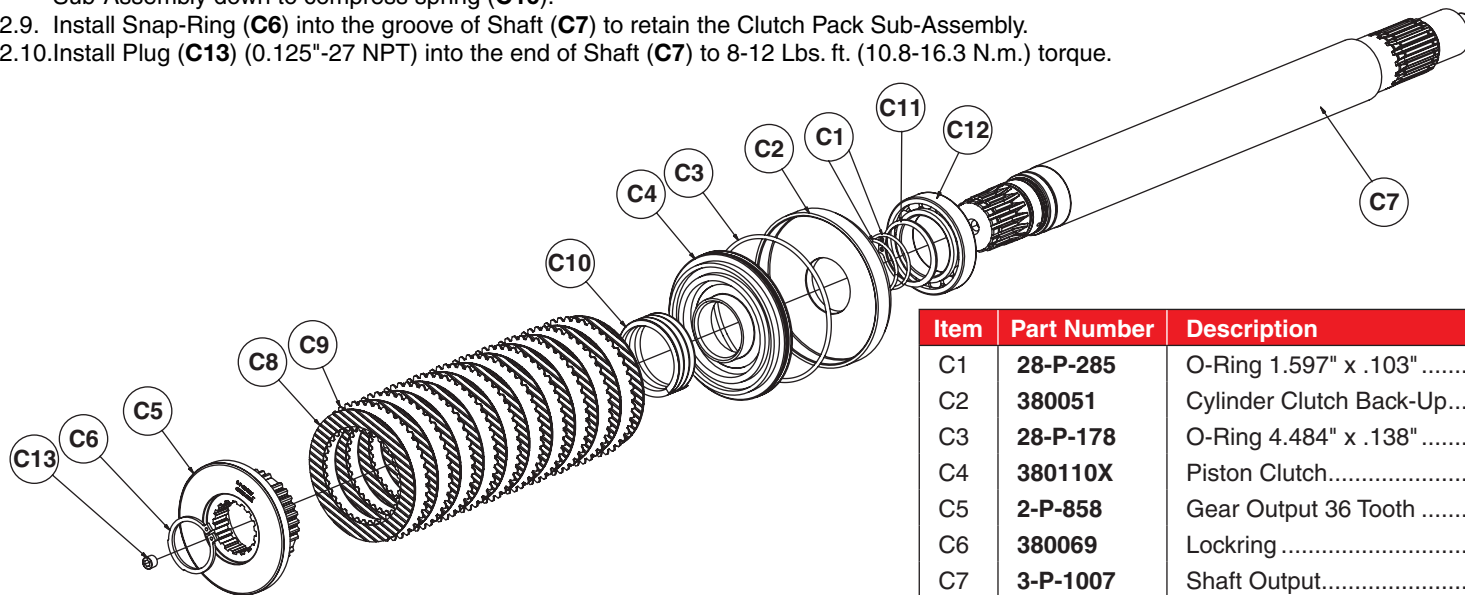

Item	Part Number	Description	Qty.
C1	28-P-285	O-Ring 1.597" x .103"	2
C2	380051	Cylinder Clutch Back-Up.....	1
C3	28-P-178	O-Ring 4.484" x .138"	1
C4	380110X	Piston Clutch.....	1
C5	2-P-858	Gear Output 36 Tooth	1
C6	380069	Lockring	1
C7	3-P-1007	Shaft Output.....	1
C8	379485	Disc Friction	11
C9	380065	Plate Clutch	10
C10	37-P-62	Spring 2.140" x 1.729"	1
C11	380070	Lockring	1
C12	561028	Bearing Ball 1.969" x 3.150" x .630"	1
C13	379231	Plug Pipe .125" - 27	1

Assembly

3. Flange Assembly

- 3.1. Place Bearing (F2) into the Pump Flange (F1). Using a Press Tool, press the Bearing (F2) into the Pump Flange (F1) until fully seated. Using Snap-Ring Pliers compress the legs of Snap-Ring (F3) and install into the Pump Flange (F1) to secure the Bearing. Lubricate and install O-Ring 28-P-245 into the groove located on the Male Pilot Diameter of the Pump Flange (F1).
- 3.2. Install outer Clutch Gear (F4) into Bearing (F2) (slip fit) in the Pump Flange (F1). Rotate the Cap & Gear Assembly with Snap-Ring groove exposed. Using Snap-Ring Pliers spread the legs of Snap-Ring (F5) over the outer Clutch Gear Hub and into the groove. Visually check to assure Snap-Ring is fully seated.
- 3.3. Place the proper Oil Seal Slide Tool into the Spline end of the outer Clutch Gear. Slide the Oil Seal (F6) over the Slide Tool. Pilot Seal Driver over the Seal Slide. Press the Oil Seal (F6) into Pump Flange Seal Bore flush with cast surface.
- 3.4. Install Plug (F7) (0.125-27 NPT) into both sides of the Pump Flange (F1), torque to 8-12 Lbs. ft.

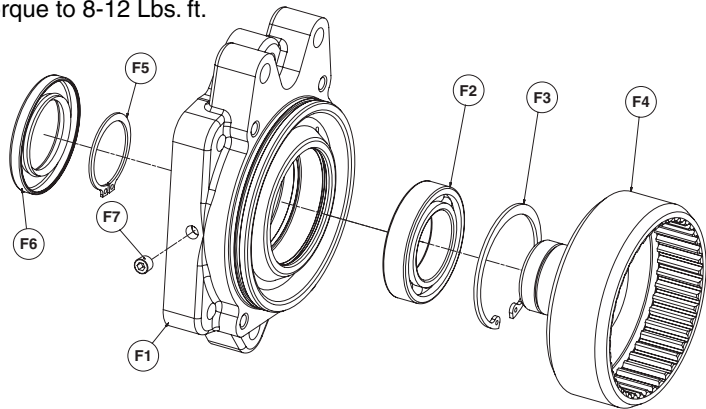

4. Shaft & Tube Assembly

- 4.1. Position Bearing (4) onto the Bearing Bore of tube (2). Using a Bearing Driver, press Bearing (4) until it is fully seated against the Bearing Backing Shoulder within Tube (2).
- 4.2. Insert the Output Shaft/Clutch Pack Sub-Assembly (3) into the outer Clutch Gear of the Pump Flange Output Sub-Assembly. **NOTE:** The Clutch Pack Plates & Discs may require alignment for ease of assembly with outer Clutch Gear.
- 4.3. Slip the Tube (2) over the Output Shaft/Pump Flange Output Sub-Assemblies aligning with Bearing 550026. Rotate Tube (2) to align Thru Holes to Threaded Holes in the Pump Flange. Use caution when assembling Tube onto the Pump Flange Pilot to prevent O-Ring damage. Insert Alignment Tool through the Bracket Mounting Holes in Tube (2) and into the C'bored Threaded Holes in the Pump Flange.
- 4.4. Place four Washers (28) onto four Cap Screws (27). Secure Tube (2) to the Pump Flange Output Sub-Assembly by installing FOUR Cap Screws with Washers, torque the screws to 30-35 Lbs. ft.
- 4.5. Using Snap-Ring Pliers expand the legs of Snap-Ring (5) over Shaft (2) and install into groove securing the Tube/Bearing Sub-Assembly to the Shaft. Using Snap-Ring Pliers expand the legs of Snap-Ring (5) over Shaft (2) and install into groove. Visually check to assure the Snap-Ring (5) is fully seated.
- 4.6. Lubricate and install O-Ring (16) into the groove located on the Male Pilot Diameter of Tube (2).
- 4.7. Place the Output Gear (6) over the end of the Shaft (3), align Spline and slide the Gear into place shouldering the Gear on the Snap-Ring.
- 4.8. Using Snap-Ring Pliers expand the legs of Snap-Ring (5) over Shaft (3) and install into groove. Visually check to assure the Snap-Ring (5) is fully seated.

Item	Part Number	Description	Qty.
F1	21-P-717	Flange Pump "XS" S.A.E. "C" 2 or 4-Bolt	1
F2	561018	Bearing Ball 1.772" x 2.953" x .630"	1
F3	379919	Lockring	1
F4	2-P-867	Gear Output 1.250" - 14T Spline ("XS" Output)	1 or
F4	2-P-875	Gear Output 1.000" - 15T Spline ("AF" Output)	1
F5	379668	Lockring	1
F6	28-P-278	Oil Seal 2.953" x 1.772" x .315"	1
F7	379231	Plug Pipe .125" - 27	2
N.S.	28-P-259X	O-Ring 3.984" x .139" (Wet Spline Pump Mounting)	1

N.S. — Not Shown

Assembly

5. Housing Assembly
 - 5.1. Using a Bearing Drive Tool install Caged Needle Roller Bearing (7) into P.T.O. Housing (1).
 - 5.2. Install Adapter Plug (17) into P.T.O. Housing (1) using a 7/8" Socket and torque to 25-30 Lbs. ft.
 - 5.3. Install Pipe Plug (18) into Adapter (17) Plug using a 3/16" Hex Bit and torque to 8-12 Lbs. ft.
 - 5.4. Place a Tapered Roller Bearing Cone (11) into both side bores of the Input Gear Sub-Assembly (8, 9 & 10).
 - 5.5. Place Tabbed Thrust Washer (14A) into the closed end of Housing (1) at the Idler Shaft Hole making sure the tab is located in the slot. Place the Input Gear Sub-Assembly & Bearings into the opening of the Housing (Input Gear towards the closed end of the Housing). Select and place a single Tabbed Washer (14B) to give proper Tapered Bearing endplay and insert the Washer making sure the tab is fully seated into the slot.
 - 5.6. Place Alignment Bar thru the idler Shaft Hole in Housing 1-P-629 (1) to align the Washers (14A & B), Bearings (11) and Input Gear (8, 9 & 10).
 - 5.7. Lube O-Ring (13) and install into the groove on the Idler Shaft (12). Locate alignment line on the threaded end of the Shaft. Place the Idler Shaft into the Housing Idler Hole so the alignment line is parallel and closest to the Housing mounting surface. Press Idler Shaft (12) thru the aligned Washers, Bearings and Input Gear until it is fully seated.
 - 5.8. Install Set-Screw (15) to 30 in-lbs max torque to lock the Idler Shaft (12) in place.
 - 5.9. Place the Gasket (21) onto the Pilot of Solenoid Valve Cap Sub-Assembly (21).
 - 5.10. Install the Solenoid Valve Cap Sub-Assembly (21) with the Solenoid oriented downward and to the right (threaded hole upward to the right) onto the P.T.O. Housing (1) using a 1/4" Hex Bit to secure THREE Cap Screws (22) and torque to 24-28 Lbs. ft.
 - 5.11. Install and secure T-fitting (29) into the Valve Cap Sub-Assembly (21).
6. Mating P.T.O. Housing and Tube Assembly
 - 6.1. Mate the Housing/Input Gear Sub-Assembly into the Tube/Output Gear Sub-Assembly. Use caution when assembling the Tube pilot into the P.T.O. Housing to prevent O-Ring damage.
 - 6.2. There are two possible orientations of the P.T.O. Housing Sub-Assembly to the Tube. Use the one noted when Assembly was first Disassembled
 - 6.3. Place Washer (28) onto Hex Head Screws (27). Fasten the Tube to the P.T.O. Housing using a 9/16" Hex Socket to secure the FOUR Hex Head Screws (27) with Washers and torque to 30-35 Lbs. ft.

**S
E
C
T
I
O
N

3**

Electrical Installation Sketch without E.O.C. for 890/892 Series (SK-459 Rev C)

Strip Wire Ends .25" Prior To Installing In Spade Terminal or Butt Connector (As Necessary)
 Reference Kit 329024-12X For 12 Volt Installation.
 Reference Kit 329024-24X For 24 Volt Installation.

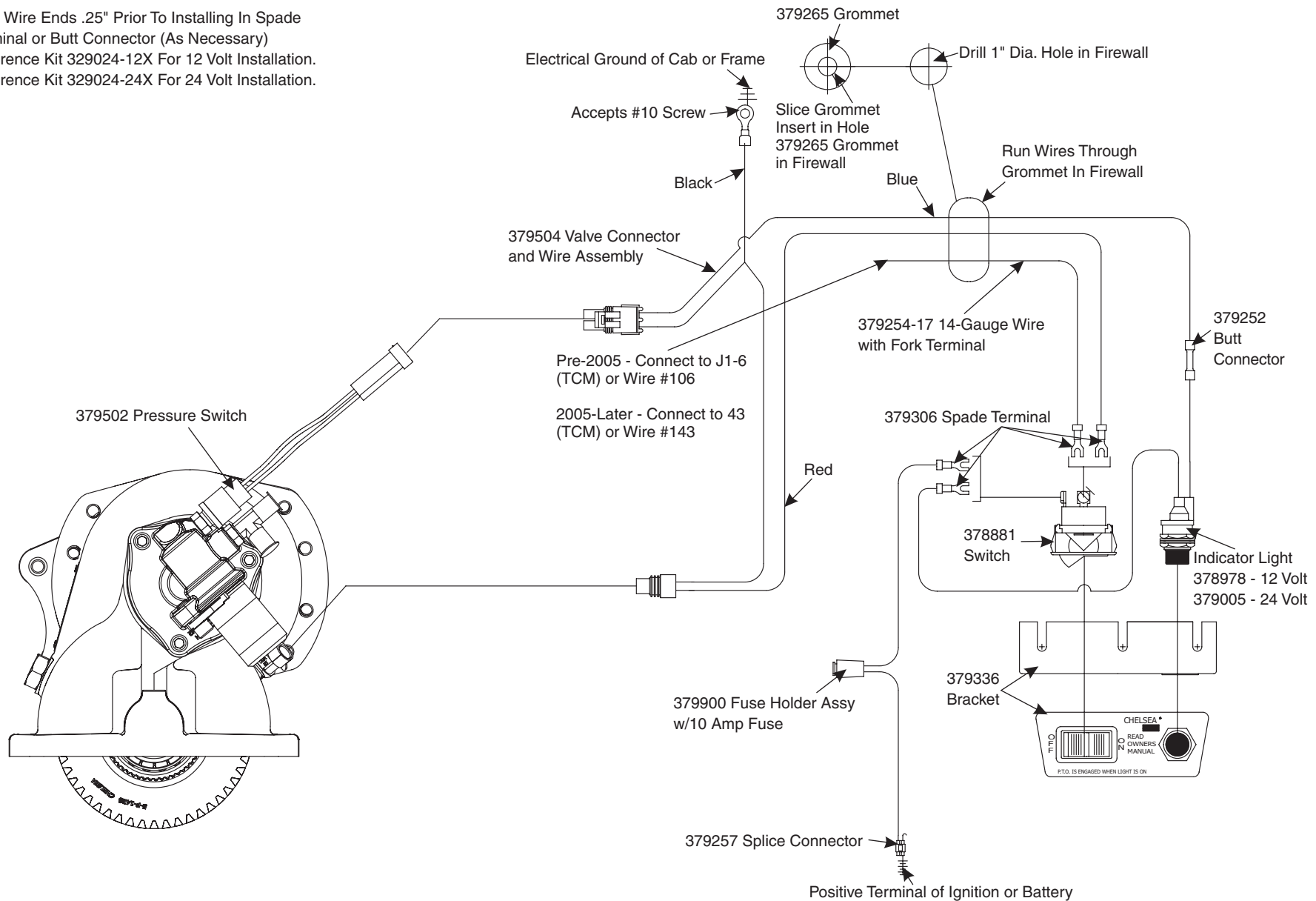

Hose Installation Sketch for 890/892 Series (SK-504)

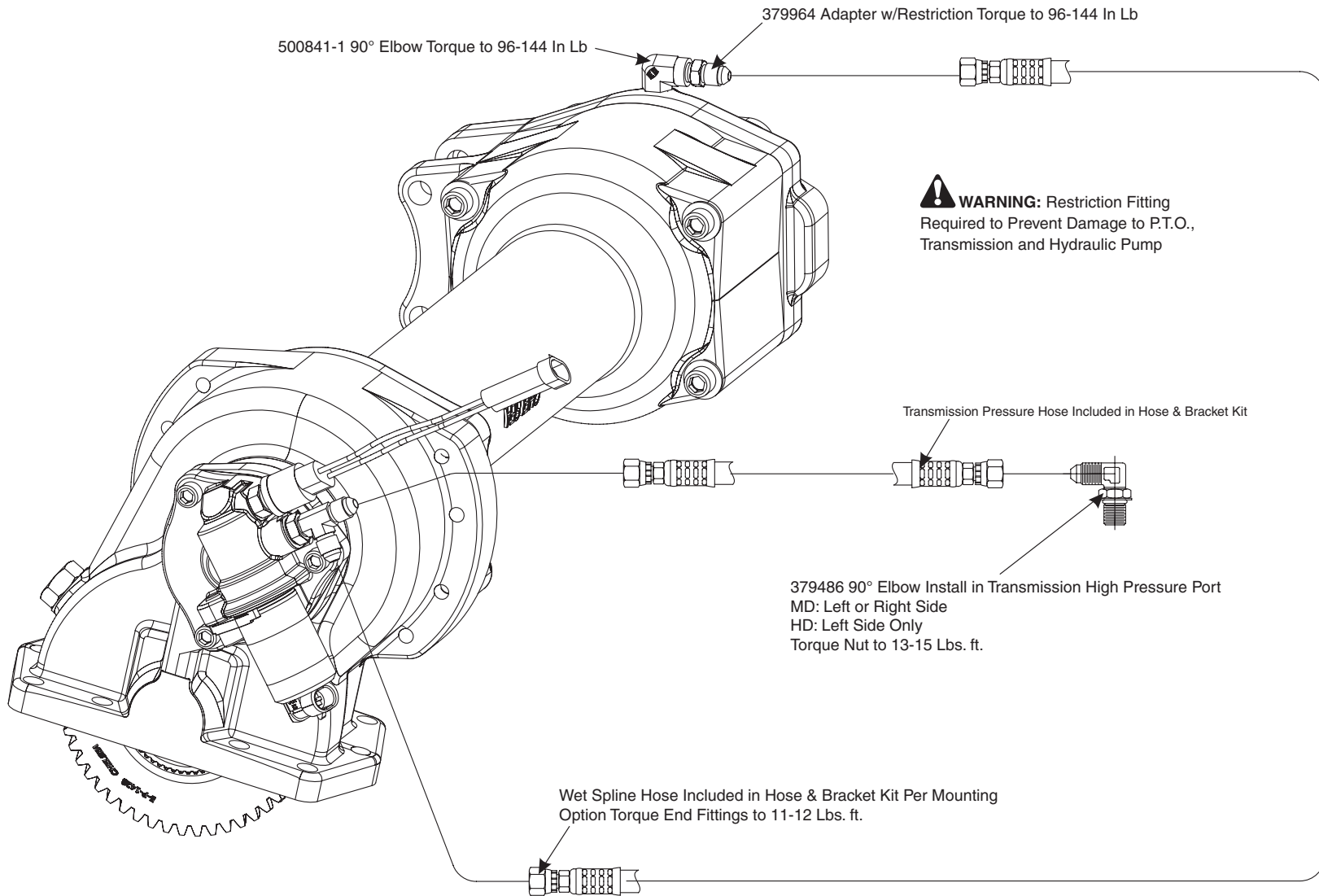

Torque Chart**Service Manual
890 Series**

Location	Torque (English)	Torque (Metric)
Idler Pin Set Screw	20 - 30 In. Lbs.	2 - 3 N.m.
Tube Assembly Cap Screws	30 - 35 Lbs. ft.	41 - 48 N.m.
Driveshaft Pipe Plug	8 - 12 Lbs. ft.	11 - 16 N.m.
Speed Sensor Port		
With E.O.C. (379243)	25 - 30 Lbs. ft.	34 - 41 N.m.
Without E.O.C.		
O-Ring Boss Plug (379242)	25 - 30 Lbs. ft.	34 - 41 N.m.
Pipe Plug (379231)	8 - 12 Lbs. ft.	11 - 16 N.m.
Valve Cap Assembly	24 - 28 Lbs. ft.	33 - 38 N.m.
Hydraulic Valve Clamp	96 - 120 In. Lbs.	11 - 13 N.m.
Shaft Nut "AB", "AC", "XV" (380486)	80 Lbs. ft.	109 N.m.

Gear Chart**Service Manual
890 Series**

GEAR DESIGNATOR	INPUT GEAR	NO. TEETH A	RATIO GEAR	NO. TEETH B	OUTPUT GEAR	NO. TEETH C
890*AFJ	5-P-1428	50	5-P-1429	24	2-P-862	40
890*BFJ	5-P-1428	50	5-P-1438	25	2-P-872	39
890*CFJ	5-P-1428	50	5-P-1439	26	2-P-873	38
890*DFJ	5-P-1428	50	5-P-1440	27	2-P-874	37
890*EFJ	5-P-1428	50	5-P-1432	29	2-P-865	35
890*FFJ	5-P-1428	50	5-P-1433	31	2-P-866	33
890*GFJ	5-P-1428	50	5-P-1457	33	2-P-888	31
890*HFJ	5-P-1428	50	5-P-1455	34	2-P-8881	30

**S
E
C
T
I
O
N

4**

Mounting the P.T.O. on the Transmission

Refer to HY25-1890-M1/US for Complete Installation Information

1. Begin by draining the oil from the transmission. Use caution, since the oil may be hot (**Fig. 1**).
2. Remove the P.T.O. aperture plate with a 15mm socket (**Fig. 2**).
3. Remove the gasket and clean the aperture surface (**Fig. 3**).

NOTE: Do not reuse the gasket that comes with the transmission.

4. Using a screwdriver, install the dowel pins until they bottom out (**Fig. 4**).

NOTE: Do not use sealing compounds because they are generally incompatible with automatic transmission fluid.

5. Install the special gasket over the guide pins. The ribbed surface should face outward, toward the installer (**Fig. 5**).

NOTE: To ensure proper backlash and sealing of P.T.O. to transmission, only use gasket furnished with the P.T.O.

6. Install the remaining capscrews. Torque all to 40 - 50 Lbs. ft. (54 - 68 N.m. or 5.5 - 6.9 Kg.m) (**Fig. 6**).
7. Securely attach the high pressure line to the P.T.O. valve "T" fitting (1), torque to 11-12 Lbs. ft. [15-16 N.m.] (**Fig. 7**) (**Fig. 7a**).

NOTE: For 890 Series see SK-504 [page 21](#) for complete plumbing installation of the transmission pressure hose and the wet spline hose.

8. Install elbow fitting supplied with P.T.O. into transmission main pressure port and torque nut to 13 - 15 Lbs. ft. or 156-180 pds-in.

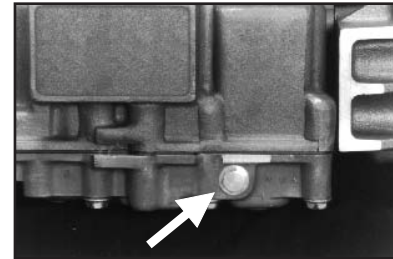

Fig. 1

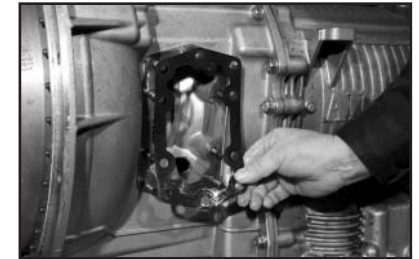

Fig. 5

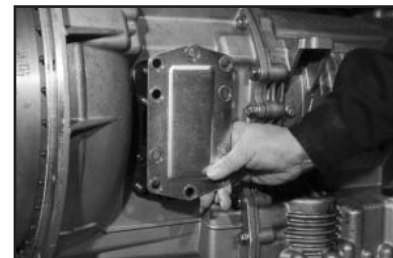

Fig. 2



Fig. 6

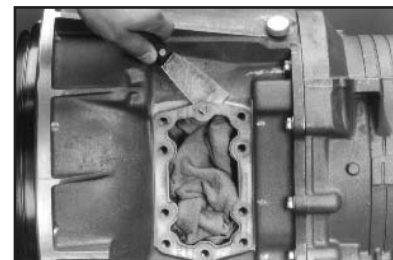

Fig. 3

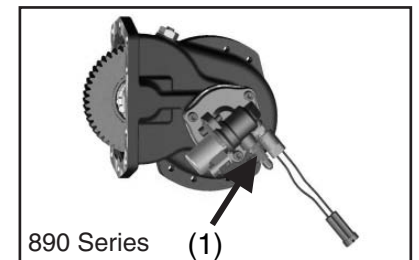

Fig. 7

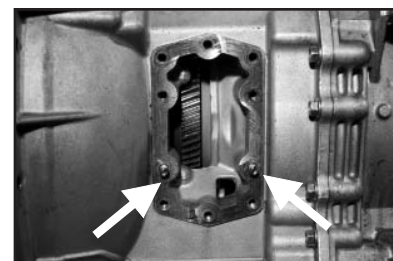

Fig. 4

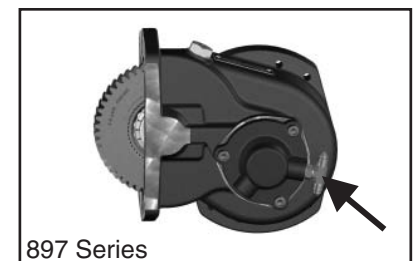

Fig. 7a

9. Securely attach the high pressure line to the elbow fitting at the transmission high pressure port and torque to 11-12 Lbs. ft. [15-16 N.m.]. This fitting is included with the P.T.O. (**Fig. 8**).

NOTE: See SK-504 [page 21](#) for complete plumbing installation of the transmission hose and the wet spline hose.

10. The 3 bolts on the transmission that will line up with the bracket must be removed. New longer Bolts (380075 M12-1.75" x 55mm) will be used for mounting the bracket to the transmission for all transmissions except 3000 Series w/Retarders. For 3000 Series w/Retarder use bolt 380364 (M12-1.75" x 140mm) (**Fig. 9 & 9a**).

NOTE: See Bracket Installation Chart on page 19 of HY25-1890-M1/US Manual

11. The tube assembly is lined up and inserted into the Input Housing. As this is done, the bolts for the bracket should be started into the rear of the transmission (**Fig. 10**).
12. As soon as at least 1 bolt is started, the tube assembly cannot fall. The unit can be aligned and slipped together with the transmission taking the weight (**Fig. 11**).

NOTE: When attaching the tube to the input housing use 4 NEW cap screws supplied with the P.T.O.

13. The 4 Hex Head Cap Screws (378431-13, 3/8"-16 x 1.375") and flatwashers 380076-07 make the final attachment between the input housing and the tube assembly. Torque the Cap Screws to 30-35 Lbs. ft. [41-47 N.m.] (**Fig. 12**).
14. The 3 longer bolts in the transmission should be Torqued as Follows:
3000 Family - 66-81 Lbs. ft. [90-110 N.m.]
4000 Family - 74-89 Lbs. ft. [100-120 N.m.]
(**Fig. 13**).
15. To complete installation of the P.T.O. see SK drawings on pages 15-17 for wiring and plumbing installation.

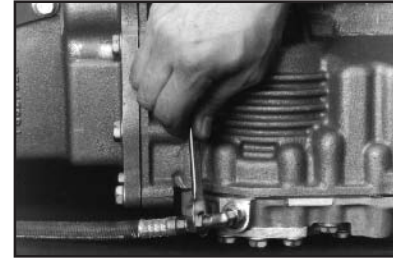

Fig. 8

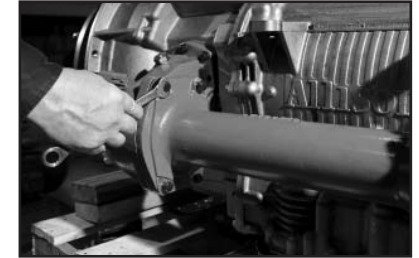

Fig. 12



Fig. 9



Fig. 9a

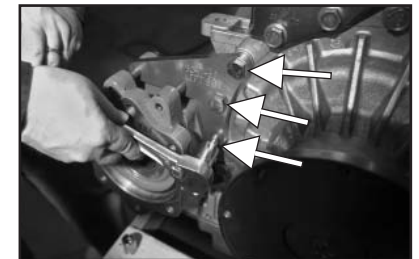

Fig. 13

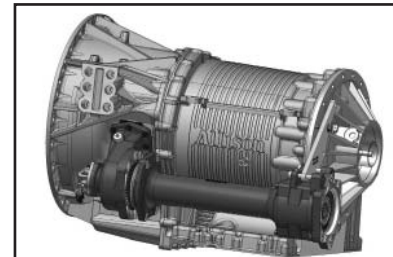

Fig. 10



Fig. 11

16. When installing pumps use O-Ring supplied with P.T.O. between pump and P.T.O. output. Torque pump bolts to proper torque specifications. Refer to page 3 of HY25-1890-M1/US manual for proper pump bracket support requirements.

NOTE: Do not use gasket with O-Ring

As with all auxiliary power systems, there are different concerns and needs with varying applications, duty cycles, and driven equipment Chelsea endeavors to provide options that will ensure trouble free use of our products and system solutions.

For customers that would like an extra level of protection from pump seal leaks, there are double sealed pumps available from Parker to satisfy your needs. Please verify your requirements with your Parker/Chelsea P.T.O. and Pump experts.

WARNING: Do not run P.T.O. w/wet spline output option if pump is not installed and connected to hydraulic system. Failure to do so may damage P.T.O./ Transmission.

**S
E
C
T
I
O
N

5**

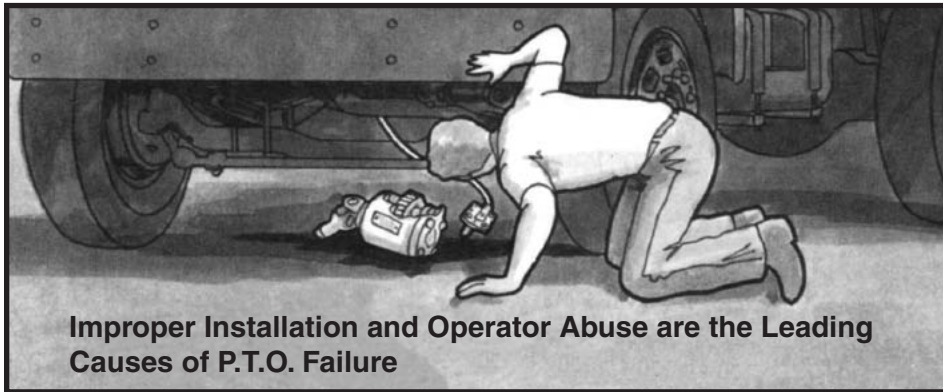

The Chelsea P.T.O. is designed and built to meet the rugged demands of the Mobile Equipment Industry. With proper use and maintenance, the Chelsea P.T.O. will provide a long service life, both on-highway and off. Yet, if a problem does arise, it is important to diagnose its causes and correct it at once.

The first place to look when troubleshooting a P.T.O. failure is in the application itself. Repeated or premature failure may be a sign of an incorrect application. This can be discovered by using the Chelsea HY25-3001/US General Information Catalog or HY25-3000/US Applications Catalog. Check to see if the proper P.T.O. was specified for the transmission, then find out if the torque handling capabilities of the P.T.O. are satisfactory for the job being done. A P.T.O. works best when it is properly specified for the transmission and job requirement.

If the P.T.O. was correctly specified and then failed prematurely, there are two likely causes: improper installation and/or operator misuse. These are tough problems because they involve people as well as product. An improperly installed P.T.O. can normally be identified immediately by the sound it makes. It will “whine” if installed too tightly, or “clatter” if it is installed too loosely. Sometimes, the vehicle itself may contribute enough noise to mask the sound of the P.T.O. and one may not notice the problem.

If a problem is allowed to continue, then damage to the P.T.O. will result. A unit that has been mounted too loosely could result in broken gear teeth. A unit that is mounted too tightly could result in premature wear to the gear teeth. Also, when a P.T.O. is installed without enough filler blocks, spacers, or gaskets between it and the transmission, a deep wear pattern will occur on the gear teeth. These patterns will lead to fatigue and early tooth failure. To help prevent this from occurring, always test the P.T.O. for noise just after it is installed.

Whatever the reason for a P.T.O. failure, there will be confusion over who, or what, is at fault. More than likely the product will be blamed. Although the P.T.O. cannot defend itself, its failed parts will tell a story.

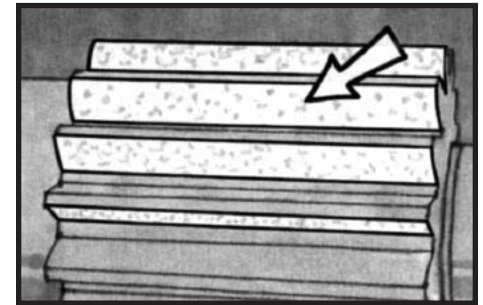

The first parts to inspect should be the gears. Check the surface of the gear teeth for signs of pitting . . . pitting is a normal wear pattern in most cases. However, contaminants in the oil or an installation that is too tight will cause severe pitting.

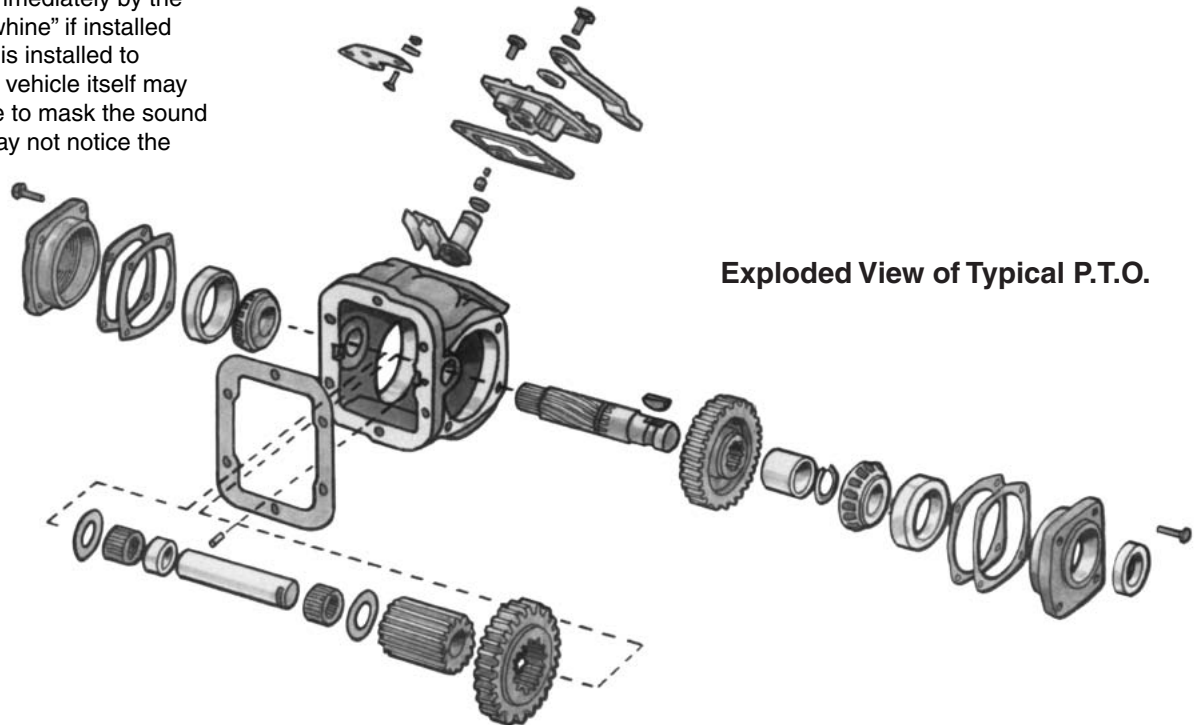

Exploded View of Typical P.T.O.

Troubleshooting

Once pitting of the gear surfaces has begun, there is nothing that can stop it. Severe pitting will eventually lead to gear tooth failure, therefore the damaged gear should be replaced when a P.T.O. is repaired or rebuilt.

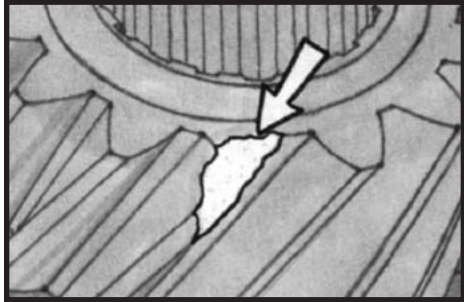

Sometimes a gear will chip a tooth because of mishandling or improper shifting. Even though a P.T.O. may continue to run with a chipped tooth, the damaged gear should be replaced immediately. It will damage the other teeth it comes in contact with during operation, not to mention the possible damage which could result from the loose chip. If the problem is allowed to continue, then failure to other parts in the P.T.O. or transmission could result.

Another possible problem during vehicle operation is "shock load." This occurs when the torque demands on a P.T.O. are suddenly greater than it was designed to take. "Shock load" could be caused by torque overloads, improper shifting, equipment failure, or excessive loads over a short period of time. If this happens, the P.T.O. is likely to fail immediately. The vehicle operator may not even be aware of the reason for the P.T.O. failure.

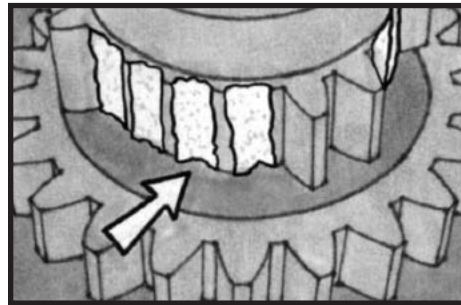

Worn gears can easily be affected by "shock load." If the worn gears are not replaced, they can eventually lead to broken gear teeth. This is the most severe form of P.T.O. failure. Worn or damaged gears are likely to break because of their reduced load carrying capacity. To prevent the possibility of broken gear teeth, always inspect auxiliary equipment for possible freeze-up. Also, recheck P.T.O. application, operating conditions and P.T.O. installation.

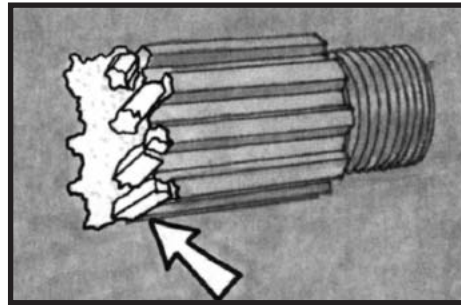

P.T.O. shafts are also vulnerable to operating abuse. If the shaft break is irregular, this usually indicates a torsional overload. Bending fatigue failure usually shows up as a smooth, flat break. To correct a P.T.O. shaft problem replace the failed shaft and check the speed and operating angle of the universal joint. Also, make sure the P.T.O. driveshaft is properly phased, (yokes in-line with each other). If a driveline is improperly installed it will cause vibration, which may lead to P.T.O. driveshaft or driven equipment problems.

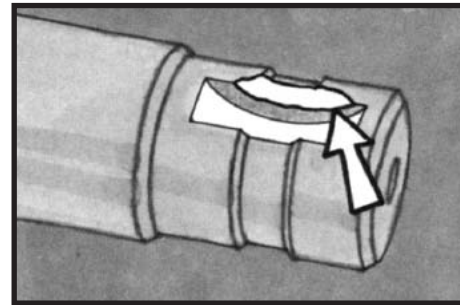

When inspecting a P.T.O. output shaft, always inspect the keyway. Sometimes a P.T.O. will fail because of a displaced keyway on the shaft caused by a loose fitting yoke or equipment freeze-up. Proper maintenance on auxiliary equipment and replacing a worn yoke and/or P.T.O. driven shaft will prevent this problem.

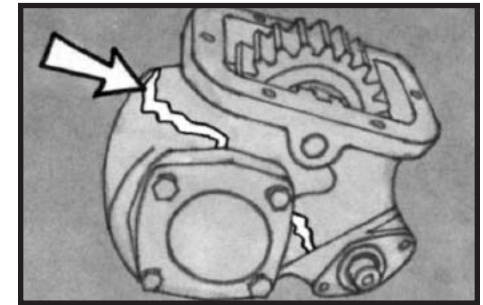

One of the most serious problems a P.T.O. can suffer is a cracked case. This condition can lead to oil loss and eventual transmission failure. Improper installation, poorly torqued bolts, or an unsupported direct mount pump can cause such a problem. A P.T.O. case can also be damaged by foreign objects meshing between the gear teeth, severe shock load, or even hitting an obstacle in the road.

Prevention is the best cure for P.T.O. case damage. Therefore, always torque the P.T.O. flange bolts in sequence and the proper specifications. Also, be sure to check the weight of the direct mount pump and, if it is over forty pounds, make a support bracket for it.

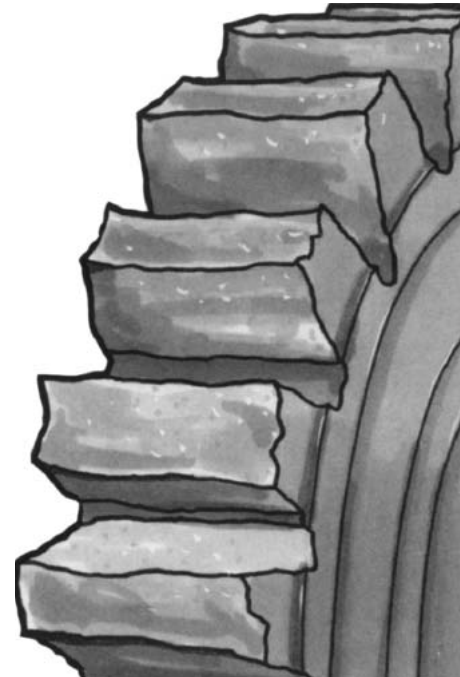

Deep Mesh Pattern Caused by Improper Backlash Adjustment

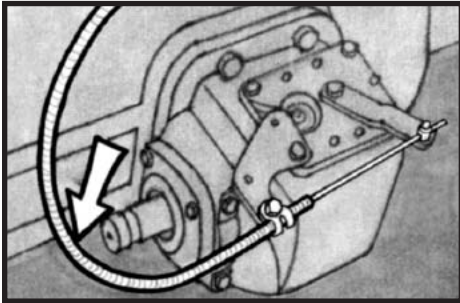

Shifting problems are sometimes a complaint an operator will have about his P.T.O. A P.T.O. that is hard to shift may be caused by a tight bend in the shifter cable, poor leverage, a gear that is installed backwards, or too tight of an installation. Many of these problems can be solved by inspecting the P.T.O. installation and making the proper adjustments regarding cable length, gear position, or shift lever.

Remember, a lever-operated shift linkage should not be connected to a wire shift cover. The mechanical advantage of the lever is often too great for the wire shift cover and could severely damage it. Also inversely, don't use a cable with a lever shift cover. The cable isn't capable of transmitting the force necessary to shift a lever mechanism.

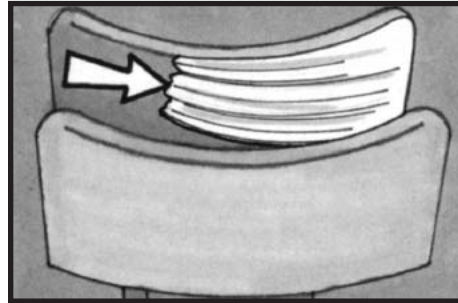

Most shifting complaints are caused by improper shifting procedure or incorrect linkage installation. Both of these situations will cause premature wear on the shift pad or fork and the shift rod or rail. To prevent this premature wear, avoid overshifting or undershifting the P.T.O. Overshifting causes the shifter fork to press against a P.T.O. gear during operation. This results in unnecessary friction and wear.

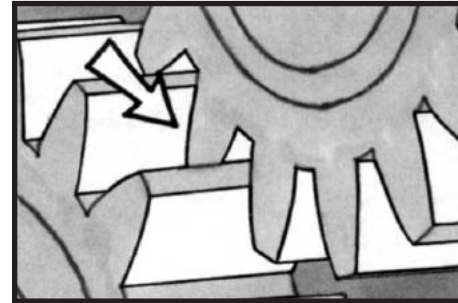

Undershifting allows incomplete gear tooth contact with the driver gear. This means only part of the tooth width is transmitting the torque and R.P.M. during P.T.O. operation. This situation can lead to gear failure or it could cause the P.T.O. to jump out of gear. These two problems can be overcome by checking linkage adjustments and proper operator training.

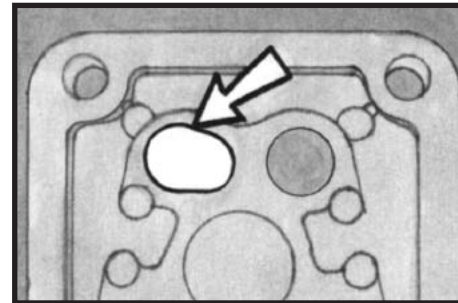

Shifting problems can also be caused by a worn or elongated shifter poppet hole. This causes the P.T.O. to jump out of gear and the parts in the shifter assembly to break or become loose. If this happens, replace those parts that are worn.

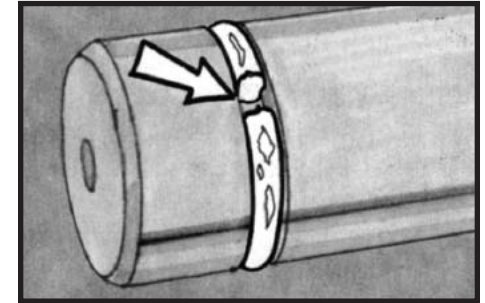

Seals and O-Rings may cause special problems in P.T.O. operations. Improper installation or heat build-up can cause O-Rings and seals to fail prematurely. Once seals or O-Rings fail, they should be replaced. The proper procedure for installing these parts is to lubricate them first so they will easily slide on the shaft.

Kits Bill of Materials

329644-1X	Kit Mounting & Installation ("XS")	
379556	Tee .438" - 20	1
3 AOE5-S	Elbow 90°	1
379964	Adapter Restriction .438" - 20 x .125" - 27	1
500841-1	Elbow .127" - 27 Pipe	1
380071	Capscrew SH Shoulder .375" - 16 x 3.375"	2
380075	Capscrew HH M12 x 1.750" x 2.170"	3
28-P-245X	O-Ring 5.017" x .103"	2
378431-13	Capscrew HH .375" - 16 x 1.375"	4
SK-461	Fitting Instructions	1
329644-2X	Kit Mounting & Installation ("AF")	
379556	Tee .438" - 20	1
3 AOE5-S	Elbow 90°	1
379964	Adapter Restriction .438" - 20 x .125" - 27	1
500841-1	Elbow .127" - 27 Pipe	1
380071	Capscrew SH Shoulder .375" - 16 x 3.375"	2
380075	Capscrew HH M12 x 1.750" x 2.170"	3
28-P-245X	O-Ring 5.017" x .103"	1
378431-13	Capscrew HH .375" - 16 x 1.375"	4
SK-461	Fitting Instructions	1
28-P-259X	O-Ring 3.984" x .139"	1
328948-36X	Kit Gasket & Installation	
328946X	Caution Label Kit	1
35-P-74	Gasket Shim	1
379085-2	Instructions Label	1
379624	Product Warranty Card	1
HY25-1892-M1/US	Owners Manual.....	1
HY25-1002-M1/US	Safety Guide	1
7170-86X	Kit Mounting / Stud Kit	
379451	Screw Pilot.....	2
379453-10	Capscrew M10 - 1.5" x 1.378"	8
379486	90° Elbow.....	1
SK-355	Installation	1

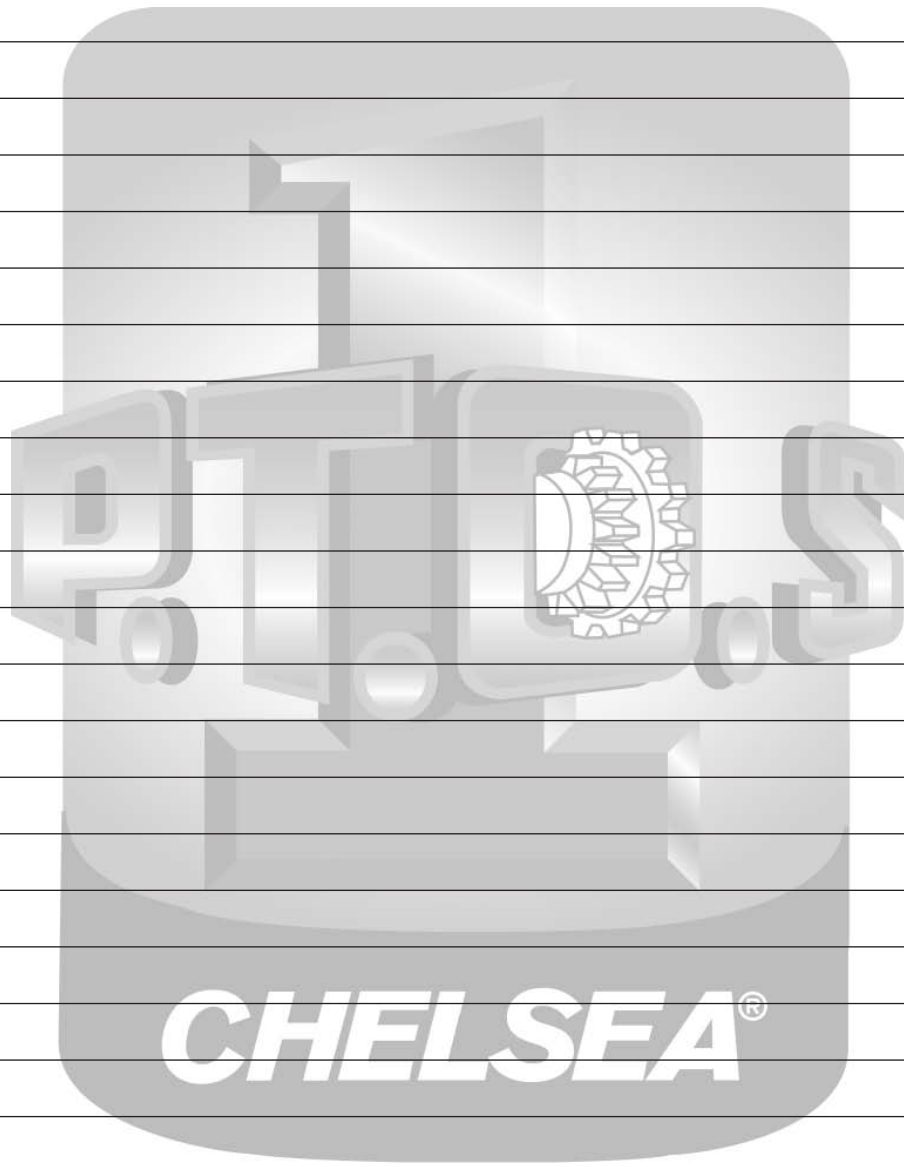

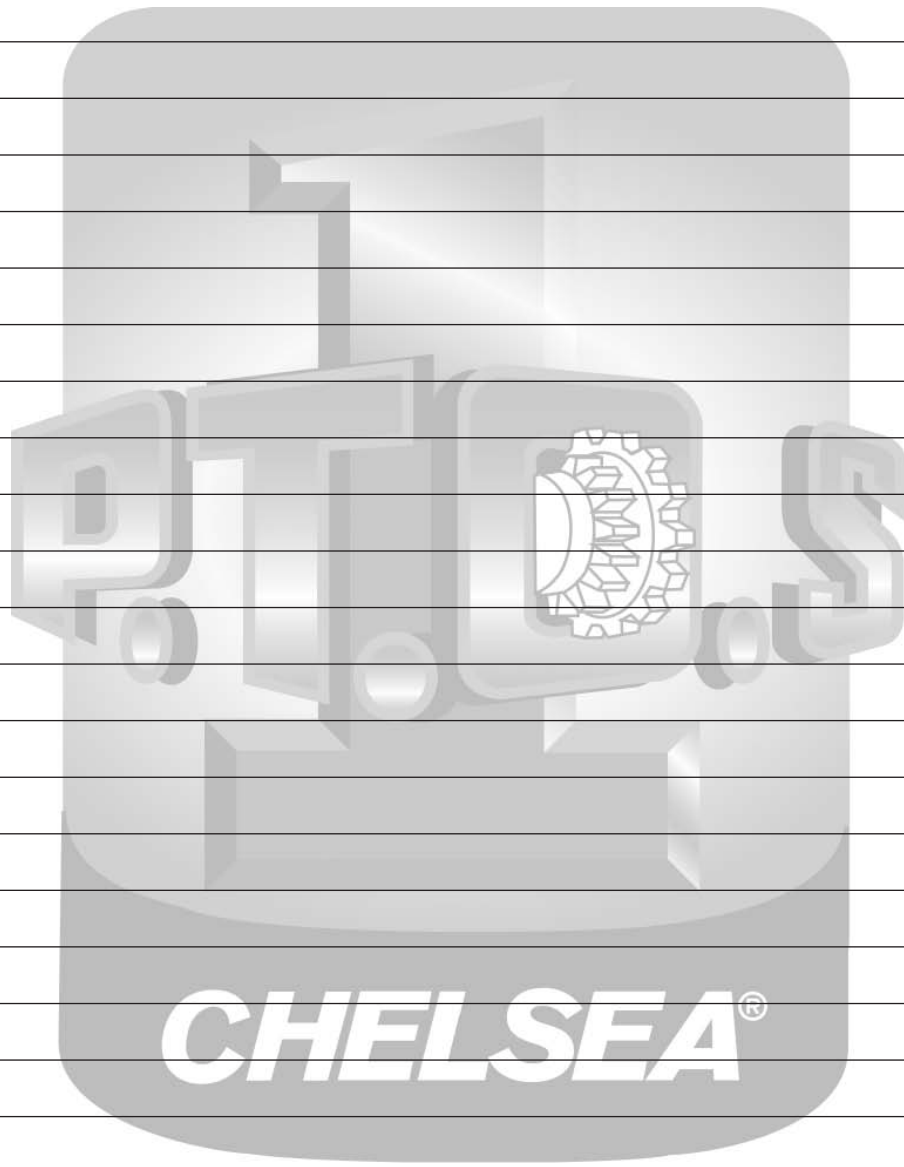

Offer of Sale

The items described in this document and other documents and descriptions provided by Parker Hannifin Corporation, its subsidiaries and its authorized distributors (“Seller”) are hereby offered for sale at prices to be established by Seller. This offer and its acceptance by any customer (“Buyer”) shall be governed by all of the following Terms and Conditions. Buyer’s order for any item described in its document, when communicated to Seller verbally, or in writing, shall constitute acceptance of this offer. All goods, services or work described will be referred to as “Products”.

1. Terms and Conditions. Seller’s willingness to offer Products, or accept an order for Products, to or from Buyer is subject to these Terms and Conditions or any newer version of the terms and conditions found on-line at www.parker.com/saleterms/. Seller objects to any contrary or additional terms or conditions of Buyer’s order or any other document issued by Buyer.

2. Price Adjustments; Payments. Prices stated on Seller’s quote or other documentation offered by Seller are valid for 30 days, and do not include any sales, use, or other taxes unless specifically stated. Unless otherwise specified by Seller, all prices are F.C.A. Seller’s facility (INCOTERMS 2010). Payment is subject to credit approval and is due 30 days from the date of invoice or such other term as required by Seller’s Credit Department, after which Buyer shall pay interest on any unpaid invoices at the rate of 1.5% per month or the maximum allowable rate under applicable law.

3. Delivery Dates; Title and Risk; Shipment. All delivery dates are approximate and Seller shall not be responsible for any damages resulting from any delay. Regardless of the manner of shipment, title to any products and risk of loss or damage shall pass to Buyer upon placement of the products with the shipment carrier at Seller’s facility. Unless otherwise stated, Seller may exercise its judgment in choosing the carrier and means of delivery. No deferment of shipment at Buyers’ request beyond the respective dates indicated will be made except on terms that will indemnify, defend and hold Seller harmless against all loss and additional expense. Buyer shall be responsible for any additional shipping charges incurred by Seller due to Buyer’s acts or omissions.

4. Warranty. Seller warrants that all products sold, other than the 590 Series, conform to the applicable Parker Chelsea standard specification for the lesser period of 2 years (24 Months) from date of service or 2-1/2 years (30 Months) from date of build (as marked on the product name plate). Seller warrants that the 590 Series will conform to the applicable Seller standard specification for the lesser period of 2 years (24 Months) from date of service or 2000 hours of usage. The prices charged for Seller’s products are based upon the exclusive limited warranty stated above, and upon the following disclaimer: **DISCLAIMER OF WARRANTY: THIS WARRANTY COMPRISES THE SOLE AND ENTIRE WARRANTY PERTAINING TO PRODUCTS PROVIDED HEREUNDER. SELLER DISCLAIMS ALL OTHER WARRANTIES, EXPRESS AND IMPLIED, INCLUDING DESIGN, MERCHANTABILITY AND FITNESS FOR A PARTICULAR PURPOSE.**

5. Claims; Commencement of Actions. Buyer shall promptly inspect all Products upon delivery. No claims for shortages will be allowed unless reported to the Seller within 10 days of delivery. No other claims against Seller will be allowed unless asserted in writing within 30 days after delivery. Buyer shall notify Seller of any alleged breach of warranty within 30 days after the date the defect is or should have been discovered by Buyer. Any action based upon breach of this agreement or upon any other claim arising out of this sale (other than an action by Seller for an amount due on any invoice) must be commenced within 12 months from the date of the breach without regard to the date breach is discovered.

6. LIMITATION OF LIABILITY. UPON NOTIFICATION, SELLER WILL, AT ITS OPTION, REPAIR OR REPLACE A DEFECTIVE PRODUCT, OR REFUND THE PURCHASE PRICE. IN NO EVENT SHALL SELLER BE LIABLE TO BUYER FOR ANY SPECIAL, INDIRECT, INCIDENTAL OR CONSEQUENTIAL DAMAGES ARISING OUT OF, OR AS THE RESULT OF, THE SALE, DELIVERY, NON-DELIVERY, SERVICING, USE OR LOSS OF USE OF THE PRODUCTS OR ANY PART THEREOF, OR FOR ANY CHARGES OR EXPENSES OF ANY NATURE INCURRED WITHOUT SELLER’S WRITTEN CONSENT, EVEN IF SELLER HAS BEEN NEGLIGENT, WHETHER IN CONTRACT, TORT OR OTHER LEGAL THEORY. IN NO EVENT SHALL SELLER’S LIABILITY UNDER ANY CLAIM MADE BY BUYER EXCEED THE PURCHASE PRICE OF THE PRODUCTS.

7. User Responsibility. The user, through its own analysis and testing, is solely responsible for making the final selection of the system and Product and assuring that all performance, endurance, maintenance, safety and warning requirements of the application are met. The user must analyze all aspects of the application and follow applicable industry standards and Product information. If Seller provides Product or system options, the user is responsible for determining that such data and specifications are suitable and sufficient for all applications and reasonably foreseeable uses of the Products or systems.

8. Loss to Buyer’s Property. Any designs, tools, patterns, materials, drawings, confidential information or equipment furnished by Buyer or any other items which become Buyer’s property, will be considered obsolete and may be destroyed by Seller after two consecutive years have elapsed without Buyer ordering the items manufactured using such property. Seller shall not be responsible for any loss or damage to such property while it is in Seller’s possession or control.

9. Special Tooling. A tooling charge may be imposed for any special tooling, including without limitation, dies, fixtures, molds and patterns, acquired to manufacture Products. Such special tooling shall be and remain Seller’s property notwithstanding payment of any charges by Buyer. In no event will Buyer acquire any interest in apparatus belonging to Seller which is utilized in the manufacture of the Products, even if such apparatus has been specially converted or adapted for such manufacture and notwithstanding any charges paid by Buyer. Unless otherwise agreed, Seller shall have the right to alter, discard or otherwise dispose of any special tooling or other property in its sole discretion at any time.

10. Buyer’s Obligation; Rights of Seller. To secure payment of all sums due or otherwise, Seller shall retain a security interest in the goods delivered and this agreement shall be deemed a Security Agreement under the Uniform Commercial Code. Buyer authorizes Seller as its attorney to execute and file on Buyer’s behalf all documents Seller deems necessary to perfect its security interest.

11. Improper use and Indemnity. Buyer shall indemnify, defend, and hold Seller harmless from any claim, liability, damages, lawsuits, and costs (including attorney fees), whether for personal injury, property damage, patent, trademark or copyright infringement or any other claim, brought by or incurred by Buyer, Buyer’s employees, or any other person, arising out of: (a) improper selection, improper application or other misuse of Products purchased by Buyer from Seller; (b) any act or omission, negligent or otherwise, of Buyer; (c) Seller’s use of patterns, plans, drawings, or specifications furnished by Buyer to manufacture Product; or (d) Buyer’s failure to comply with these terms and conditions. Seller shall not indemnify Buyer under any circumstance except as otherwise provided.

12. Cancellations and Changes. Orders shall not be subject to cancellation or change by Buyer for any reason, except with Seller’s written consent and upon terms that will indemnify, defend and hold Seller harmless against all direct, incidental and consequential loss or damage. Seller may change product features, specifications, designs and availability with notice to Buyer.

13. Limitation on Assignment. Buyer may not assign its rights or obligations under this agreement without the prior written consent of Seller.

14. Force Majeure. Seller does not assume the risk and shall not be liable for delay or failure to perform any of Seller’s obligations by reason of circumstances beyond the reasonable control of Seller (hereinafter “Events of Force Majeure”). Events of Force Majeure shall include without limitation: accidents, strikes or labor disputes, acts of any government or government agency, acts of nature, delays or failures in delivery from carriers or suppliers, shortages of materials, or any other cause beyond Seller’s reasonable control.

15. Waiver and Severability. Failure to enforce any provision of this agreement will not waive that provision nor will any such failure prejudice Seller’s right to enforce that provision in the future. Invalidation of any provision of this agreement by legislation or other rule of law shall not invalidate any other provision herein. The remaining provisions of this agreement will remain in full force and effect.

16. Termination. Seller may terminate this agreement for any reason and at any time by giving Buyer thirty (30) days written notice of termination. Seller may immediately terminate this agreement, in writing, if Buyer: (a) commits a breach of any provision of this agreement (b) appoints a trustee, receiver or custodian for all or any part of Buyer’s property (c) files a petition for relief in bankruptcy on its own behalf, or by a third party (d) makes an assignment for the benefit of creditors, or (e) dissolves or liquidates all or a majority of its assets.

17. Governing Law. This agreement and the sale and delivery of all Products hereunder shall be deemed to have taken place in and shall be governed and construed in accordance with the laws of the State of Ohio, as applicable to contracts executed and wholly performed therein and without regard to conflicts of laws principles. Buyer irrevocably agrees and consents to the exclusive jurisdiction and venue of the courts of Cuyahoga County, Ohio with respect to any dispute, controversy or claim arising out of or relating to this agreement.

18. Indemnity for Infringement of Intellectual Property Rights. Seller shall have no liability for infringement of any patents, trademarks, copyrights, trade dress, trade secrets or similar rights except as provided in this Section. Seller will defend and indemnify Buyer against allegations of infringement of U.S. patents, U.S. trademarks, copyrights, trade dress and trade secrets (“Intellectual Property Rights”). Seller will defend at its expense and will pay the cost of any settlement or damages awarded in an action brought against Buyer based on an allegation that a Product sold pursuant to this Agreement infringes the Intellectual Property Rights of a third party. Seller’s obligation to defend and indemnify Buyer is contingent on Buyer notifying Seller within ten (10) days after Buyer becomes aware of such allegations of infringement, and Seller having sole control over the defense of any allegations or actions including all negotiations for settlement or compromise. If a Product is subject to a claim that it infringes the Intellectual Property Rights of a third party, Seller may, at its sole expense and option, procure for Buyer the right to continue using the Product, replace or modify the Product so as to make it noninfringing, or offer to accept return of the Product and return the purchase price less a reasonable allowance for depreciation. Notwithstanding the foregoing, Seller shall have no liability for claims of infringement based on information provided by Buyer, or directed to Products delivered hereunder for which the designs are specified in whole or part by Buyer, or infringements resulting from the modification, combination or use in a system of any Product sold hereunder. The foregoing provisions of this Section shall constitute Seller’s sole and exclusive liability and Buyer’s sole and exclusive remedy for infringement of Intellectual Property Rights.

19. Entire Agreement. This agreement contains the entire agreement between the Buyer and Seller and constitutes the final, complete and exclusive expression of the terms of sale. All prior or contemporaneous written or oral agreements or negotiations with respect to the subject matter are herein merged.

20. Compliance with Law, U. K. Bribery Act and U.S. Foreign Corrupt Practices Act. Buyer agrees to comply with all applicable laws and regulations, including both those of the United Kingdom and the United States of America, and of the country or countries of the Territory in which Buyer may operate, including without limitation the U. K. Bribery Act, the U.S. Foreign Corrupt Practices Act (“FCPA”) and the U.S. Anti-Kickback Act (the “Anti-Kickback Act”), and agrees to indemnify and hold harmless Seller from the consequences of any violation of such provisions by Buyer, its employees or agents. Buyer acknowledges that they are familiar with the provisions of the U. K. Bribery Act, the FCPA and the Anti-Kickback Act, and certifies that Buyer will adhere to the requirements thereof. In particular, Buyer represents and agrees that Buyer shall not make any payment or give anything of value, directly or indirectly to any governmental official, any foreign political party or official thereof, any candidate for foreign political office, or any commercial entity or person, for the purpose of influencing such person to purchase products or otherwise benefit the business of Seller.

07/14

Parker Worldwide

Europe, Middle East, Africa

AE – United Arab Emirates,
Dubai

Tel: +971 4 8127100
parker.me@parker.com

AT – Austria, Wiener Neustadt

Tel: +43 (0)2622 23501-0
parker.austria@parker.com

AT – Eastern Europe, Wiener
Neustadt

Tel: +43 (0)2622 23501 900
parker.easteurope@parker.com

AZ – Azerbaijan, Baku

Tel: +994 50 22 33 458
parker.azerbaijan@parker.com

BE/LU – Belgium, Nivelles

Tel: +32 (0)67 280 900
parker.belgium@parker.com

BG – Bulgaria, Sofia

Tel: +359 2 980 1344
parker.bulgaria@parker.com

BY – Belarus, Minsk

Tel: +375 17 209 9399
parker.belarus@parker.com

CH – Switzerland, Etoy

Tel: +41 (0)21 821 87 00
parker.switzerland@parker.com

CZ – Czech Republic, Klecany

Tel: +420 284 083 111
parker.czechrepublic@parker.com

DE – Germany, Kaarst

Tel: +49 (0)2131 4016 0
parker.germany@parker.com

DK – Denmark, Ballerup

Tel: +45 43 56 04 00
parker.denmark@parker.com

ES – Spain, Madrid

Tel: +34 902 330 001
parker.spain@parker.com

FI – Finland, Vantaa

Tel: +358 (0)20 753 2500
parker.finland@parker.com

FR – France, Contamine s/Arve

Tel: +33 (0)4 50 25 80 25
parker.france@parker.com

GR – Greece, Athens

Tel: +30 210 933 6450
parker.greece@parker.com

HU – Hungary, Budaoers

Tel: +36 23 885 470
parker.hungary@parker.com

IE – Ireland, Dublin

Tel: +353 (0)1 466 6370
parker.ireland@parker.com

IT – Italy, Corisico (MI)

Tel: +39 02 45 19 21
parker.italy@parker.com

KZ – Kazakhstan, Almaty

Tel: +7 7273 561 000
parker.easteurope@parker.com

NL – The Netherlands, Oldenzaal

Tel: +31 (0)541 585 000
parker.nl@parker.com

NO – Norway, Asker

Tel: +47 66 75 34 00
parker.norway@parker.com

PL – Poland, Warsaw

Tel: +48 (0)22 573 24 00
parker.poland@parker.com

PT – Portugal, Leca de Palmeira

Tel: +351 22 999 7360
parker.portugal@parker.com

RO – Romania, Bucharest

Tel: +40 21 252 1382
parker.romania@parker.com

RU – Russia, Moscow

Tel: +7 495 645-2156
parker.russia@parker.com

SE – Sweden, Spånga

Tel: +46 (0)8 59 79 50 00
parker.sweden@parker.com

SK – Slovakia, Banská Bystrica

Tel: +421 484 162 252
parker.slovakia@parker.com

SL – Slovenia, Novo Mesto

Tel: +386 7 337 6650
parker.slovenia@parker.com

TR – Turkey, Istanbul

Tel: +90 216 4997081
parker.turkey@parker.com

UA – Ukraine, Kiev

Tel: +380 44 494 2731
parker.ukraine@parker.com

UK – United Kingdom, Warwick

Tel: +44 (0)1926 317 878
parker.uk@parker.com

ZA – South Africa, Kempton Park

Tel: +27 (0)11 961 0700
parker.southafrica@parker.com

North America

CA – Canada, Milton, Ontario

Tel: +1 905 693 3000

MX – Mexico, Toluca

Tel: +52 72 2275 4200

Asia Pacific

AU – Australia, Castle Hill

Tel: +61 (0)2-9634 7777

CN – China, Shanghai

Tel: +86 21 2899 5000

HK – Hong Kong

Tel: +852 2428 8008

IN – India, Mumbai

Tel: +91 22 6513 7081-85

JP – Japan, Fujisawa

Tel: +81 (0)4 6635 3050

KR – South Korea, Seoul

Tel: +82 2 559 0400

MY – Malaysia, Shah Alam

Tel: +60 3 7849 0800

NZ – New Zealand, Mt Wellington

Tel: +64 9 574 1744

SG – Singapore

Tel: +65 6887 6300

TH – Thailand, Bangkok

Tel: +662 717 8140

TW – Taiwan, New Taipei City

Tel: +886 2 2298 8987

South America

AR – Argentina, Buenos Aires

Tel: +54 3327 44 4129

BR – Brazil, Cachoeirinha RS

Tel: +55 51 3470 9144

CL – Chile, Santiago

Tel: +56 2 623 1216

Pan Am, Miami

Tel: +1 305-470-8800

