



---

# SERVICE/SPARE PARTS SERIES F11

Effective: November, 2024

Supersedes: March, 2023

## Basic formulas for hydraulic motors

Flow (q)

$$q = \frac{D \times n}{1000 \times \eta_v} \text{ [l/min]}$$

Torque (M)

$$M = \frac{D \times \Delta p \times \eta_{hm}}{63} \text{ [Nm]}$$

Power (P)

$$P = \frac{q \times \Delta p \times \eta_t}{600} \text{ [kW]}$$

D - displacement [cm<sup>3</sup>/rev]

n - shaft speed [rpm]

$\eta_v$  - volumetric efficiency

$\Delta p$  - differential pressure [bar]  
(between inlet and outlet)

$\eta_{hm}$  - mechanical efficiency

$\eta_t$  - overall efficiency  
( $\eta_t = \eta_v \times \eta_{hm}$ )

## Basic formulas for hydraulic pumps

Flow (q)

$$q = \frac{D \times n \times \eta_v}{1000} \text{ [l/min]}$$

Torque (M)

$$M = \frac{D \times \Delta p}{63 \times \eta_{hm}} \text{ [Nm]}$$

Power (P)

$$P = \frac{q \times \Delta p}{600 \times \eta_t} \text{ [kW]}$$

D - displacement [cm<sup>3</sup>/rev]

n - shaft speed [rpm]

$\eta_v$  - volumetric efficiency

$\Delta p$  - differential pressure [bar]  
(between inlet and outlet)

$\eta_{hm}$  - mechanical efficiency

$\eta_t$  - overall efficiency  
( $\eta_t = \eta_v \times \eta_{hm}$ )

## Conversion factors

1 kg	2.20 lb
1 N	0.225 lbf
1 Nm	0.738 lbf ft
1 bar	14.5 psi
1 l	0.264 US gallon
1 cm <sup>3</sup>	0.061 cu in
1 mm	0.039 in
1°C	$\frac{5}{9}(\text{°F}-32)$
1 kW	1.34 hp

## Conversion factors

1 lb	0.454 kg
1 lbf	4.448 N
1 lbf ft	1.356 Nm
1 psi	0.068948 bar
1 US gallon	3.785 l
1 cu in	16.387 cm <sup>3</sup>
1 in	25.4 mm
1°F	$\frac{9}{5}\text{°C} + 32$
1 hp	0.7457 kW

## Table of Contents

General Information .....	4
Cross section.....	4
Specifications .....	5
Preparation.....	6
Tools required.....	6
Disassemble F11 .....	7 – 10
Assembly F11.....	11 – 16
Torque .....	17
Barrel retaining ring.....	18 – 20
Test procedur.....	21
Cavitation .....	22 – 25
Split view F11.....	26
Part specification F11 .....	27
F11 spare part list.....	28 – 34
How to select spare part guide .....	35 – 39

## General information

F11 is bent axis, fixed displacement heavy-duty motor/pump series. They can be used in numerous applications in both open and closed loop circuits.

Series F11 are available in ISO, CETOP, SAW and SAE versions.

The F11 series are available in sizes 5, 6, 8, 10, 12, 14 and 19 cc.

Thanks to the unique spherical piston design, F11 motors can be used at unusually high shaft speeds. Operating pressures to 420 bar provides for the high output power capability.

The 40° angle between shaft and cylinder barrel allows for a very compact, lightweight motor/pump.

The laminated piston ring offers important advantages such as low internal leakage and thermal shock resistance.

The pump version has highly engineered valve plates for increased selfpriming speed

and low noise, available with left and right hand rotation.

The F11 motors produce very high torque at start-up as well as at low speeds.

Our unique timing gear design synchronizes shaft and cylinder barrel, making the F11 very tolerant to high 'G' forces and torsional vibrations. Heavy duty roller bearings permit substantial external axial and radial shaft loads.

The F11's have a simple and straightforward design with very few moving parts, making them very reliable motors/pumps.

The unique piston locking, timing gear and bearing set-up as well as the limited number of parts add up to a very robust design with long service life and, above all, proven reliability.

## F11 cross section

1. Piston
2. Shaft
3. Cylinder barrel
4. Valve plate
5. Ring gear
6. Tapered roller bearing
7. Shaft seal

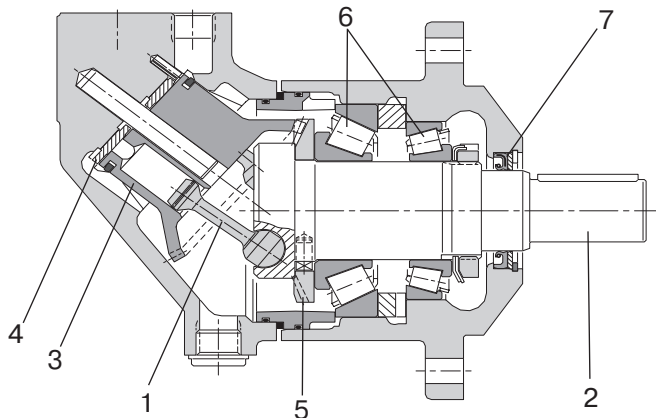

## Specifications

Frame size F11	-005	-006	-008	-010	-012	-014	-019
<b>Displacement</b> [cm <sup>3</sup> /rev]	4.9	6.0	8.0	9.8	12.5	14.3	19.0
<b>Operating pressure</b> [bar]							
max intermittent <sup>1)</sup>	420	420	420	420	420	420	420
max continuous	350	350	350	350	350	350	320
<b>Motor operating speed</b> [rpm]							
max intermittent <sup>1)</sup>	14000	11200	11200	11200	10300	9900	8900
max continuous	12800	10200	10200	10200	9400	9000	8100
min continuous	50	50	50	50	50	50	50
<b>Max pump selfpriming speed</b>	4600	-	4200	4200	3900	3900	3500
<b>Motor input flow</b>							
max intermittent <sup>1)</sup>	69	67	90	110	129	142	169
max continuous	63	61	82	100	118	129	154
<b>Drain temperature, max</b> [°C]	115	115	115	115	115	115	115
min [°C]	-40	-40	-40	-40	-40	-40	-40
<b>Theoretical torque at 100 bar</b> [Nm]	7.8	9.5	9.5	15.6	19.8	22.7	30.2
<b>Mass moment of inertia</b>							
(x10 <sup>-3</sup> ) [kg m <sup>2</sup> ]	0.16	0.39	0.39	0.39	0.40	0.42	1.1
<b>Weight</b> [kg]	4.7	6.5	6.5	6.5	7.5	7.5	11

<sup>1)</sup> Intermittent: max 6 seconds in any one minute.

## Preparation

### Before disassembling motor:

- Always keep work space clean
- Always use correct tools
- Make documentation and take photos if required
- Only use standard spare parts from Parker

## Tools required

- Retaining ring tool, internal and external
- Hex key
- Screw driver
- Plier
- Plastic hammer
- Mandrel
- Hook tool
- Torque wrench
- Brush
- Hydraulic press



## Disassemble F11



1. Remove the key with a plier.



2. Untighten the screws.



3. Disassemble the retaining ring.



4. Remove the back up ring.

## Disassemble F11



5. Remove the shaft seal carefully with screw driver and hammer.



6. Remove the bearing housing by tapping carefully underneath with hammer.



7. Carefully remove the shaft package from housing.



8. Remove all pistons.



## Disassemble F11

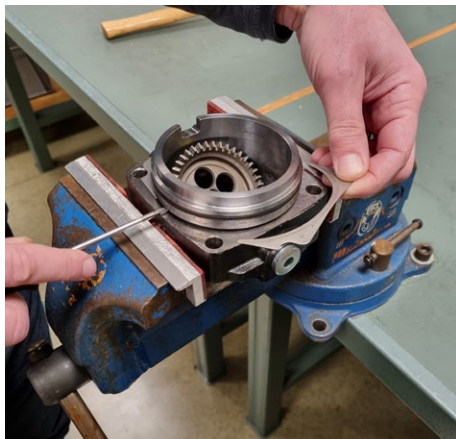

9. Remove shims and guide spacer. Screw driver can be used carefully.



10. Remove the O-rings from the guide spacer.



11. Remove the cylinder barrel by holding the housing as shown on picture and gently tap to work bench.



12. Remove the valve plate with a hook tool or retaining ring tool carefully.

## Disassemble F11

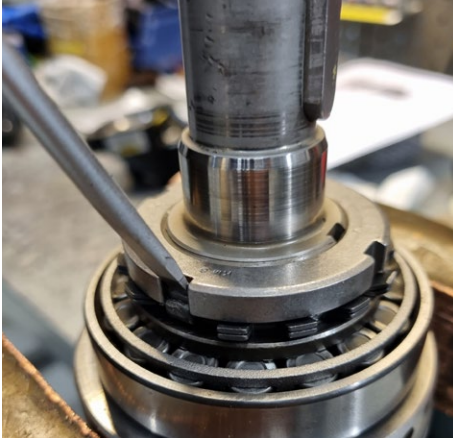

13. Tap the locker ring.



14. Untighten the round nut and remove locker rings.



15. Place the shaft package on a tube so it's standing on the ring gear. Press the shaft off the bearings. Use some soft material when the shaft fall out.

## Assemble F11



1. Place the ring gear on the shaft with the guide pin located against the guide hole.

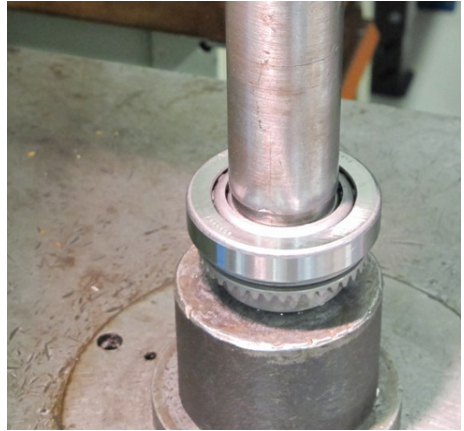

2. Press down the large tapered roller bearing together with the ring gear.



3. Place the distance ring on the large tapered roller bearing.



4. Place the small tapered roller bearing on the shaft as on the picture.

## Assemble F11



5. Press down the small tapered roller bearing in small steps until correct preload is achieved. Not too tight and no backlash.



6. Place the lock washers on the shaft.



7. Assemble the round nut and tighten it until one opening is in correct position for the lock washer.



8. Secure the round nut as shown in the picture.

## Assemble F11



9. Assemble the valve plate. Make sure the slot is in correct position and the valve plate is located as shown in picture.

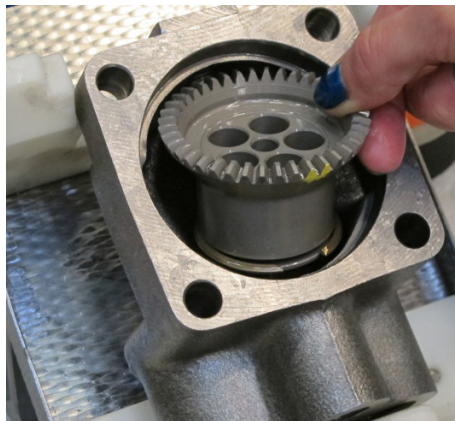

10. Assemble the cylinder barrel. Instructions on page 18.



11. Assemble the O-rings on the distance ring.



12. Carefully tap down the guide spacer to the barrel housing. Lubricate with oil before assembly. The slot on the guide spacer must be located towards the main ports.

## Assemble F11



13. Assemble the shims. Some products comes without shims, see spare part list for more information.



14. Lubricate the ball sockets before assembly. Assemble the pistons.

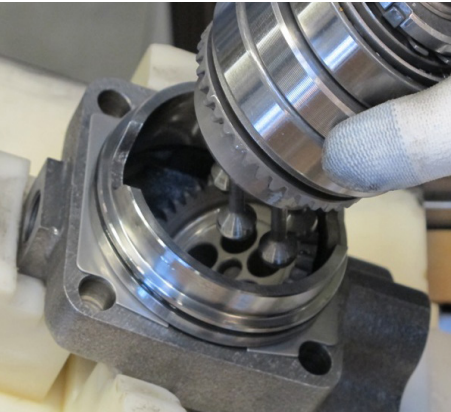

15. Assemble the shaft package with pistons in to the cylinder barrel.

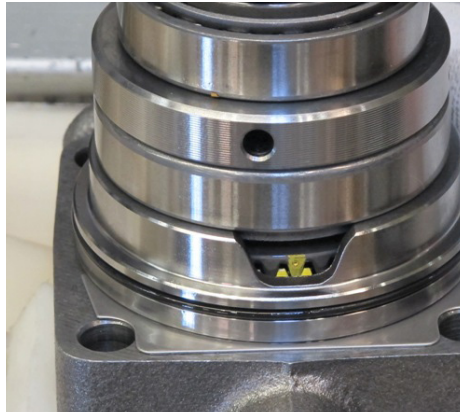

16. Make sure the timing is correct.

## Assemble F11

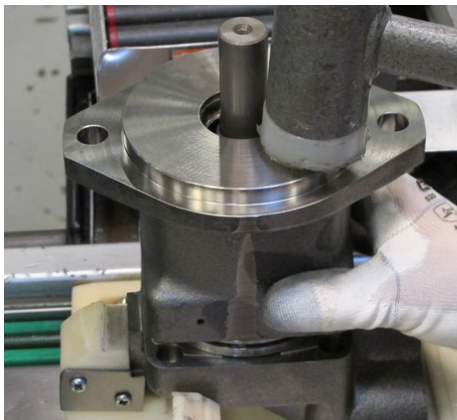

17. Carefully tap down the bearing housing.

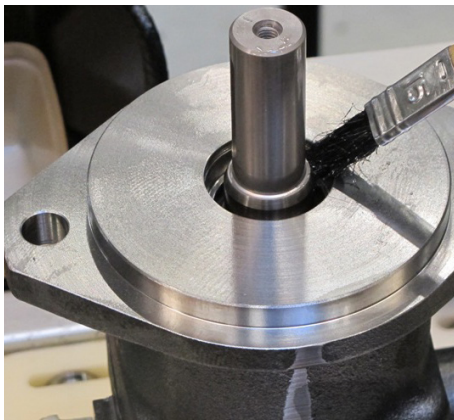

18. Lubricate the sealing surface on the shaft before assembling the shaft seal.

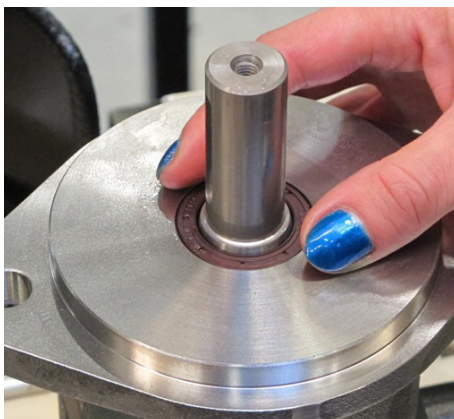

19. Carefully push down the shaft seal. Important to assemble in right position.



20. Place the back up ring with the radius against the dust lip on the shaft seal.

## Assemble F11



21. Carefully tap down shaft seal and support ring.

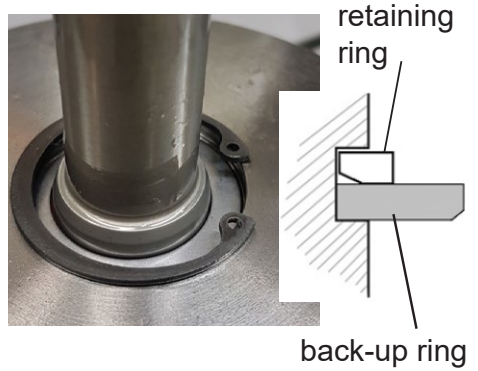

22. Assemble the retaining ring. Make sure the chamfer is downwards.

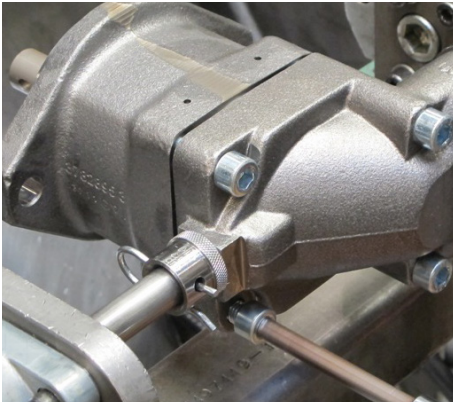

23. Assemble the hex. screws and torque them to specified value, shown on page 17.

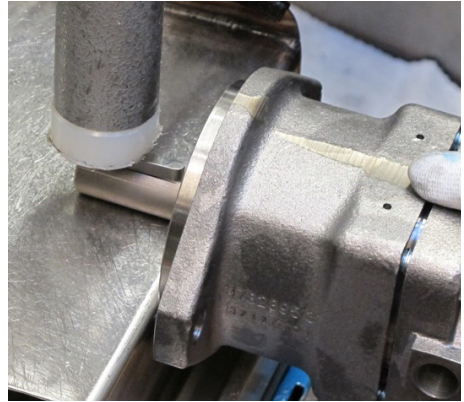

24. Tap down the flat key and turn the shaft at least one rev. Make sure the back-lash of the gears are correct (see page 17).



## Torque

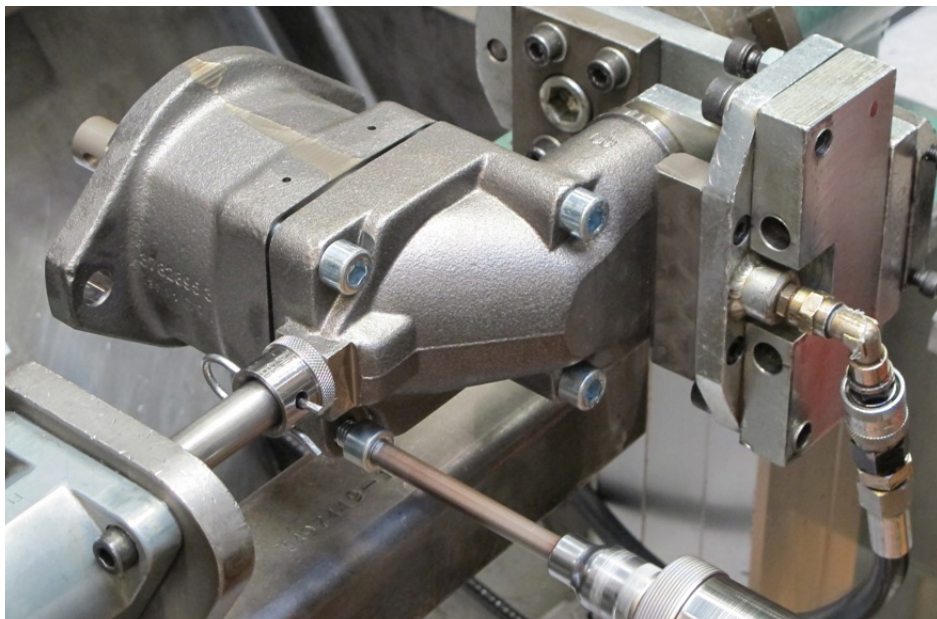

Size	Torque (Nm)	Torque (lb*ft)
F11-5	24±4	18±3
F11-6	48±8	35±6
F11-8	48±8	35±6
F11-10	48±8	35±6
F11-12	48±8	35±6
F11-14	48±8	35±6
F11-19	48±8	35±6

### Gear Backlash

0.10 - 0.25 mm

Size	"R" mm
F11-5	25.0
F11-6	31.3
F11-8	31.3
F11-10	31.3
F11-12	31.3
F11-14	31.3
F11-19	37.5

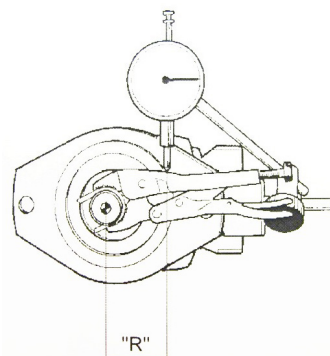

## Barrel retaining ring

1. Assemble the barrel retaining ring.  
Note, grooves upwards as on picture.



One groove

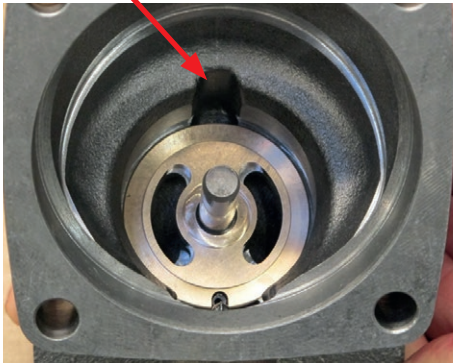

2. When the barrel housing have one groove assemble the cylinder barrel as shown in picture 3.

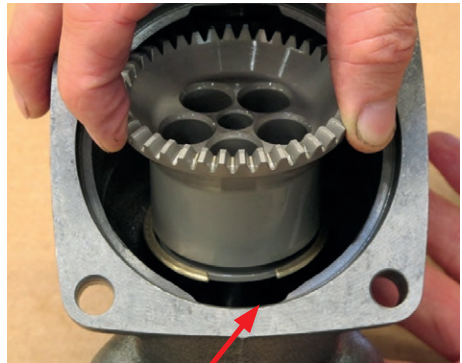

Opening barrel retaining ring

3. Assemble the cylinder barrel as shown in picture.

Two grooves

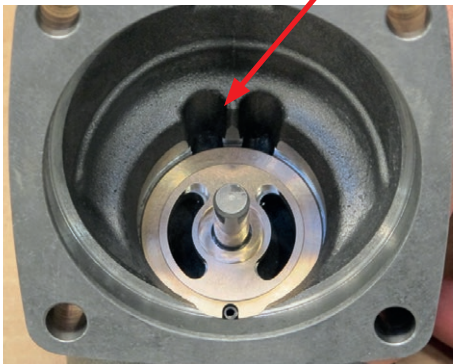

4. When the barrel housing have two grooves assemble the cylinder barrel as shown in picture 5.



Opening barrel retaining ring

5. Assemble the cylinder barrel as shown in picture.

## Valve plates F11

Type	Description
M	Bi-directional, motor or pump operation
S	Bi-directional, motor operation, high speed, bi-metal
L	Left hand rotation, pump operation
R	Right hand rotation, pump operation
Q	Bi-directional, motor operation, low noise
H	Bi-directional, motor operation, high pressure
J	Right hand rotation, motor operation, internal drain
G	Left hand rotation, motor operation, internal drain

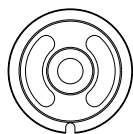

**M**

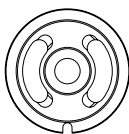

**Q**



**R**

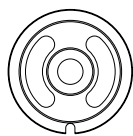

**S**

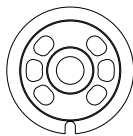

**H**



**L**



**J**

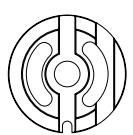

**G**

### Note!

The internal drained valve plates G and J is shown from the back side of the valve plate.

From the front, when installed, they look the same as the M valve plate.

## Motors with anti-cavitation valve

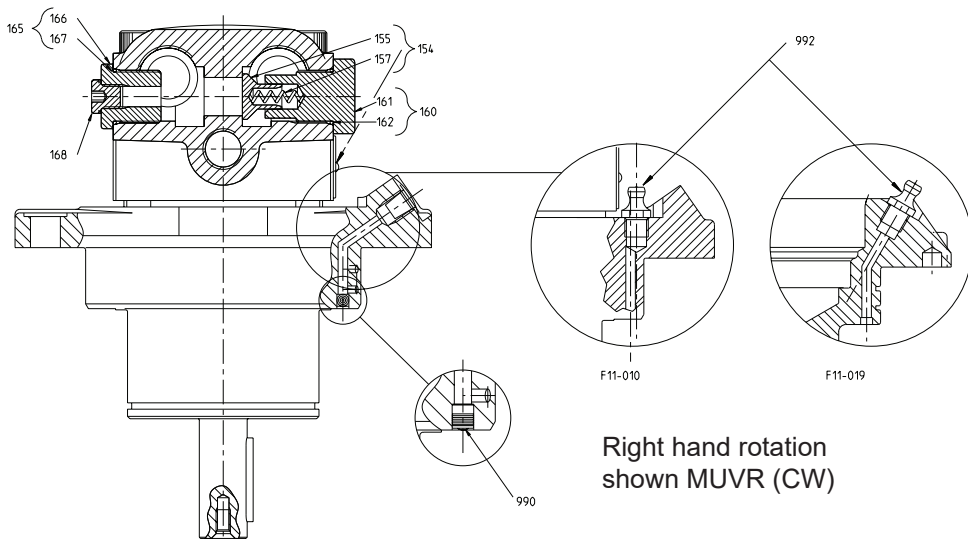

### How to change direction of rotation

In this example from F11-019-MB-CV-K-000-**MUVR**-P0 (CW) to F11-019-MB-CV-K-000-**MUVR**-P0 (CCW):

Hold motor with shaft pointing to you and port pointing upward. Move item 160, 155 and 157 from right to left side and item 165 and 168 from left to right side rotation.

### Parts Specification p/n 3724429

Item	Title
155	Check Valve Cone
157	Compression Spring
160	Hex Socket Plug assy
165	Adapter Nipple assy
168	Hexagon Plug assy

### Torque

Item	Torque (Nm)	Torque (lbf*ft)
160	100±10	74±7
165	100±10	74±7
168	25±5	18±4

## Test Procedure

The general condition of the unit can be established by checking the drain flow. Remove the drain line and keep the drain port above a suitable container. Run the unit at 1000 rpm and pressurise the system to 200 bar (3000 psi)

Measure the drain flow for one minute; if it

exceeds the maximum figures shown below, the unit is worn or damaged internally and should be replaced or repaired. Also, check for leakage at the shaft seal and between the bearing and barrel housings.

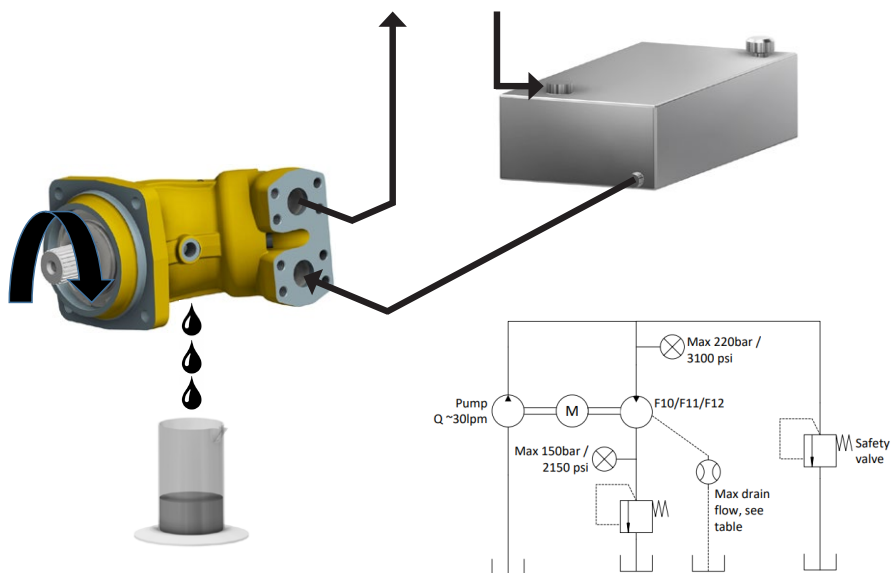

Series	Normal (gpm, US)	Normal (l/min)	Max (gpm, US)	Max (l/min)
F11-5	0.08	0.3	0.12	0.4
F11-6	0.08	0.3	0.13	0.5
F11-8	0.10	0.4	0.17	0.6
F11-10	0.13	0.5	0.21	0.8
F11-12	0.15	0.6	0.26	1.0
F11-14	0.17	0.6	0.26	1.0
F11-19	0.20	0.8	0.35	1.3

## Cavitation

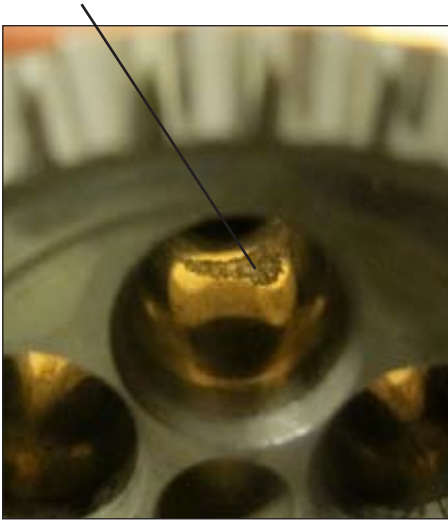

Cavitation marks in the cylinder barrel bores, on the port side or on the valve plate depends on air in the oil.

Reasons can be when inlet pressure/flow isn't sufficient. Example when stopping a fan drive and inertia will run the motor.



### Why cavitation?

- Too high speed
- Too low inlet pressure (pump mode)

### What consequence?

- A metallic sound comes from the system
- Material damage as craters in the goods which contaminate the hydraulic system
- Lift off if severe cavitation
- Shaft seal leakage

## Cavitation



Valve plate with scratched surface.

The damage depends on contaminated oil due to poor filtration, clogged filter, previous break down or bad handling when filling the reservoir.



Cylinder barrel with severe damaged surface at the porting. The damage depends on contaminated oil due to poor filtration, clogged filter, previous break down or bad handling when filling the reservoir.



Pistons with worn out piston rings, some of them are missing and the spher is very damaged.

This depends on contaminated oil and/or overspeed/cavitation.

## Cavitation



Pistons with the grinding rings intact have been in a clean system. No overspeed and good viscosity on the oil.



Pistons with worn piston ball. The ball is polished due to contaminated oil and/or overspeed.

**Note!**

High temperature (low viscosity) can be a reason.



## Cavitation

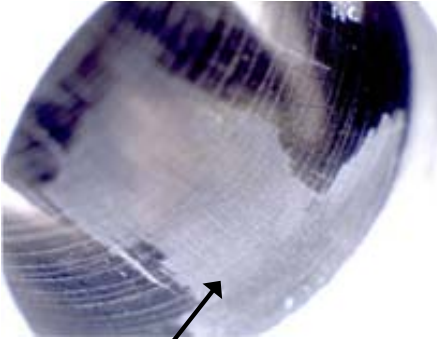

Severe damage in cylinder bore at the piston's turning point.

Reason is too high speed, the piston is thrown out in the periphery and breaks through the protecting oil film.

High speed wear

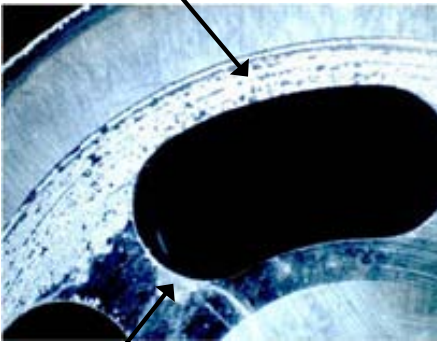

High speed wear at the outer periphery on the cylinder barrel. The protecting oil film can't withstand the high speed.

There are also cavitation marks on the cylinder barrel.

Cavitation

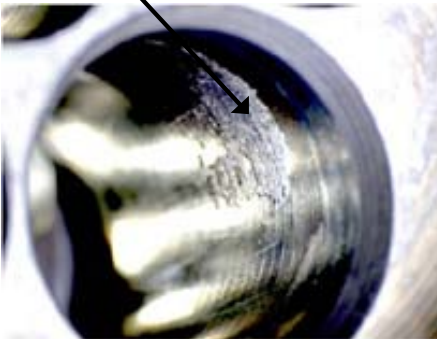

From the same cylinder barrel there are severe cavitation marks in the cylinder bores due to high speed.

# Split view F11

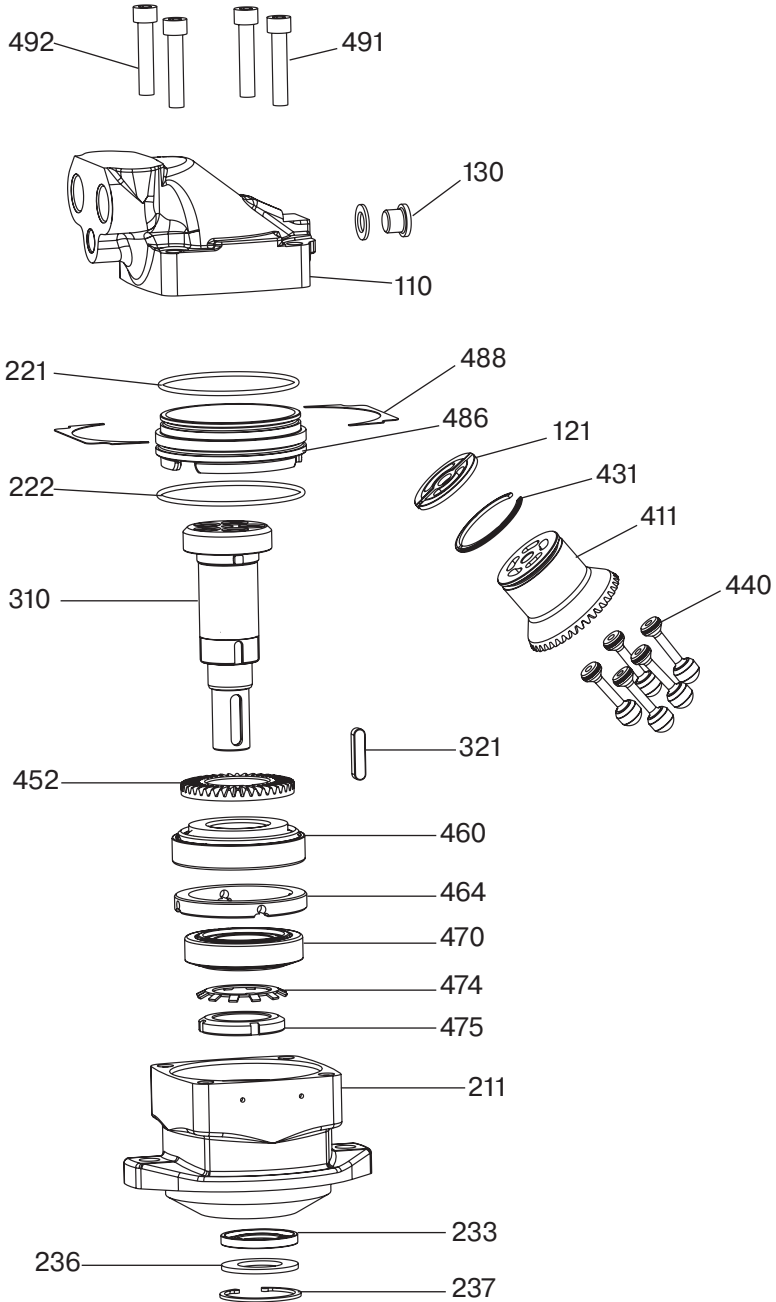

## Parts specification

<b>Item</b>	<b>Description</b>
110	Barrel housing
121	Valve Plate (repair kit)
130	Hex Socket Plug Assy
211	Bearing Housing
221	O-Ring (seal kit)
222	O-Ring (seal kit)
233	Shaft Seal (seal kit)
236	Back-up ring (seal kit)
237	Retaining Ring (seal kit)
310	Shaft
321	Key (key kit)
411	Cylinder Barrel Assy (repair kit)
431	Barrel Retaining ring (repair kit)
440	Piston Assy (repair kit)
452	Ring Gear
460	Tap Roller Bearing (bearing kit)
464	Spacer ring (bearing kit)
470	Tap Roller Bearing (bearing kit)
474	Lock washer ( bearing kit)
475	Round nut (bearing kit)
486	Guide spacer
488	Shims (shim kit)
491	Hex Screw (repair kit)
492	Hex Screw (repair kit)

Pos	Part No	Description	Qty	Remarks
<b>Housing parts</b>				
110	3703007	Barrel Housing Assy Type B	1	Require item 130
130		Hex Socket Plug Assy BSP	1	VST11/4EDVITCF
211	3700520	Bearing Housing Type C	1	
486	3797258	Guide Spacer	1	
<b>Rotating parts</b>				
310	3796077	Shaft Assy type K	1	Require item 321
321	3724442*	Flat Key type K	1	
452	3795831	Ring Gear	1	

**For other parts please contact Parker Hannifin**

<b>Seal kits</b>	
3797118	Sealing kit type V FPM
3797109	Sealing kit type N NBR
<b>Repair Spare part Kit</b>	
3721300	Type M (Motor)
3723953	Type H (High pressure Motor)
3723954	Type L (CCW pump)
3723955	Type R (CW pump)
<b>Bearing spare part kit</b>	
3723967	Bearing kit
<b>Shim kit</b>	
3721345	Shims kit 0,8 mm

**Seal kit contain:**  
 O-rings pos: 221, 222  
 Shaft seal pos: 233  
 Back-up Ring pos: 236  
 Retaining rings pos: 237

**Repair spare part kit contain:**  
 Valve plate pos: 121  
 Cylinder Barrel pos: 411  
 Barrel Retaining Ring pos: 431  
 Pistons pos: 440 (5 pcs)  
 Hex Screws pos: 491, 492 (4 pcs)

**Bearing spare part kit contain:**  
 Tap Rol Bearing pos: 460, 470  
 Lock washer pos: 474  
 Round nut pos: 475

\*Kit contain 100 pcs

**Shim kit contain:**  
 Shims pos: 488 (1 pcs on each side)

## F11-6

Pos	Part No	Description	Qty	Remarks
<b>Housing parts</b>				
110	3784801	Barrel Housing Assy Type B	1	Require item 130
130		Hex Socket Plug Assy BSP	1	VSTI3/8EDVITCF
211	3700905	Bearing Housing Type C	1	
486	3723141**	Guide Spacer	1	
<b>Rotating parts</b>				
310	3796083	Shaft Assy type D	1	
310	3796080	Shaft Assy type K	1	Require item 321
310	3785221	Shaft Assy type S	1	
321	3724441*	Flat Key type K	1	
452	3795832	Ring Gear	1	

For other parts please contact Parker Hannifin

**Seal kits**  
3783269 Sealing kit type V FPM

**Repair Spare part Kit**  
3723956 Type M (Motor)

**Bearing spare part kit**  
3723968 Bearing kit

**Shim kit**  
3721346 Shims kit 0,8 mm

**Seal kit contain:**  
O-rings pos: 221, 222  
Shaft seal pos: 233  
Back-up Ring pos: 236  
Retaining rings pos: 237

**Repair spare part kit contain:**  
Valve plate pos: 121  
Cylinder Barrel pos: 411  
Barrel Retaining Ring pos: 431  
Pistons pos: 440 (5 pcs)  
Hex Screws pos: 491, 492 (4 pcs)

**Bearing spare part kit contain:**  
Tap Rol Bearing pos: 460, 470  
Lock washer pos: 474  
Round nut pos: 475

\*Kit contain 100 pcs

\*\* New design of guide spacer from  
2023-04-01, Require no shims

**Shim kit contain:**  
Shims pos: 488 (1 pcs on each side)

Pos	Part No	Description	Qty	Remarks
<b>Housing parts</b>				
110	3784801	Barrel Housing Assy Type B	1	Require item 130
130		Hex Socket Plug Assy BSP	1	VSTI3/8EDVITCF
211	3700905	Bearing Housing Type C	1	
486	3723141**	Guide Spacer	1	
<b>Rotating parts</b>				
310	3796083	Shaft Assy type D	1	
310	3796080	Shaft Assy type K	1	Require item 321
310	3785221	Shaft Assy type S	1	
321	3724441*	Flat Key type K	1	
452	3795832	Ring Gear	1	

**For other parts please contact Parker Hannifin**

#### Seal kits

3783269	Sealing kit type V FPM
3797111	Sealing kit type N NBR
3783383	Sealing kit type S PTFE

#### Repair Spare part Kit

3725278	Type Q (Low noise motor)
3725279	Type S (High speed Motor)
3725280	Type L (CCW pump)
3725281	Type R (CW pump)

#### Bearing spare part kit

3723968	Bearing kit
---------	-------------

#### Shim kit

3721346	Shims kit 0,8 mm
---------	------------------

#### Seal kit contain:

O-rings pos: 221, 222  
 Shaft seal pos: 233  
 Back-up Ring pos: 236  
 Retaining rings pos: 237

#### Repair spare part kit contain:

Valve plate pos: 121  
 Cylinder Barrel pos: 411  
 Barrel Retaining Ring pos: 431  
 Pistons pos: 440 (5 pcs)  
 Hex Screws pos: 491, 492 (4 pcs)

#### Bearing spare part kit contain:

Tap Rol Bearing pos: 460, 470  
 Lock washer pos: 474  
 Round nut pos: 475

\*Kit contain 100 pcs

\*\* New design of guide spacer from  
 2023-04-01, Require no shims

#### Shim kit contain:

Shims pos: 488 (1 pcs on each side)

## F11-10

Pos	Part No	Description	Qty	Remarks
<b>Housing parts</b>				
110	3703010	Barrel Housing Assy Type B	1	Require item 130
110	3704105	Barrel Housing Assy Type U	1	Require item 130
130		Hex Socket Plug Assy BSP	1	VSTI3/8EDVITCF
130		Hex Socket Plug Assy UN	1	6 HP50N-S
211	3700905	Bearing Housing Type C	1	
211	3783242	Bearing Housing Type S	1	
211	3784906	Bearing Housing Type X	1	Saw motor flange
486	3723141**	Guide Spacer	1	
<b>Rotating parts</b>				
310	3796083	Shaft Assy type D	1	
310	3796080	Shaft Assy type K	1	Require item 321
310	3785221	Shaft Assy type S	1	
321	3724441*	Flat Key type K	1	
452	3795832	Ring Gear	1	

For other parts please contact Parker Hannifin

#### Seal kits

3783269	Sealing kit type V FPM
3797111	Sealing kit type N NBR
3783383	Sealing kit type S PTFE

#### Repair Spare part Kit

3721304	Type M (Motor)
3721305	Type S (High speed Motor)
3723957	Type H (High pressure Motor)
3723958	Type L (CCW pump)
3723959	Type R (CW pump)

#### Bearing spare part kit

3723968	Bearing kit
---------	-------------

#### Shim kit

3721346	Shims kit 0,8 mm
---------	------------------

#### Seal kit contain:

O-rings pos: 221, 222  
 Shaft seal pos: 233  
 Back-up Ring pos: 236  
 Retaining rings pos: 237

#### Repair spare part kit contain:

Valve plate pos: 121  
 Cylinder Barrel pos: 411  
 Barrel Retaining Ring pos: 431  
 Pistons pos: 440 (5 pcs)  
 Hex Screws pos: 491, 492 (4 pcs)

#### Bearing spare part kit contain:

Tap Rol Bearing pos: 460, 470  
 Lock washer pos: 474  
 Round nut pos: 475

#### Shim kit contain:

Shims pos: 488 (1 pcs on each side)

\*Kit contain 100 pcs

\*\* New design of guide spacer from  
 2023-04-01, Require no shims

Pos	Part No	Description	Qty	Remarks
<b>Housing parts</b>				
110	3783214	Barrel Housing Assy Type B	1	Require item 130
130		Hex Socket Plug Assy BSP	1	VSTI3/8EDVITCF
211	3700905	Bearing Housing Type C	1	
211	3783242	Bearing Housing Type S	1	
486	3723141**	Guide Spacer	1	
<b>Rotating parts</b>				
310	3796083	Shaft Assy type D	1	
310	3796080	Shaft Assy type K	1	Require item 321
310	3785221	Shaft Assy type S	1	
321	3724441*	Flat Key type K	1	
452	3795832	Ring Gear	1	

For other parts please contact Parker Hannifin

#### Seal kits

3783269	Sealing kit type V FPM
3797111	Sealing kit type N NBR
3783383	Sealing kit type S PTFE

#### Repair Spare part Kit

3723960	Type Q (Low noise motor)
3721358	Type S (High speed Motor)
3723962	Type L (CCW pump)
3723963	Type R (CW pump)

#### Bearing spare part kit

3723968	Bearing kit
---------	-------------

#### Shim kit

3721346	Shims kit 0,8 mm
---------	------------------

#### Seal kit contain:

O-rings pos: 221, 222  
 Shaft seal pos: 233  
 Back-up Ring pos: 236  
 Retaining rings pos: 237

#### Repair spare part kit contain:

Valve plate pos: 121  
 Cylinder Barrel pos: 411  
 Barrel Retaining Ring pos: 431  
 Pistons pos: 440 (5 pcs)  
 Hex Screws pos: 491, 492 (4 pcs)

#### Bearing spare part kit contain:

Tap Rol Bearing pos: 460, 470  
 Lock washer pos: 474  
 Round nut pos: 475

\*Kit contain 100 pcs

\*\* New design of guide spacer from  
 2023-04-01, Require no shims

#### Shim kit contain:

Shims pos: 488 (1 pcs on each side)



## F11-14

Pos	Part No	Description	Qty	Remarks
<b>Housing parts</b>				
110	3783214	Barrel Housing Assy Type B	1	Require item 130
130		Hex Socket Plug Assy BSP	1	VSTI3/8EDVITCF
211	3783240	Bearing Housing Type C	1	
211	3783223	Bearing Housing Type S	1	
211	3784908	Bearing Housing Type W	1	Saw motor flange
486	3723141**	Guide Spacer	1	
<b>Rotating parts</b>				
310	3782825	Shaft Assy type K	1	Require item 321
310	3783281	Shaft Assy type S	1	
310	3783282	Shaft Assy type T	1	Require item 321
310	3783382	Shaft Assy type X	1	For housing 3784908
321	3724443*	Flat Key type K	1	
321	3724449*	Flat Key type T	1	
321	3724437*	Flat Key type X	1	For shaft 3783382
452	3795832	Ring Gear	1	

**For other parts please contact  
Parker Hannifin**

<b>Seal kits</b>	
3785038	Sealing kit type V FPM
3721538	Sealing kit type S PTFE
<b>Repair Spare part Kit</b>	
3723960	Type Q (Low noise motor)
3721358	Type S (High speed Motor)
3723962	Type L (CCW pump)
3723963	Type R (CW pump)
<b>Bearing spare part kit</b>	
3723968	Bearing kit
<b>Shim kit</b>	
3721346	Shims kit 0,8 mm

**Seal kit contain:**

O-rings pos: 221, 222  
 Shaft seal pos: 233  
 Back-up Ring pos: 236  
 Retaining rings pos: 237

**Repair spare part kit contain:**

Valve plate pos: 121  
 Cylinder Barrel pos: 411  
 Barrel Retaining Ring pos: 431  
 Pistons pos: 440 (5 pcs)  
 Hex Screws pos: 491, 492 (4 pcs)

**Bearing spare part kit contain:**

Tap Rol Bearing pos: 460, 470  
 Lock washer pos: 474  
 Round nut pos: 475

**Shim kit contain:**

Shims pos: 488 (1 pcs on each side)

\*Kit contain 100 pcs

\*\* New design of guide spacer from  
 2023-04-01, Require no shims

Pos	Part No	Description	Qty	Remarks
<b>Housing parts</b>				
110	3704782	Barrel Housing Assy Type B	1	Require item 130
130		Hex Socket Plug Assy BSP	1	VSTI3/8EDVITCF
211	3788269	Bearing Housing Type C	1	
211	3784910	Bearing Housing Type X	1	Saw motor flange
486	3723210**	Guide Spacer	1	
<b>Rotating parts</b>				
310	3796087	Shaft Assy type K	1	Require item item 321
310	3796092	Shaft Assy type S	1	
310	3796089	Shaft Assy type T	1	Require item item 321
310	3797255	Shaft Assy type X	1	For housing 3784910
321	3724443*	Flat Key type K	1	
321	3724449*	Flat Key type T	1	
321	3724437*	Flat Key type X	1	For shaft 3797255
452	3795833	Ring Gear	1	

### For other parts please contact

#### Parker Hannifin

#### Seal kits

3783270	Sealing kit type V FPM
3783384	Sealing kit type S PTFE
3797112	Sealing kit type N NBR

#### Repair Spare part Kit

3721306	Type M (Motor)
3721267	Type S (High speed Motor)
3723964	Type H (High pressure Motor)
3723965	Type L (CCW pump)
3723966	Type R (CW pump)

#### Bearing spare part kit

3723969	Bearing kit standard
3723970	Bearing kit housing 3784910

#### Shim kit

3721347	Shims kit 0,8 mm
---------	------------------

#### Seal kit contain:

O-rings pos: 221, 222  
 Shaft seal pos: 233  
 Back-up Ring pos: 236  
 Retaining rings pos: 237

#### Repair spare part kit contain:

Valve plate pos: 121  
 Cylinder Barrel pos: 411  
 Barrel Retaining Ring pos: 431  
 Pistons pos: 440 (5 pcs)  
 Hex Screws pos: 491, 492 (4 pcs)

#### Bearing spare part kit contain:

Tap Rol Bearing pos: 460, 470  
 Lock washer pos: 474  
 Round nut pos: 475

#### Shim kit contain:

Shims pos: 488 (1 pcs on each side)

\*Kit contain 100 pcs

\*\* New design of guide spacer from  
 2023-02-01, Require no shims

## How to Properly Select a F11/F12 Spare Part

The first page of spare parts bulletin will display a “split view” drawing with the parts identified with numbers shown in red below.

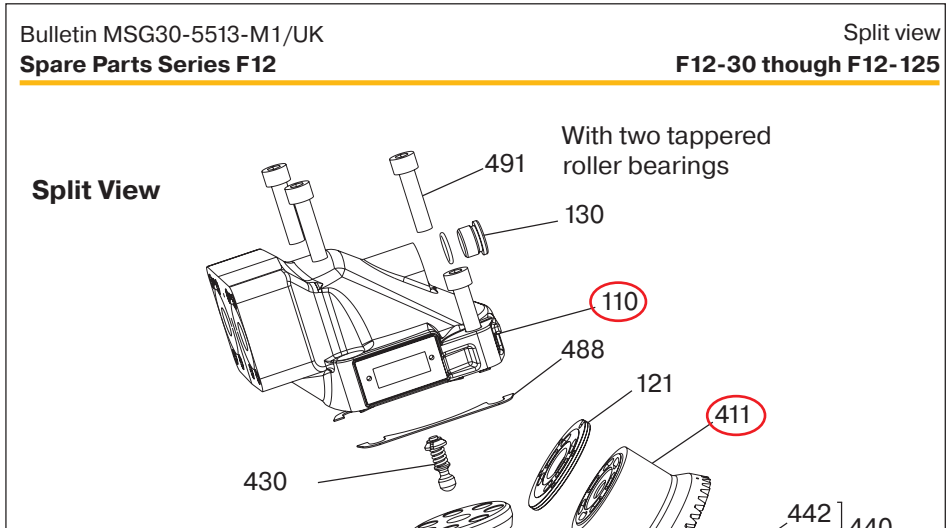

For our example we will be using the description F12-030-MS-SV-T-000-0000-P0 which has the part number 3721581 associated with it.

The part number is the number used to order the motor and takes precedence over the description.

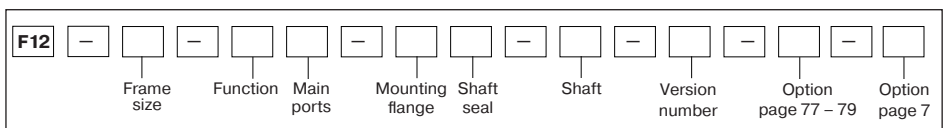

The pages we may need to use are the “split view” and the parts list for the particular motor size. In our example **F12-030-MS-SV-T-000-0000-P0**, “**F12-030**” is the size of the motor, and we need to turn to that particular page.

Bulletin MSG30-5513-M1/UK

Service Manual/Spare Parts

**Spare Parts Series F12**

**F12-30**

**F12-030 all types from serial no. 201809300001 and up.**

Pos	Part No	Description	Qty	Remarks
-----	---------	-------------	-----	---------

The motor must be within the serial number range (red line) Serial number is described as YYYYMMDD\*\*\*\*. Always contact Parker Division if your unit is produced prior to serial number

*The columns are defined as:*

- Pos. - The number from the split view that identifies the part
- Part Number - The number needed to purchase that part
- Description - The description of the part and the matching model code character
- Quantity - The number of that particular part you need to order for one unit
- Remarks - These can give you extra information to define the part

For motor F12-030-MS-SV-T-000-0000-P0 we need the barrel housing, shaft, and shaft seal.

For the barrel housing we can find the part a couple of ways. If there is visual recognition of the part, then the item number can be found by looking at the “split view” of the motor and locating the item number. In this case it is number 110.

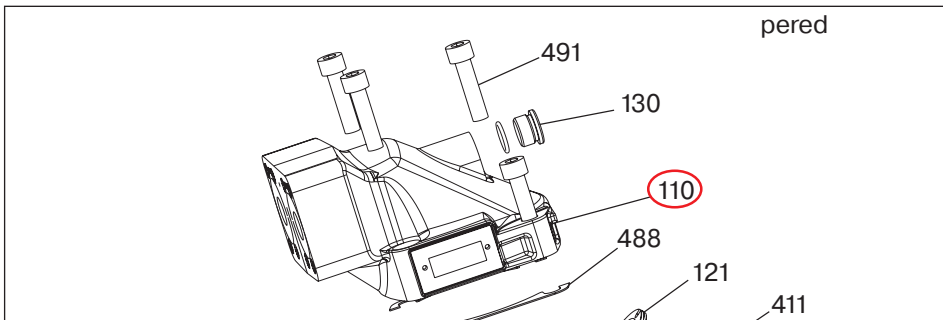

Pos	Part No	Description	Qty	Remarks
<b>Housing parts</b>				
61		Hex Socket Plug M12*1	1	VSTI12X1EDVITCF
110	3721864	Barrel Housing Assy Type F	1	
110	3721863	Barrel Housing Assy Type S	1	
130		Hex Socket Plug for S housing	1	8 HP50N-S
130		Hex Socket Plug for F housing	1	VSTI18X1,5EDVITCF

The other way is to know the name of the part, barrel housing assy (red type), and look at the parts listing for the description.

The red S in the description matches our model number F12-030-MS-SV-T-000-0000-P0 and has part number 3721863 (in green), quantity 1. Note that the Hex socket plug is not included, should be ordered from Parker Fitting division (in blue)

The shaft is the next item to be found. Looking for it visually in the "split view" we can determine that the shaft is item number 310.

We can refer to the parts list for the name of the part, shaft (red type), and look at the parts listing for the description.

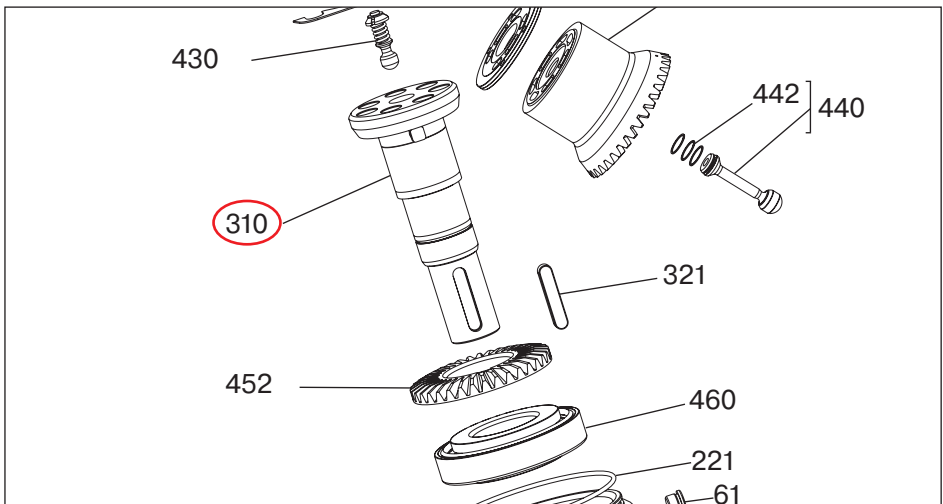

Pos	Part No	Description	Qty	Remarks
310	3799644	Shaft type P	1	Require flat key
310	3799634	Shaft type S	1	
310	3799640	Shaft type T	1	Require flat key
321	3724437*	Flat Key for K and P shaft	1	

The blue T in the description matches our model number F12-030-MS-SV-T-000-0000-P0 and has part number 3799640 (in green), quantity 1.

In the remarks (orange text) we have a note that states "Require Flat Key". We can offer that part to the customer, Flat keys must always be order with Minimum Order Quantity (MOQ)

Pos	Part No	Description	Qty	Remarks
321	3724437*	Flat Key for K and P shaft	1	
321	3724449*	Flat Key for T shaft	1	

The blue T in the description matches our model number F12-030-MS-SV-T-000-0000-P0 and has part number 3724449 (in green), quantity 1.

The shaft seal is the next item to be found. Looking for it visually in the "split view" we can determine that the shaft is item number 233.

We can refer to the parts list for the name of the part, shaft seal item 233 (red circle), and look at the parts listing for the description.

Some parts are not sold as separate items and will only be available in kits.

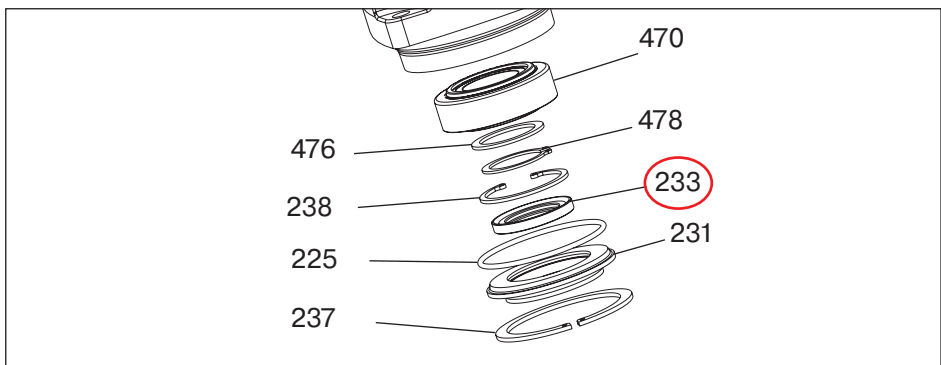

		<b>Seal kit contain:</b> O-rings pos: 221, 225, 229 Shaft seal pos: 233 Retaining rings pos: 237, 238
<b>Seal kits</b> 3793493 Sealing kit type V FPM 3785132 Sealing kit type N NBR 3784552 Sealing kit type S PTFE 3720898 Sealing kit type S SuperCut 100		<b>Repair spare part kit contain:</b> Valve plate pos: 121 Cylinder Barrel pos: 411 Pistons pos: 440 (7 pcs) Hex Screws pos: 491 (4 pcs)
<b>Repair Spare part Kit</b> 3721446 Type M (Motor) 3722010 Type S (High speed Motor) 3723977 Type L (CCW pump) 3723978 Type R (CW pump)		<b>Bearing spare part kit contain:</b> Tap Rol Bearing pos: 460, 470 Spacer pos: 476 Retaining rings pos: 478
<b>Bearing spare part kit</b> 3723971 Bearing kit		<b>Shim kit contain:</b> Shims pos: 488 (1 pcs on each side)
<b>Shim kit</b> 3721330 Shims kit		
*Kit contain 100 pcs, **Kit contain 20 pcs		

In the Kits section, we need to look at the right to determine which parts is required based on pos number. In this example we would like to get pos 233, shaft seal. Then it's only available in a seal kit and not sold as separate item. Some kits can be sold with MOQ.

We are looking for a shaft seal item 233, and there appears to be 2 seal kits to chose between. The model code calls out a V, F12-030-MS-SV-T-000-0000-P0, and it matches the seal kit with the V so our part number must be 3793493.

*If your requested part is not listed in Spare part list, always consult with Parker Division*

## Additional Information



Catalogue Hydraulic motor/pump  
series F10/F11/F12  
MSG30-8249/UK



Manual Speed Sensor  
Series F10/F11/F12 and V12/V14,  
Valid for sensor 3722480  
MSG30-8304-INST



Manual Speed Sensor  
Series F10/F11/F12 and V12/V14,  
Valid for sensor 3783883  
MSG30-8302-INST



Manual Speed Sensor -  
Series F10/F11/F12 and V12/V14,  
Valid for sensor 3785190  
MSG30-8301-INST



Manual Speed Sensor  
Series F10/F11/F12 and V12/V14,  
Valid for sensor 3722481  
MSG30-8303-INST



## Declaration

### Position notification regarding Machinery Directive 2006/42/EC:

Products made by the Hydraulic Pumps & Motors Europe (HPME) of Parker Hannifin are excluded from the scope of the machinery directive following the "Cetop" Position Paper on the implementation of the Machinery Directive 2006/42/EC in the Fluid Power Industry.

All HPME products are designed and manufactured considering the basic as well as the proven safety principles according to:

- ISO 13849-1:2015
- SS-EN ISO 4413:2010

so that the machines in which the products are incorporated meet the essential health and safety requirements.

Confirmations for components to be proven component, e. g. for validation of hydraulic systems, can only be provided after an analysis of the specific application, as the fact to be a proven component mainly depends on the specific application.

#### Christian Jäger

General Manger

Hydraulic Pumps & Motors Europe



### **WARNING – USER RESPONSIBILITY**

FAILURE OR IMPROPER SELECTION OR IMPROPER USE OF THE PRODUCTS DESCRIBED HEREIN OR RELATED ITEMS CAN CAUSE DEATH, PERSONAL INJURY AND PROPERTY DAMAGE.

This document and other information from Parker-Hannifin Corporation, its subsidiaries and authorized distributors provide product or system options for further investigation by users having technical expertise.

The user, through its own analysis and testing, is solely responsible for making the final selection of the system and components and assuring that all performance, endurance, maintenance, safety and warning requirements of the application are met. The user must analyze all aspects of the application, follow applicable industry standards, and follow the information concerning the product in the current product catalogue and in any other materials provided from Parker or its subsidiaries or authorized distributors.

To the extent that Parker or its subsidiaries or authorized distributors provide component or system options based upon data or specifications provided by the user, the user is responsible for determining that such data and specifications are suitable and sufficient for all applications and reasonably foreseeable uses of the components or systems.

### **Offer of Sale**

Please contact your Parker representation for a detailed "Offer of Sale".

**Parker Hannifin Manufacturing Sweden AB**

Hydraulic Pumps & Motors Europe

Flygmotorvägen 2

461 82 Trollhättan Sweden

Tel. +46 (0)520 40 45 00

[www.parker.com/msg](http://www.parker.com/msg)

MSG30-5511-M1/UK

11/2024

Your Local Authorized Parker Distributor

© 2025 Parker Hannifin Corporation

