

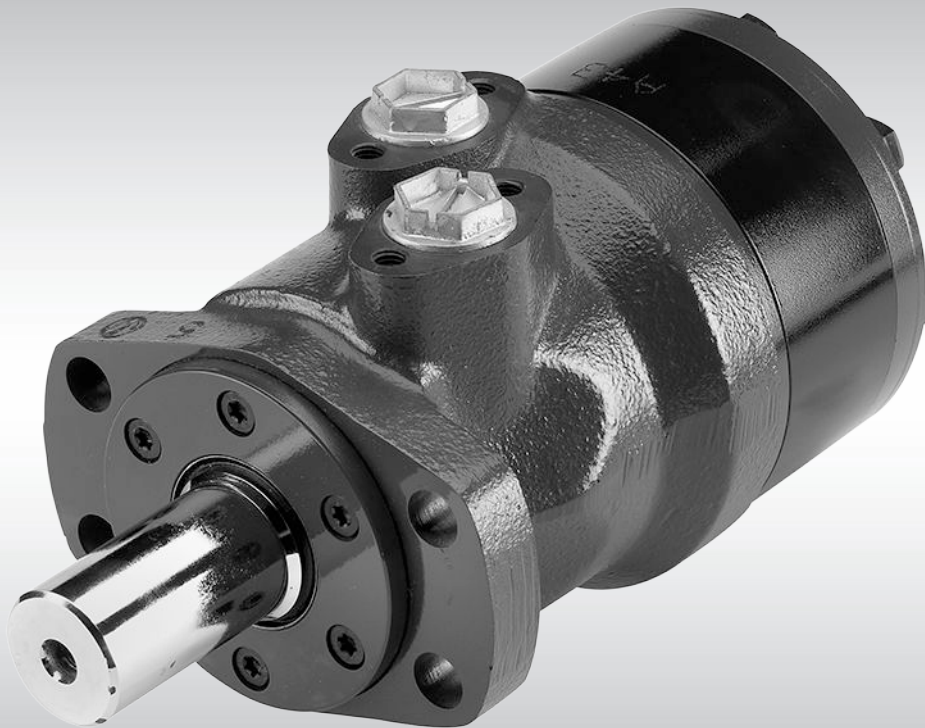

Technical Information

Orbital Motors

Type OMP, OMR and OMH



Revision history*Table of revisions*

Date	Changed	Rev
November 2014	Converted to Danfoss layout - DITA CMS	DA
Nov 2012	Planetary Gears deleted	CF
Sep 2011	Typo	CE
Sep 2010	New back cover	CD
Mar 2010	Japan location	CC
Jun 2007	Major revision with new lit-number (minus OMEW, will be prepared separately)	CA
Mar 2006	Small updates	B

Technical Information Orbital Motors Type OMP, OMR and OMH

Contents
A Wide Range of Hydraulics Motors

A Wide Range of Hydraulic Motors.....	6
Survey of Literature with Technical Data on Danfoss Hydraulic Motors.....	7
Speed, Torque and Output.....	8

Versions

Versions.....	9
Features available (options).....	9

Code Numbers

Code Numbers.....	10
-------------------	----

Technical Data

Technical data for OMP with 25 mm and 1 in cylindrical shaft.....	11
Technical data for OMP with 1 in splined and 28.5 mm tapered shaft.....	12
Technical data for OMP with 32 mm cylindrical shaft.....	13

Technical Data - Max. Permissible Shaft Seal Pressure

OMP with HIGH Pressure Shaft Seal (HPS).....	15
OMP with Standard Shaft Seal.....	15

Technical Data

Pressure Drop in Motor.....	17
Oil flow in drain line.....	17
Direction of Shaft Rotation.....	17
Permissible Shaft Load for OMP N.....	18
Permissible Shaft Load for OMPW with Slide Bearings.....	19
Permissible Shaft Load for OMPW N with Needle Bearing.....	19

Function Diagrams

Function Diagrams.....	21
OMP 60 under preparation	22
OMP 110 under preparation.....	23

Shaft Version

Shaft Version.....	25
--------------------	----

Port Thread Versions

Port Thread Versions.....	27
Manifold Mount.....	27

Dimensions - European Version

Dimensions.....	28
-----------------	----

Dimensions - US Version

Dimensions.....	32
-----------------	----

Dimensions - European Version

Dimensions.....	33
-----------------	----

Dimensions - US Version

Dimensions.....	35
-----------------	----

Dimensions - European Version

Dimensions.....	37
-----------------	----

Versions

Versions.....	39
Features available (options).....	40

Code Numbers

Code Numbers.....	41
-------------------	----

Technical Data

Technical data for OMR with 25 mm and 1 in cylindrical shaft.....	42
Technical data for OMR with 1 in splined and 28.5 mm tapered shaft.....	42
Technical data for OMR with 32 mm , 1 ¼ in cylindrical shaft and 35 mm, 1 ¼ in tapered shaft.....	43

Contents

Technical Data for Parking Brake Motor OMR F, OMR NF and OMRW NF.....	44
Function.....	44
Technical Data - Max. Permissible Shaft Seal Pressure	
OMR with High Pressure Shaft Seal (HPS).....	46
OMR with Standard Shaft Seal.....	46
Technical Data	
Pressure Drop in Motor.....	48
Oil flow in drain line.....	48
Direction of Shaft Rotation.....	48
Permissible Shaft Loads for OMR.....	48
Permissible Shaft Load for OMR N and OMR NF with Needle Bearings.....	49
Permissible Shaft Load for OMRW N and OMRW NF with Needle Bearings.....	50
Function Diagrams	
Function Diagrams.....	51
Shaft Version	
Shaft Version.....	54
Port Thread Versions	
Port Thread Versions.....	58
Manifold Mount.....	58
Dimensions-European version	
Dimensions.....	59
Dimension-US Version	
Dimensions.....	65
Dimensions-European Version	
Dimensions.....	67
Dimensions-US Version	
Dimensions.....	69
Dimensions-European Version	
Dimensions.....	71
Dimensions-US Version	
Dimensions.....	73
Dimensions-European Version	
Dimensions.....	75
Dimensions-US Version	
Dimensions.....	76
Dimensions-European Version	
Dimensions.....	77
Dimensions-US Version	
Dimensions.....	78
Dimensions-European Version	
Dimensions.....	79
Version	
Versions.....	81
Code Numbers	
Code Numbers.....	82
Technical Data	
Technical data for OMH with 1 in SAE 6 B splined shaft.....	83
Technical data for OMH with 32 mm and 1 1/4 in cylindrical shaft.....	83
Technical data for OMH with 35 mm cylindrical, 1 1/4 in splined and 35 mm tapered shaft.....	84

Technical Information Orbital Motors Type OMP, OMR and OMH

Contents

Max. Permissible Shaft Seal Pressure.....	85
Pressure Drop in Motor.....	86
Oil Flow in Drain Line.....	86
Direction of Shaft Rotation.....	87
Permissible Shaft Loads for OMH.....	87

Function Diagrams

Function Diagrams.....	88
------------------------	----

Shaft Version

Shaft Version.....	90
--------------------	----

Technical Data

Port Thread Versions.....	93
Manifold Mount.....	94

Dimensions-European Version

Dimensions.....	95
-----------------	----

Dimensions-US Version

Dimensions.....	96
-----------------	----

Weight of motors

Weight of Motors.....	97
-----------------------	----

A Wide Range of Hydraulics Motors

A Wide Range of Hydraulic Motors

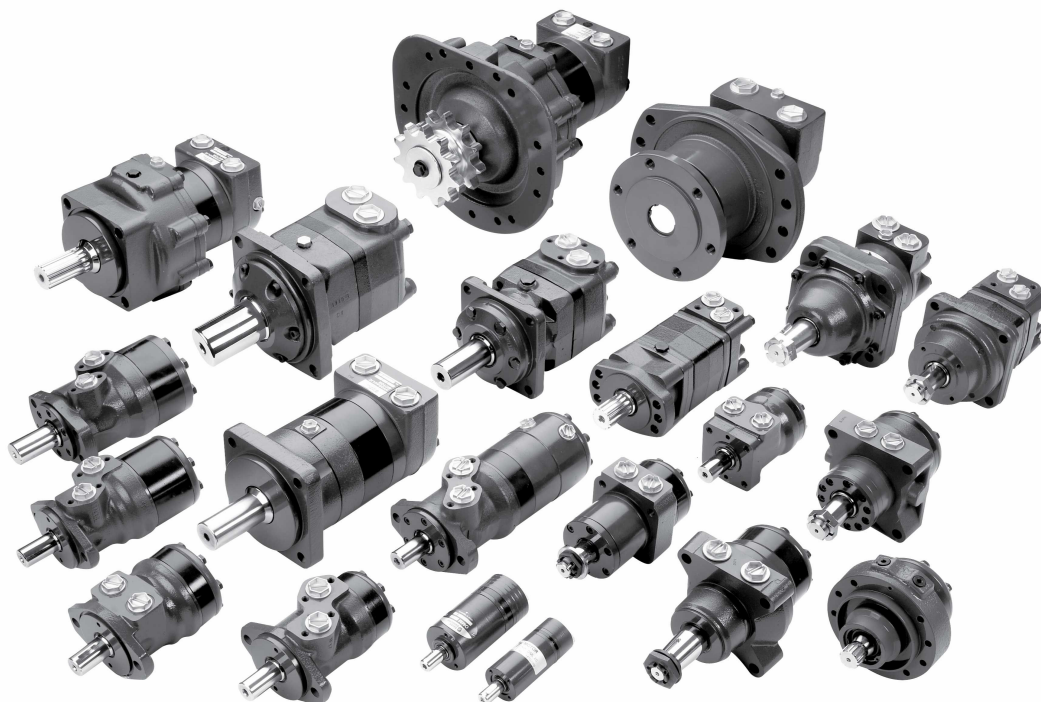

Danfoss is a world leader within production of low speed hydraulic motors with high torque. We can offer more than 3000 different hydraulic motors, categorised in types, variants and sizes (incl. different shaft versions).

The motors vary in size (rated displacement) from 8 cm³ [0.50 in³] to 800 cm³ [48.9 in³] per revolution.

Speeds range up to approx. 2500 min⁻¹ (rpm) for the smallest type and up to approx 600 min⁻¹ (rpm) for the largest type.

Maximum operating torques vary from 13 Nm [115 lbf-in] to 2700 Nm [24.000 lbf-in] (peak) and maximum outputs are from 2.0 kW [2.7 hp] to 70 kW [95 hp].

Characteristic features:

- Smooth running over the entire speed range
- Constant operating torque over a wide speed range
- High starting torque
- High return pressure without the use of drain line (High pressure shaft seal)
- High efficiency
- Long life under extreme operating conditions
- Robust and compact design
- High radial and axial bearing capacity
- For applications in both open and closed loop hydraulic systems
- Suitable for a wide variety of hydraulics fluids

The programme is characterised by technical features appealing to a large number of applications and a part of the programme is characterised by motors that can be adapted to a given application. Adaptions comprise the following variants among others:

A Wide Range of Hydraulics Motors

- Motors with corrosion resistant parts
- Wheel motors with recessed mounting flange
- OMP, OMR- motors with needle bearing
- OMR motor in low leakage version
- OMR motors in a super low leakage version
- Short motors without bearings
- Ultra short motors
- Motors with integrated positive holding brake
- Motors with integrated negative holding brake
- Motors with integrated flushing valve
- Motors with speed sensor
- Motors with tacho connection
- All motors are available with black finish paint

The Danfoss LSHT motors are used in the following application areas:

- Construction equipment
- Agricultural equipment
- Material handling & Lifting equipment
- Forestry equipment
- Lawn and turf equipment
- Special purpose
- Machine tools and stationary equipment
- Marine equipment

Survey of Literature with Technical Data on Danfoss Hydraulic Motors

Detailed data on all Danfoss motors can be found in our motor catalogue, which is divided into 8 individual subcatalogues:

- General information on Danfoss hydraulic motors: function, use, selection of hydraulic motor, hydraulic systems, etc.
- Technical data on small motors: OML and OMM
- Technical data on medium sized motors: OMP, OMR and OMH
- Technical data on medium sized motors: DH and DS
- Technical data on medium sized motors: OMEW
- Technical data on large motors: OMS, OMT and OMV
- Technical data on large motors: TMK
- Technical data on large motors: TMT
- Technical data on large motors: TMVW

A general survey brochure on Danfoss hydraulic motors gives a quick motor reference based on power, torque, speed and capabilities.

A Wide Range of Hydraulics Motors

Speed, Torque and Output

Max. speed, Max. torque, Max. output

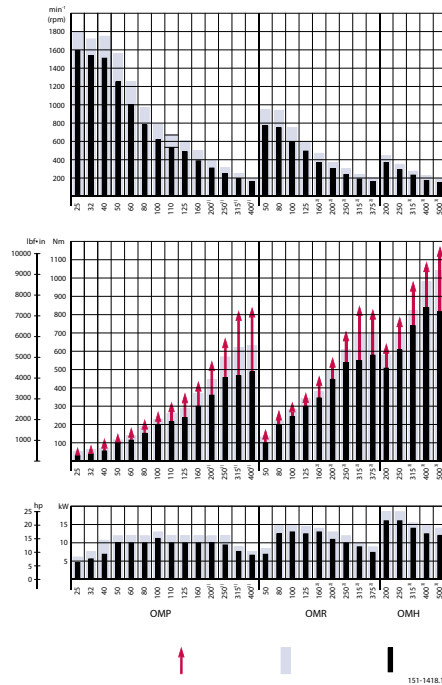

Peak value, Intermittend values, Continuous values

1. 1 1/4 in shaft
2. 1 1/4 in or 1 1/4 in tapered shaft
3. 1 1/4 in splined shaft

The bar diagrams above are useful for a quick selection of relevant motor size for the application. The final motor size can be determined by using the function diagram for each motor size.

- OMP and OMPW: see [Function Diagrams](#) on page 21
- OMR and OMRW: see [Function Diagrams](#) on page 51
- OMH: see [Function Diagrams](#) on page 88

The function diagrams are based on actual tests on a representative number of motors from our production. The diagrams apply to a return pressure between 5 and 10 bar.

[75 and 150 psi] when using mineral based hydraulic oil with a viscosity of $35 \text{ mm}^2/\text{s}$

[165 SUS] and a temperature of 50°C [120°F]. For further explanation concerning how to read and use the function diagrams, please consult the paragraph "Selection of motor size" in the technical information *General Orbital Motors 520L0232 Rev. B*.

Technical Information Orbital Motors Type OMP, OMR and OMH
Versions
Versions

Mounting flange	Spigot diameter (front /rear end)	Bolt circle diameter (BC)	Shaft	Port size	EU	US	Side port	End port	Flange port	Std. shaft seal	High pressure shaft seal	Drain connection	Check valve	Main type designation
2 hole oval flange (A2-flange)	Ø 82.5 mm [3.25 in]	Ø 106.4 mm [4.20 in]	Cyl. 25 mm	G ½	*		*				*	No	No	OMP
				G ½	*		*				*	Yes	No	OMP
				G ½	*			*			*	Yes	Yes	OMP
			Cyl. 1 inch	G ½	*		*				*	No	No	OMP
				G ½	*		*				*	Yes	No	OMP
				7/8 - 14 UNF		*	*				*	Yes	Yes	OMP
			Splined 1 inch	G ½	*		*				*	No	No	OMP
				G ½	*		*				*	Yes	No	OMP
4 hole oval flange (A4-flange)	Ø 82.5 mm [3.25 in]	Ø 106.4 mm [4.20 in]	Cyl. 32 mm	G ½	*		*			*	Yes	Yes	OMP	
Square flange (C-flange)	Ø 44.4 mm [1.75 in]	Ø 82.5 mm [3.25 in]	Cyl. 25 mm Cyl. 1 inch	G ½	*			*		*		Yes	Yes	OMP
				7/8 - 14 UNF		*	*			*	Yes	Yes	OMP	
				1/2 - 14 NPTF		*	*			*	Yes	Yes	OMP	
Wheel	Ø 80 mm [3.15 in]	Ø 103 mm [4.06 in]	Cyl. 25 mm	G ½	*				*	*	Yes	Yes	OMPW	
OMP motors with corrosion resistant parts														
2 hole oval flange (A2-flange)	Ø 82.5 mm [3.25 in]	Ø 106.4 mm [4.20 in]	Cyl. 25 mm	G ½	*		*			*		Yes	Yes	OMP C
OMP motors with needle bearings														
2 hole oval flange (A2-flange)	Ø 82.5 mm [3.25 in]	Ø 106.4 mm [4.20 in]	Cyl. 25 mm	G ½	*		*			*		Yes	Yes	OMP N
Wheel	Ø 80 mm [3.15 in]	Ø 103 [4.06]	Tap. 28.5 mm	G ½	*				*	*		Yes	Yes	OMPW N
OMP motors with free running gerotor														
2 hole oval flange (A2-flange)	Ø 82.5 mm [3.25 in]	Ø 106.4 mm [4.20 in]	Cyl. 25 mm	G ½	*		*			*		Yes	No	OMP

* Version is available.

Features available (options)

Low leakage (low speed valve)

Speed sensor

Viton shaft seal

Reverse rotation

Painted

Technical Information Orbital Motors Type OMP, OMR and OMH
Code Numbers
Code Numbers

Code numbers	Displacement [cm ³]													
	25	32	40	50	60	80	100	110	125	160	200	250	315	400
151-	0340	0341	0342	0310	0319	0311	0312	-	0313	0314	0315	0316	0317	0318
151-	0640	0641	0642	0610	-	0611	0612	0646	0613	0614	0615	0616	0617	0618
151-	-	-	-	5191	-	5192	5193	-	5194	5195	5196	5197	5198	5199
151-	-	-	-	0300	-	0301	0302	-	0303	0304	0305	0306	0307	0308
151-	-	-	-	0600	-	0601	0602	-	0603	0604	0605	0606	0607	0608
151-	7080	7081	7082	7041	-	7042	7043	-	7044*	7045	7046	7047	7048	7049
151-	-	-	-	0330	-	0331	0332	-	0333	0334	0335	0336	0337	0338
151-	-	-	-	0630	-	0631	0632	-	0633	0634	0635	0636	0637	0638
151-	-	5010	-	5001	-	5002	5003	-	5004	5005	5006	5007	5008	5009
151-	-	-	-	5211	-	5212	5213	-	5214	5215	5216	5217	5218	5219
151-	-	-	-	7061	-	7062	7063	-	5174	7065	7066	7067	7068	7069
151-	-	-	-	7021	-	7022	7023	-	7024	7025	7026	7027	7028	7029
151-	-	-	-	7101	-	7102	7103	-	7104	7105	7106	7107	7108	7109
OMP motors with corrosion resistant parts														
151-	-	-	-	1208	-	1209	1210	-	1217	1211	1212	1213	1214	1215
OMP motors with needle bearings														
151-	-	-	-	5311	-	5312	5313	-	-	5315	5316	-	5318	-
151-	-	-	-	5301	-	5302	5303	-	5304	5305	5306	5307	5308	5309
OMP motors with free running gerotor														
151-	-	-	-	-	-	-	0622	-	-	0624	0625	-	0627	-
	20	20	21	21	22	22	23	23	24	24	25	25	26	26

* Motor painted black

Ordering

Add the four digit prefix "151-" to the four digit numbers from the chart for complete code number.

Example:

151-0305 for an OMP 200 with A2 flange, cyl. 1 in shaft, port size G 1/2 and high pressure shaft seal.

Orders will not be accepted without the four digit prefix.

Technical Information Orbital Motors Type OMP, OMR and OMH
Technical Data
Technical data for OMP with 25 mm and 1 in cylindrical shaft

Type			OMP	OMP	OMP	OMP	OMP	OMP	OMP
Motor size			25	32	40	50	60	80	100
Geometric displacement	cm ³ [inch]		25.0 [1.53]	32.0 [1.96]	40.0 [2.45]	48.6 [2.97]	59.1 [3.61]	77.8 [4.76]	97.3 [5.95]
	Max. speed	min ⁻¹	cont.	1600	1560	1500	1230	1000	770
[rpm]		int. ¹⁾	1800	1720	1750	1540	1250	960	770
Max. torque	N·m [lbf·in]	cont.	33 [290]	43 [380]	52 [460]	93 [820]	115 [1020]	150 [1330]	190 [1680]
		int. ¹⁾	47 [420]	61 [540]	74 [660]	120 [1060]	140 [1240]	190 [1680]	230 [2040]
		peak ²⁾	67 [590]	86 [760]	107 [950]	140 [1240]	180 [1590]	220 [1950]	270 [2390]
Max. output	kW [hp]	cont.	4.5 [6.0]	5.8 [7.8]	7.0 [9.4]	10.0 [13.4]	10.0 [13.4]	10.0 [13.4]	11.0 [14.8]
		int. ¹⁾	6.1 [8.2]	7.8 [10.5]	10.6 [14.2]	12.0 [16.1]	12.0 [16.1]	12.0 [16.1]	13.0 [17.4]
Max. pressure drop	bar [psi]	cont.	100 [1450]	100 [1450]	100 [1450]	140 [2030]	140 [2030]	140 [2030]	140 [2030]
		int. ¹⁾	140 [2030]	140 [2030]	140 [2030]	175 [2540]	175 [2540]	175 [2540]	175 [2540]
		peak ²⁾	225 [3260]	225 [3260]	225 [3260]	225 [3260]	225 [3260]	225 [3260]	225 [3260]
Max. oil flow	l/min [US gal/min]	cont.	40 [10.6]	50 [13.2]	60 [15.9]	60 [15.9]	60 [15.9]	60 [15.9]	60 [15.9]
		int. ¹⁾	45 [11.9]	55 [14.5]	70 [18.5]	75 [19.8]	75 [19.8]	75 [19.8]	75 [19.8]
Max. starting pressure with bar unloaded shaft [psi]	standard		10 [145]	10 [145]	10 [145]	10 [145]	10 [145]	10 [145]	10 [145]
	free running gerotor		-	-	-	-	-	-	2 [29]
Min starting torque	at max. press drop cont. N·m [lbf·in]		30 [270]	40 [350]	45 [400]	80 [710]	100 [885]	135 [1200]	170 [1510]
	at max. press.drop int. ¹⁾ N·m [lbf·in]		40 [350]	55 [490]	63 [560]	100 [890]	120 [1060]	170 [1510]	210 [1860]

¹⁾ Intermittent operation: the permissible values may occur for max. 10% of every minute.

²⁾ Peak load: the permissible values may occur for max. 1% of every minute.

Type			OMP	OMP	OMP	OMP	OMP	OMP	OMP
Motor size			110	125	160	200	250	315	400
Geometric displacement	cm ³ [inch]		112.5 [6.87]	125.0 [7.65]	155.7 [9.53]	194.6 [11.91]	242.3 [14.83]	306.1 [18.73]	389.2 [23.82]
	Max. speed	min ⁻¹	cont.	535	480	385	310	250	195
[rpm]		int. ¹⁾	670	600	480	385	310	245	190

Technical Information Orbital Motors Type OMP, OMR and OMH
Technical Data

Type			OMP	OMP	OMP	OMP	OMP	OMP	OMP
Motor size			110	125	160	200	250	315	400
Max. torque	N•m [lbf•in]	cont.	215 [1900]	240 [2120]	300 [2660]	300 [2660]	300 [2660]	300 [2660]	300 [2660]
		int. ¹⁾	260 [2300]	290 [2570]	370 [3280]	380 [3360]	410 [3630]	390 [3450]	420 [3720]
		peak ²⁾	320 [2830]	370 [3280]	430 [3810]	540 [4780]	550 [4870]	600 [5310]	600 [5310]
Max. output	kW [hp]	cont.	10 [13.4]	10 [13.4]	10 [13.4]	8.0 [10.7]	6.0 [8.1]	5.0 [6.7]	4.0 [5.4]
		int. ¹⁾	12.0 [16.1]	12.0 [16.1]	12.0 [16.1]	11.0 [14.8]	9.0 [12.1]	7.0 [9.4]	6.0 [8.1]
Max. pressure drop	bar [psi]	cont.	140 [2030]	140 [2030]	140 [2030]	115 [1670]	90 [1310]	75 [1090]	60 [870]
		int. ¹⁾	175 [2540]	175 [2540]	175 [2540]	150 [2180]	125 [1810]	100 [1450]	80 [1160]
		peak ²⁾	225 [3260]	225 [3260]	225 [3260]	225 [3260]	180 [2610]	160 [2320]	130 [1890]
Max. oil flow	l/min [US gal/min]	cont.	60 [15.9]	60 [15.9]	60 [15.9]	60 [15.9]	60 [15.9]	60 [15.9]	60 [15.9]
		int. ¹⁾	75 [19.8]	75 [19.8]	75 [19.8]	75 [19.8]	75 [19.8]	75 [19.8]	75 [19.8]
Max. starting pressure with bar unloaded shaft [psi]	standard		10 [145]	9 [130]	7 [100]	5 [75]	5 [75]	5 [75]	5 [75]
	free running gerotor		-	2 [29]	2 [29]	2 [29]	-	-	-
Min starting torque	at max. press drop cont. N•m [lbf•in]		190 [1680]	210 [1860]	280 [2480]	270 [2390]	280 [2480]	280 [2480]	280 [2480]
	at max. press.drop int. ¹⁾ N•m [lbf•in]		240 [2120]	270 [2390]	350 [3100]	360 [3190]	390 [3450]	370 [3280]	400 [3540]

¹⁾ Intermittent operation: the permissible values may occur for max. 10% of every minute.

²⁾ Peak load: the permissible values may occur for max. 1% of every minute.

Technical data for OMP with 1 in splined and 28.5 mm tapered shaft

Type			OMP	OMP	OMP	OMP	OMP	OMP	OMP	OMP	
Motor size			50	80	100	125	160	200	250	315	400
Geometric displacement	cm ³ [inch]		48.6 [2.97]	77.8 [4.76]	97.3 [5.95]	125.0 [7.65]	155.7 [9.53]	194.6 [11.91]	242.3 [14.83]	306.1 [18.73]	389.2 [23.82]
Max. speed	min ⁻¹	cont.	1230	770	615	480	385	310	250	195	155
	[rpm]	int. ¹⁾	1540	960	770	600	480	385	310	245	190
Max. torque	N•m [lbf•in]	cont.	93 [820]	150 [1330]	190 [1680]	240 [2120]	300 [2660]	360 [3190]	360 [3190]	360 [3190]	360 [3190]
		int. ¹⁾	120 [1060]	190 [1680]	230 [2040]	290 [2570]	370 [3280]	450 [3980]	460 [4070]	470 [4160]	460 [4070]
		peak ²⁾	140 [1240]	220 [1950]	270 [2390]	370 [3280]	430 [3810]	540 [4780]	550 [4870]	540 [4780]	560 [4960]

Technical Information Orbital Motors Type OMP, OMR and OMH
Technical Data

Type			OMP	OMP	OMP	OMP	OMP	OMP	OMP	OMP	OMP	
Motor size			50	80	100	125	160	200	250	315	400	
Max. output	kW [hp]	cont.	10.0 [13.4]	10.0 [13.4]	11.0 [14.8]	10.0 [13.4]	10.0 [13.4]	10.0 [13.4]	8.0 [10.7]	6.0 [8.0]	5.0 [6.7]	
		int. ¹⁾	12.0 [16.1]	12.0 [16.1]	13 [17.4]	12.0 [16.1]	12.0 [16.1]	12.0 [16.1]	12.0 [16.1]	10.5 [14.1]	7.5 [10.1]	6.0 [8.0]
Max. pressure drop	bar [psi]	cont.	140 [2030]	140 [2030]	140 [2030]	140 [2030]	140 [2030]	140 [2030]	140 [2030]	105 [1520]	90 [1310]	70 [1020]
		int. ¹⁾	175 [2540]	175 [2540]	175 [2540]	175 [2540]	175 [2540]	175 [2540]	175 [2540]	140 [2030]	120 [1740]	90 [1310]
		peak ²⁾	225 [3260]	225 [3260]	225 [3260]	225 [3260]	225 [3260]	225 [3260]	225 [3260]	180 [2610]	160 [2320]	130 [1890]
Max. oil flow	l/min [US gal/min]	cont.	60 [15.9]	60 [15.9]	60 [15.9]	60 [15.9]	60 [15.9]	60 [15.9]	60 [15.9]	60 [15.9]	60 [15.9]	60 [15.9]
		int. ¹⁾	75 [19.8]	75 [19.8]	75 [19.8]	75 [19.8]	75 [19.8]	75 [19.8]	75 [19.8]	75 [19.8]	75 [19.8]	75 [19.8]
Max. starting pressure with unloaded shaft	bar [psi]		10 [145]	10 [145]	10 [145]	9 [130]	7 [100]	5 [75]	5 [75]	5 [75]	5 [75]	
Min starting torque	at max. press drop cont. N•m [lbf•in]		80 [710]	135 [1200]	170 [1510]	210 [1860]	280 [2480]	340 [3010]	330 [2920]	340 [3010]	345 [3050]	
	at max. press.drop int. ¹⁾ N•m [lbf•in]		100 [890]	170 [1510]	210 [1860]	270 [2390]	350 [3100]	420 [3720]	440 [3890]	450 [3980]	425 [3760]	

¹⁾ Intermittent operation: the permissible values may occur for max. 10% of every minute.

²⁾ Peak load: the permissible values may occur for max. 1% of every minute.

Technical data for OMP with 32 mm cylindrical shaft

Type			OMP	OMP	OMP	OMP	OMP	OMP	OMP	OMP	OMP	
Motor size			50	80	100	125	160	200	250	315	400	
Geometric displacement	cm ³ [inch]		48.6 [2.97]	77.8 [4.76]	97.3 [5.95]	125.0 [7.65]	155.7 [9.53]	194.6 [11.91]	242.3 [14.83]	306.1 [18.73]	389.2 [23.82]	
Max. speed	min ⁻¹	cont.	1230	770	615	480	385	310	250	195	155	
	[rpm]	int. ¹⁾	1540	960	770	600	480	385	310	245	190	
Max. torque	N•m [lbf•in]	cont.	93 [820]	150 [1330]	190 [1680]	240 [2120]	300 [2660]	360 [3190]	460 [4070]	470 [4160]	490 [4340]	
		int. ¹⁾	120 [1060]	190 [1680]	230 [2040]	290 [2570]	370 [3280]	450 [3980]	570 [5050]	620 [5490]	630 [580]	
		peak ²⁾	140 [1240]	220 [1950]	270 [2390]	370 [3280]	430 [3810]	540 [4780]	670 [5930]	820 [7260]	840 [7440]	
Max. output	kW [hp]	cont.	10.0 [13.4]	10.0 [13.4]	11.0 [14.8]	10.0 [13.4]	10.0 [13.4]	10.0 [13.4]	9.5 [12.7]	7.5 [10.1]	6.5 [8.7]	
		int. ¹⁾	12.0 [16.1]	12.0 [16.1]	13.0 [17.4]	12.0 [16.1]	12.0 [16.1]	12.0 [16.1]	12.0 [16.1]	12.0 [16.1]	9.0 [12.1]	7.5 [10.1]
Max. pressure drop	bar [psi]	cont.	140 [2030]	140 [2030]	140 [2030]	140 [2030]	140 [2030]	140 [2030]	140 [2030]	140 [2030]	120 [1740]	95 [1380]
		int. ¹⁾	175 [2540]	175 [2540]	175 [2540]	175 [2540]	175 [2540]	175 [2540]	175 [2540]	175 [2540]	160 [2320]	125 [1810]
		peak ²⁾	225 [3260]	225 [3260]	225 [3260]	225 [3260]	225 [3260]	225 [3260]	225 [3260]	225 [3260]	225 [3260]	225 [3260]

Technical Information Orbital Motors Type OMP, OMR and OMH
Technical Data

Type			OMP	OMP	OMP	OMP	OMP	OMP	OMP	OMP	OMP
Motor size			50	80	100	125	160	200	250	315	400
Max. oil flow	l/min [US gal/min]	cont.	60 [15.9]	60 [15.9]	60 [15.9]	60 [15.9]	60 [15.9]	60 [15.9]	60 [15.9]	60 [15.9]	60 [15.9]
		int. ¹⁾	75 [19.8]	75 [19.8]	75 [19.8]	75 [19.8]	75 [19.8]	75 [19.8]	75 [19.8]	75 [19.8]	75 [19.8]
Max. starting pressure with unloaded shaft	bar [psi]		10 [145]	10 [145]	10 [145]	9 [130]	7 [100]	5 [75]	5 [75]	5 [75]	5 [75]
Min starting torque	at max. press drop cont. N•m [lbf•in]		80 [710]	135 [1200]	170 [1510]	210 [1860]	280 [2480]	340 [3010]	420 [3720]	460 [4070]	460 [4070]
	at max. press.drop int. ¹⁾ N•m [lbf•in]		100 [890]	170 [1510]	210 [1860]	270 [2390]	350 [3100]	420 [3720]	530 [4690]	600 [5310]	600 [5310]

¹⁾ Intermittent operation: the permissible values may occur for max. 10% of every minute.

²⁾ Peak load: the permissible values may occur for max. 1% of every minute.

Type		Max. inlet pressure	Max.return pressure with drain line
OMP 25 - 400	bar [psi] cont	175 [2540]	175 [2540]
	bar int. ¹⁾ [psi]	200 [2900]	200 [2900]
	bar peak ²⁾ [psi]	225 [3260]	225 [3260]

¹⁾ Intermittent operation: the permissible values may occur for max. 10% of every minute.

²⁾ Peak load: the permissible values may occur for max. 1% of every minute.

Technical Data - Max. Permissible Shaft Seal Pressure

OMP with HIGH Pressure Shaft Seal (HPS)

OMP with HPS and without drain connection:

The shaft seal pressure equals the average of input pressure and return pressure.

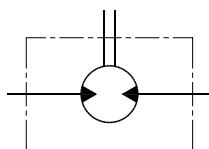

151-1743.10

$$P_{\text{seal}} = \frac{P_{\text{in}} + P_{\text{return}}}{2}$$

OMP with HPS and drain connection:

The shaft seal pressure equals the pressure in the drain line.

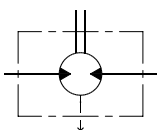

151-1855.10

Max. permissible shaft seal pressure

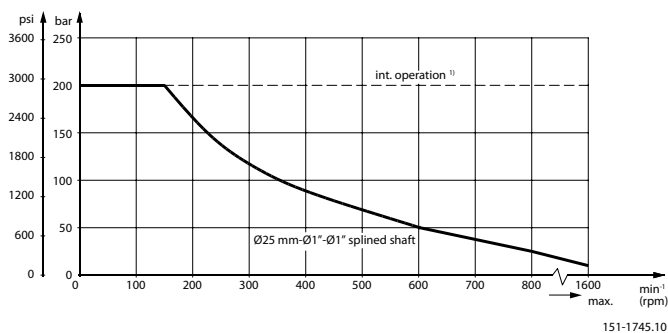

151-1745.10

OMP with Standard Shaft Seal

OMP with standard shaft seal, check valves and without use of drain connection:

The pressure on the shaft seal never exceeds the pressure in the return line

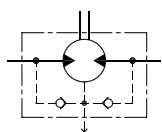

151-320.10

OMP with standard shaft seal, check valves and with drain connection:

The shaft seal pressure equals the pressure on the drain line.

Technical Data - Max. Permissible Shaft Seal Pressure

Max. return pressure without drain line or max. pressure in the drain line

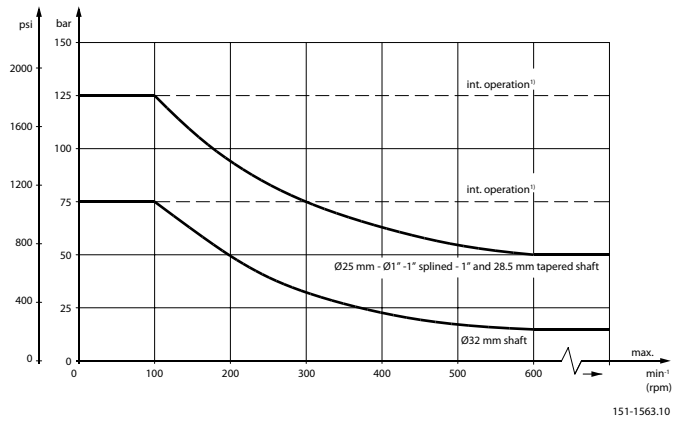

1) Intermittent operation: the permissible values may occur for max. 10% of every minute.

Technical Data
Pressure Drop in Motor

The curve applies to an unloaded motor shaft and an oil viscosity of 35 mm²/s [165 SUS]

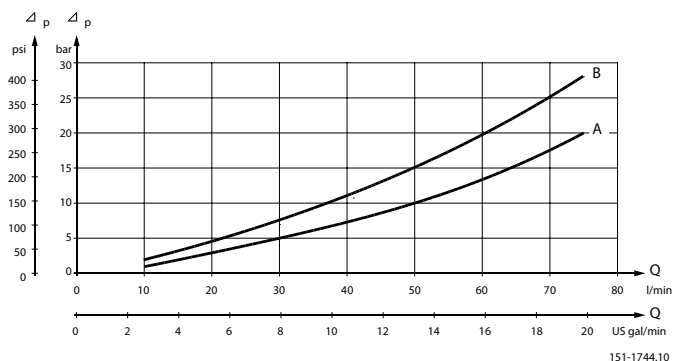

A: OMP 50 - 400

B: OMP 25 - 40 / OMPW

Oil flow in drain line

The table shows the max. oil flow in the drain line at a return pressure less than 5-10 bar [75-150 psi].

Pressure drop bar [psi]	Viscosity mm ² /s [SUS]	Oil flow in drain line l/min [US gal/min]
100 [1450]	20 [100]	2.5 [0.66]
	35 [165]	1.8 [0.78]
140 [2030]	20 [100]	3.5 [0.93]
	35 [165]	2.8 [0.74]

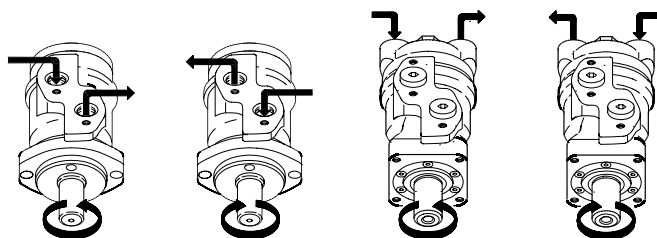
Direction of Shaft Rotation

151-1836.10

The permissible radial shaft load (PR) depends on

- Speed (n)
- Distance (L) from the point of load to the mounting flange
- Mounting flange version
- Shaft version

Mounting flange	4-oval flange** 2-hole oval flange (European version)	4-hole oval flange	Square flange** 2-hole oval flange (US-version)
-----------------	---	--------------------	---

Technical Information Orbital Motors Type OMP, OMR and OMH

Technical Data

Shaft version	25 mm cylindrical shaft 1 in cylindrical shaft 1 in splined shaft	32 mm cylindrical shaft	25 mm cylindrical shaft
Permissible shaft load (PR) - l in mm	800 250000 N* n 95 + L	800 187500 N* n 95 + L	800 250000 N* n 101 + L
Permissible shaft load (PR) - l in inch	800 2215 lbf* n 3.74 + L	800 1660 lbf* n 3.74 + L	800 2215 lbf* n 3.98 + L

* $n \geq 200 \text{ min}^{-1}$ [rpm]; $\leq 55 \text{ mm}$ [2.2 in]
 $n < 200 \text{ min}^{-1}$ [rpm]; $= > \text{PR}_{\text{max}} = 8000 \text{ N}$ [1800 lbf]
 ** For both European and US-version

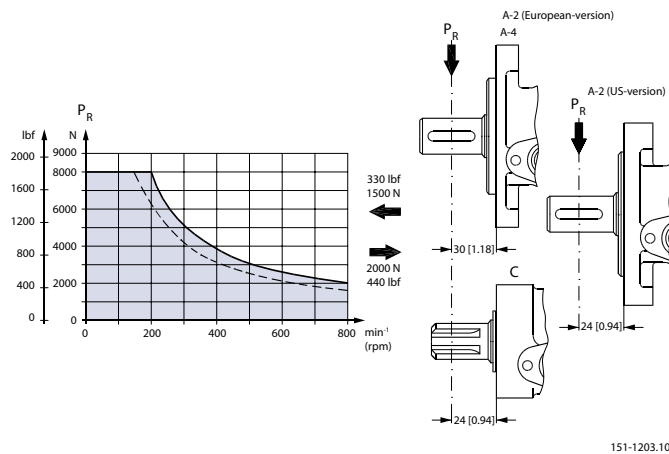

----- cylindrical shaft 32 mm [1.26 in]

_____ other shaft versions

The curve shows the relation between PR and n

- when $l = 30 \text{ mm}$ [1.18 in] for motors with A2 (European version) and A4 oval mounting flange
- when $l = 24 \text{ mm}$ [0.94 in] for motors with square mounting flange and A2 (US version)

For applications with special performance requirements we recommend OMP with the output shaft running in needle bearings.

Permissible Shaft Load for OMP N

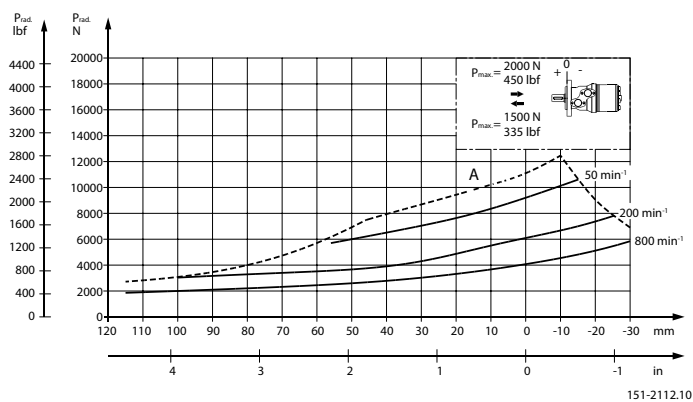

The output shaft on OMP N can be offered in needle bearings. These bearings and the recessed mounting flange allow a higher permissible radial load in comparison to OMP motors.

Technical Data

The permissible radial load on the shaft is shown for different speeds as a function of the distance from the mounting flange to the point of load application.

Curve A indicates the max. radial shaft load. Any shaft load exceeding the values quoted in curve A will involve risk of breakage.

The other curves apply to a B10 bearing life of 2000 hours at the number of revolutions indicated by the curve letter. Mineral based hydraulic oil with a sufficient content of anti-wear additives must be used.

Bearing life calculations can be made using the explanation and formula provided in the chapter "Bearing dimensioning" in the technical information "General Orbital Motors" 520L0232 Rev. B.

Permissible Shaft Load for OMPW with Slide Bearings

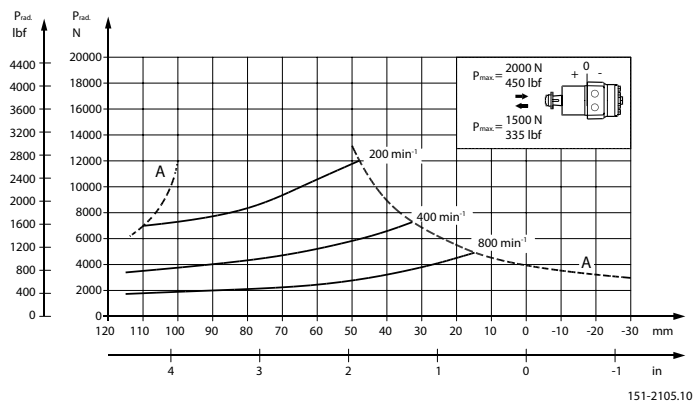

The output shaft on OMPW can be offered in slide bearings similar to the other OMP-motors. The permissible higher radial load is therefore due to the recessed mounting flange moving the point of load closer to the motor bearings.

The permissible radial load on the shaft is shown for different speeds as a function of the distance from the mounting flange to the point of load application.

The curves are not based on calculations of B10 bearing life. They represent absolute limits that must not be exceeded.

Curve A indicates the max. radial shaft load. Any shaft load exceeding the values quoted in curve A will involve risk of breakage.

Permissible Shaft Load for OMPW N with Needle Bearing

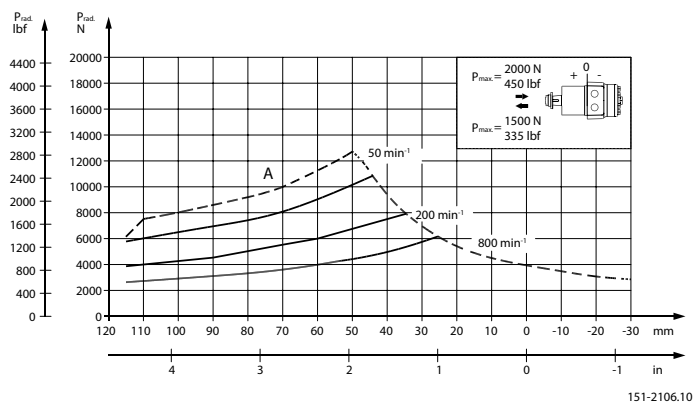

The output shaft on OMPW N can be offered in needle bearings. These bearings and the recessed mounting flange allow a higher permissible radial load in comparison to OMP motors.

Technical Data

The permissible radial load on the shaft is shown for different speeds as a function of the distance from the mounting flange to the point of load application.

Curve A indicates the max. radial shaft load. Any shaft load exceeding the values quoted in curve A will involve risk of breakage.

The other curves apply to a B10 bearing life of 2000 hours at the number of revolutions indicated by the curve letter. Mineral based hydraulic oil with a sufficient content of anti-wear additives must be used.

Bearing life calculations can be made using the explanation and formula provided in the chapter "Bearing dimensioning" in the technical information "General Orbital Motors" 520L0232 Rev. B.

Function Diagrams

Function Diagrams

Explanation of function diagram use, basis and conditions can be found in [Speed, Torque and Output](#) on page 8.

- Continuous range
- Intermittent range (max. 10% operation every minute)

Max. permissible continuous/intermittent pressure drop for the actual shaft version can be found in [Technical data for OMP with 25 mm and 1 in cylindrical shaft](#) on page 11.

Intermittent pressure drop and oil flow must not occur simultaneously.

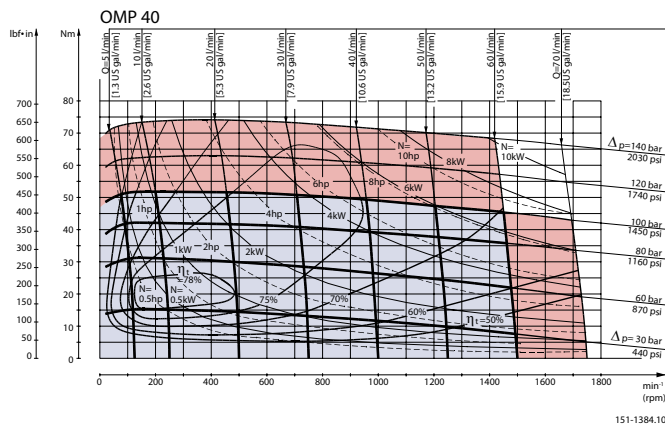
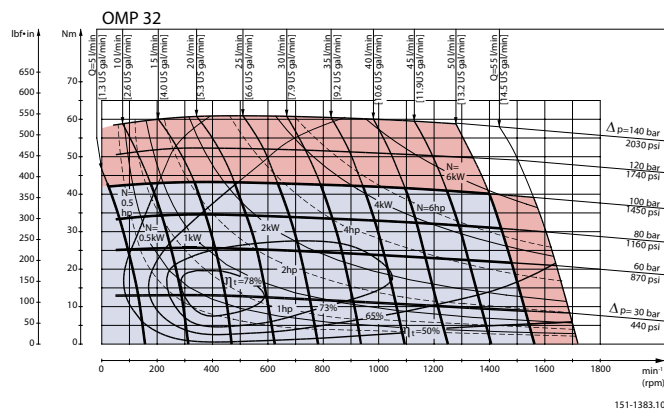
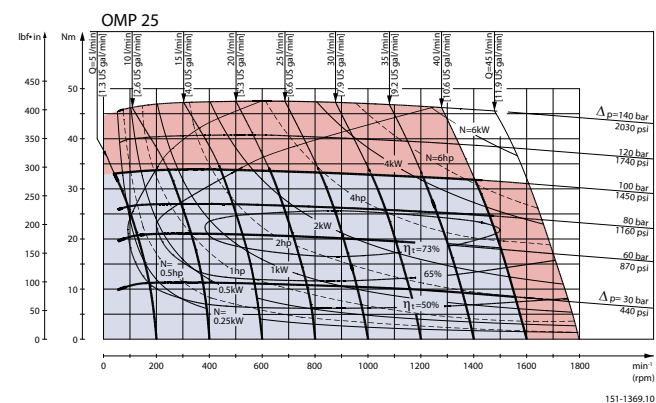

Function Diagrams

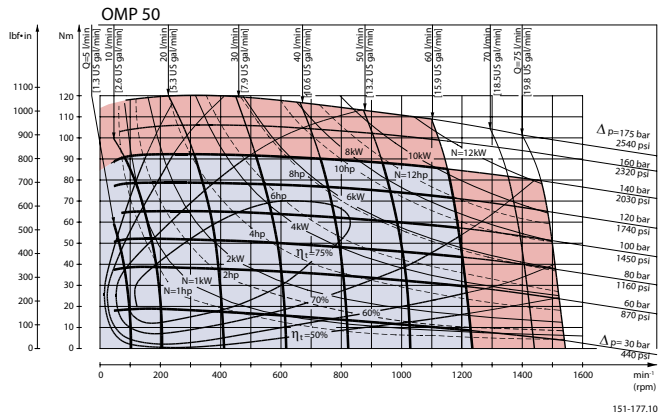

OMP 60 under preparation

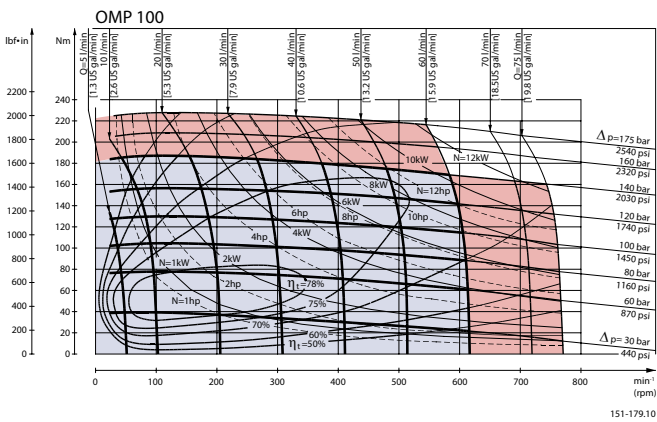
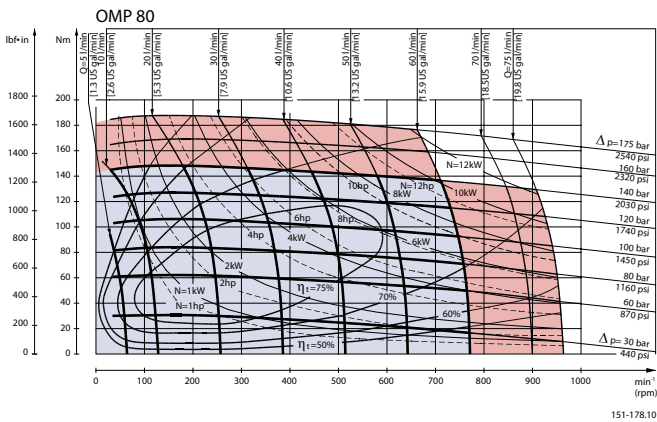

Function Diagrams

OMP 110 under preparation

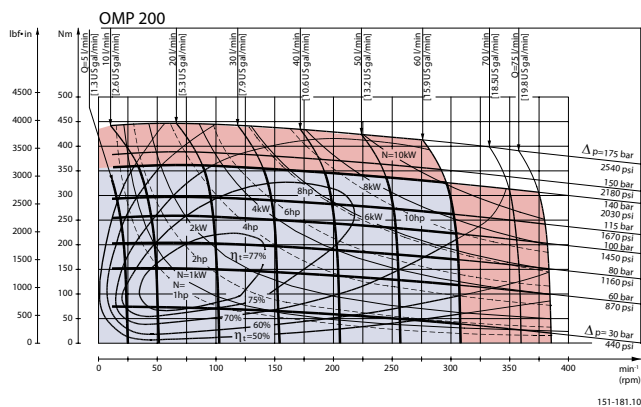
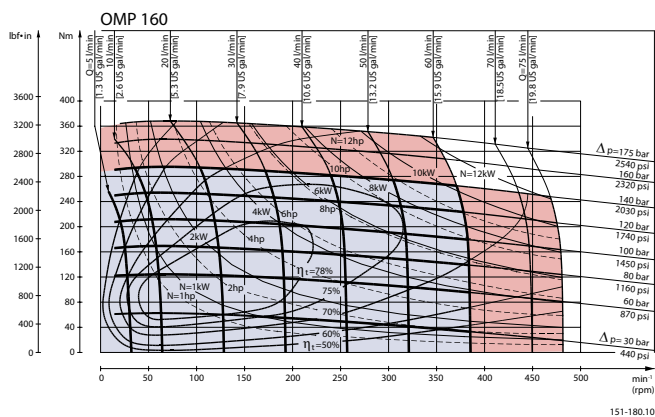
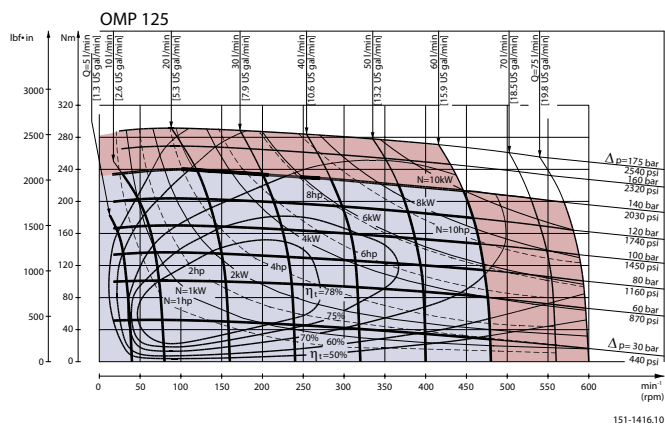

Function Diagrams

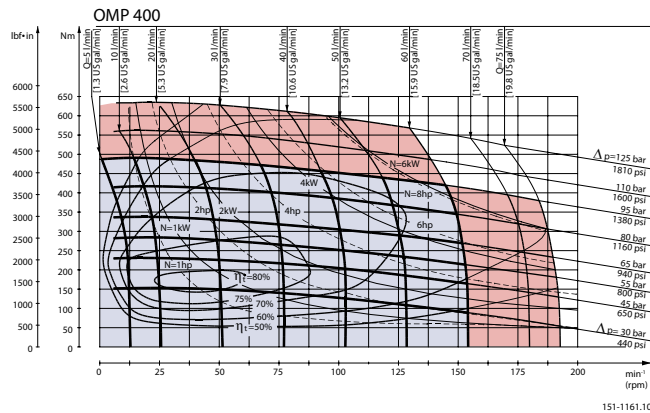
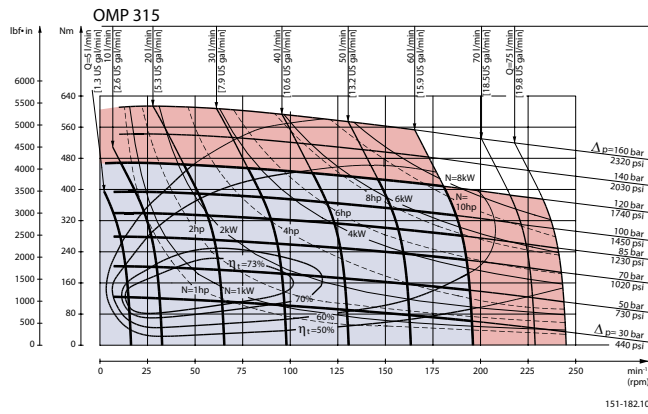
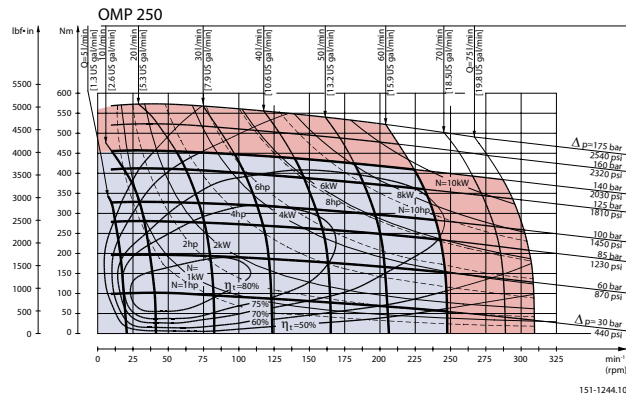

Shaft Version

Shaft Version

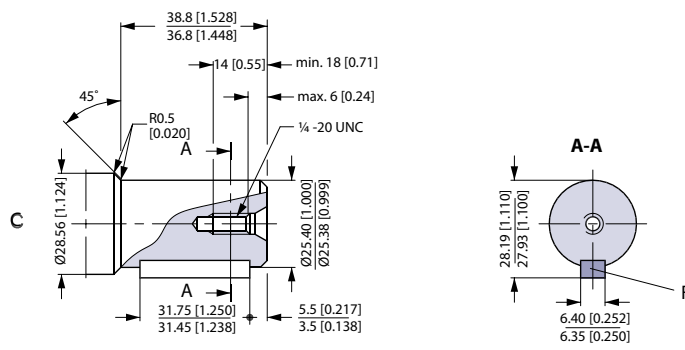
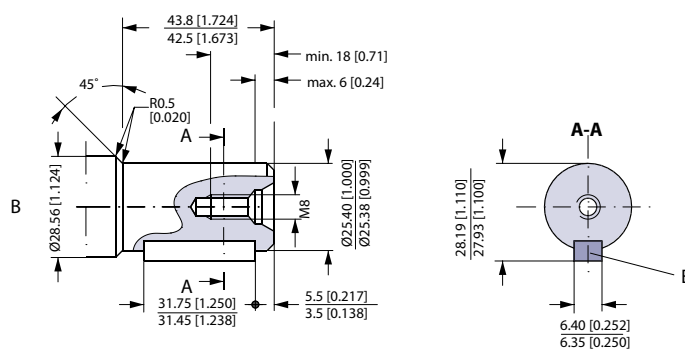
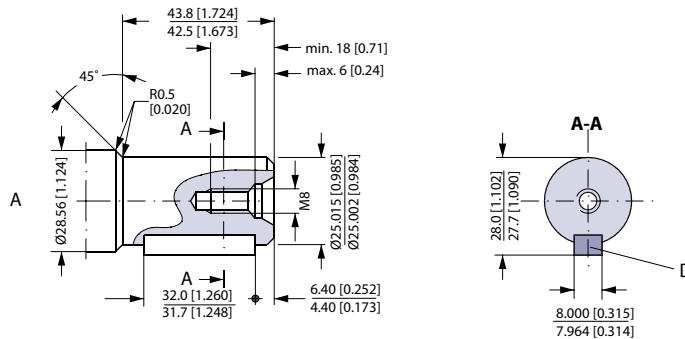

151-1842.12

A: Cylindrical shaft
25 mm

B: Cylindrical shaft
1 in

US version
C: Cylindrical shaft
1 in

D: Parallel key
A8 • 7 • 32
DIN 6885

E: Parallel key
1/4 • 1/4 • 11/4 in
B.S. 46

F: Parallel key
1/4 • 1/4 • 11/4 in
B.S. 46

Shaft Version

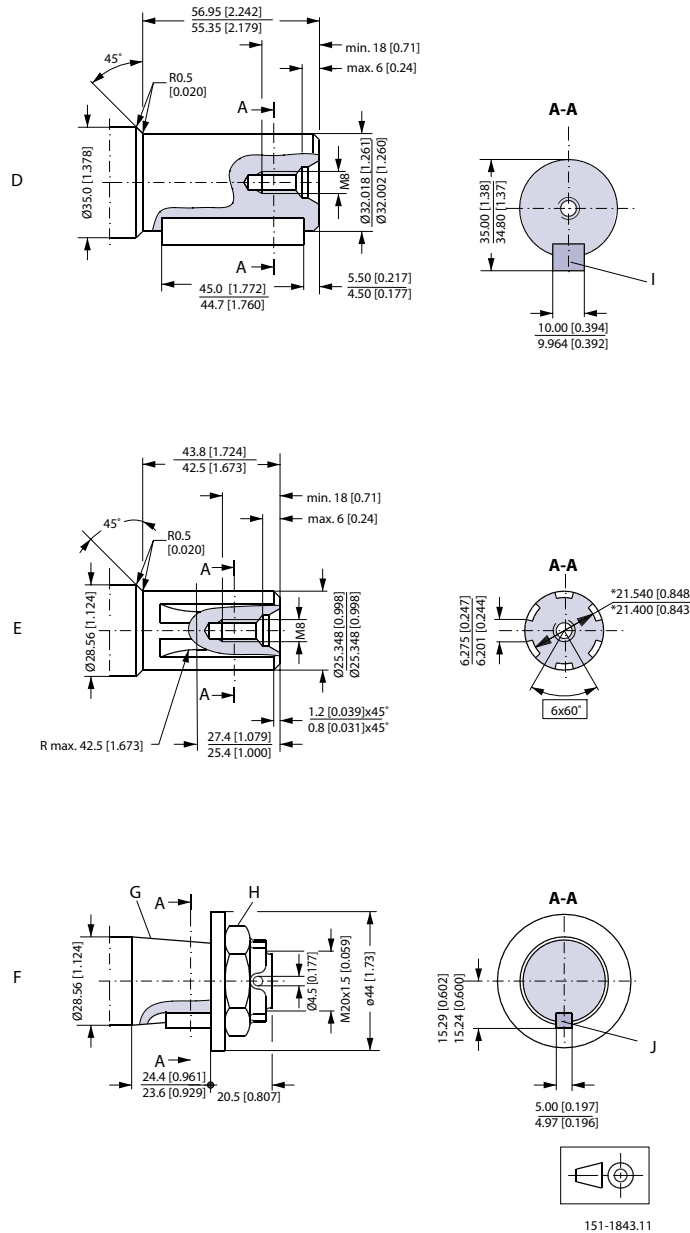

D: Cylindrical shaft 32 mm

G: Taper 1:10

F: Tapered shaft

E: Splined shaft
B.S. 2059 (SAE 6 B)
Straight-sided,
bottom fitting, dep.

H: DIN 937
NV 30
Tightening torque:
100 ± 10 N·m [885 ± 88.50 lbf·in]

I: Parallel key
A10 8 45
DIN 6885

Fit 2
Nom. size 1 in
* Deviates from BS 2059 (SAE 6B)

J: Parallel key
B5 5 14
DIN 6885

Port Thread Versions

Port Thread Versions

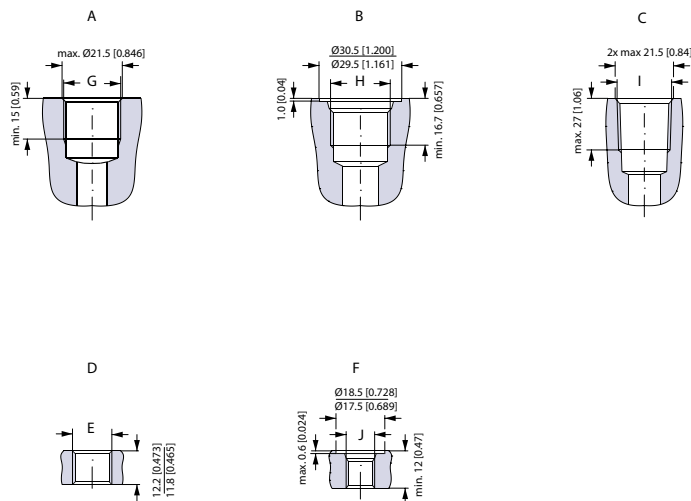

151-1844.11

A: G main ports

G: ISO 228/1 - G1/2

D: G drain port

E: ISO 228/1 - G1/4

B: UNF main ports

H: 7/8 - 14 UNF
O-ring boss port

F: UNF drain port

J: 7/16 - 20 UNF
O-ring boss port

C: NPTF main ports

I: 1/2 - 14 NPTF

Manifold Mount

European version

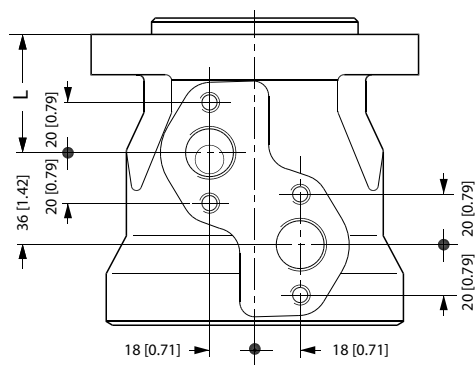

151-2135.10

L: see dimensional drawing for given OMP motor:

[Dimensions - European Version](#) on page 28

[Dimensions - US Version](#) on page 32

[Dimensions - European Version](#) on page 33

[Dimensions - US Version](#) on page 35

[Dimensions - European Version](#) on page 37

Dimensions - European Version
Dimensions

Side port version with 2 hole oval mounting flange (A2-flange).

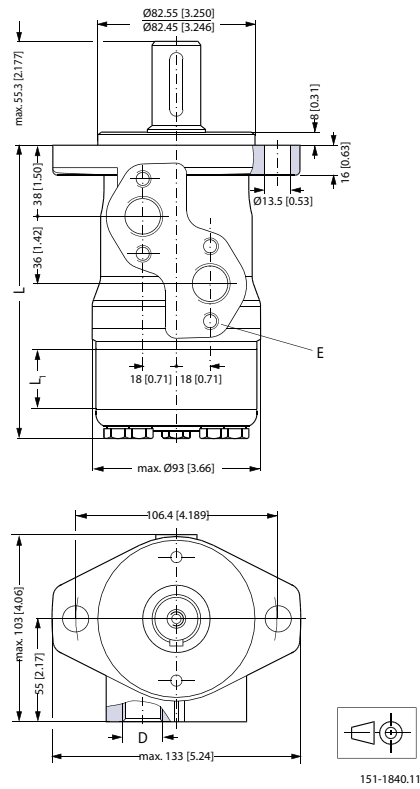

D: G 1/2; 15 mm [0.59 in] deep

E: M8; 13 mm [0.51 in] deep
(4 pcs.)

Type	Max. L mm [in]	L1 mm [in]
OMP 25	130.0 [5.12]	4.1 [0.16]
OMP 32	131.0[5.16]	5.2[0.20]
OMP 40	132.0 [5.20]	6.5 [0.26]
OMP 50	132.0 [5.20]	6.5 [0.26]
OMP 80	136.0 [5.35]	10.4 [0.41]
OMP 100	138.5 [5.45]	13.0 [0.51]
OMP 125	142.0 [5.59]	16.7 [0.66]
OMP 160	146.5 [5.77]	20.8 [0.82]
OMP 200	151.5 [5.96]	26.0 [1.02]
OMP 250	158.0[6.22]	32.5 [1.28]
OMP 315	166.5 [6.56]	40.9 [1.61]
OMP 400	177.6 [6.99]	52.0 [2.05]

Dimensions - European Version

Side port version with 2 hole oval mounting flange (A2-flange). With drain connection.

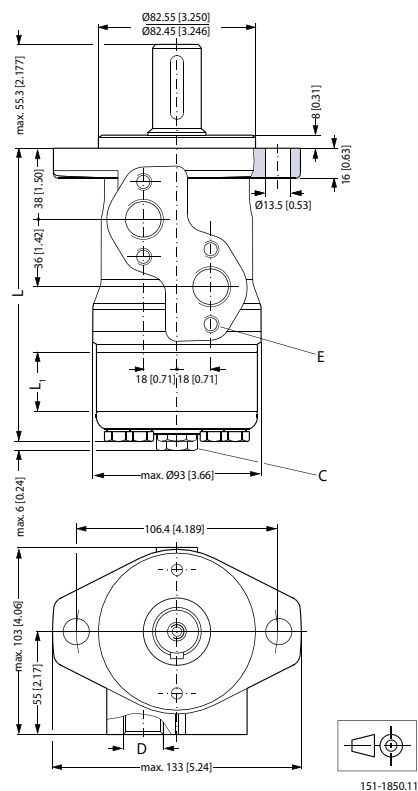

151-1850.11

C: Drain connection

D: G ½; 15 mm [0.59 in] deep

G ¼; 12 mm [0.47 in] deep

E: M8; 13 mm [0.51 in] deep
(4 pcs.)

Type	Max.L mm [in]	L1 mm [in]
OMP 25	130.0 [5.12]	4.1 [0.16]
OMP 32	131.0 [5.16]	5.2 [0.20]
OMP 40	132.0 [5.20]	6.5 [0.26]
OMP 50	132.0 [5.20]	6.5 [0.26]
OMP 80	136.0 [5.35]	10.4 [0.41]
OMP 100	138.5 [5.45]	13.0 [0.51]
OMP 125	142.0 [5.59]	16.7 [0.66]
OMP 160	146.5 [5.77]	20.8 [0.82]
OMP 200	151.5 [5.96]	26.0 [1.02]
OMP 250	158.0 [6.22]	32.5 [1.28]
OMP 315	166.5 [6.56]	40.9 [1.61]
OMP 400	177.6 [6.99]	52.0 [2.05]

Dimensions - European Version

OMP C and OMP N Side port version with 2 hole oval mounting flange (A2-flange).

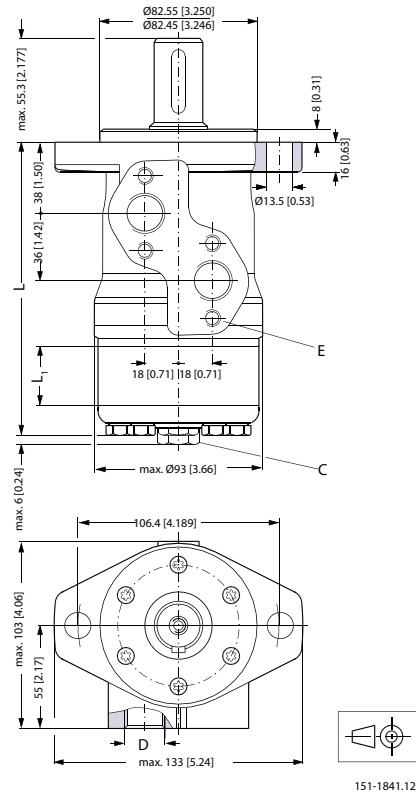

C: Drain connection
G ¼; 12 mm [0.47 in] deep

D: G ½; 15 mm [0.59 in] deep

E: M8; 13 mm [0.51 in] deep
(4 pcs.)

Type	Max. L mm [in]	L1 mm [in]
OMP 50	132.0 [5.20]	6.5 [0.26]
OMP 80	136.0 [5.35]	10.4 [0.41]
OMP 100	138.5 [5.45]	13.0 [0.51]
OMP 125	142.0 [5.59]	16.7 [0.66]
OMP 160	146.5 [5.77]	20.8 [0.82]
OMP 200	151.5 [5.97]	26.0 [1.02]
OMP 250	158.0 [6.22]	32.5 [1.28]
OMP 315	166.5 [6.56]	40.9 [1.61]
OMP 400	177.6 [6.99]	52.0 [2.05]

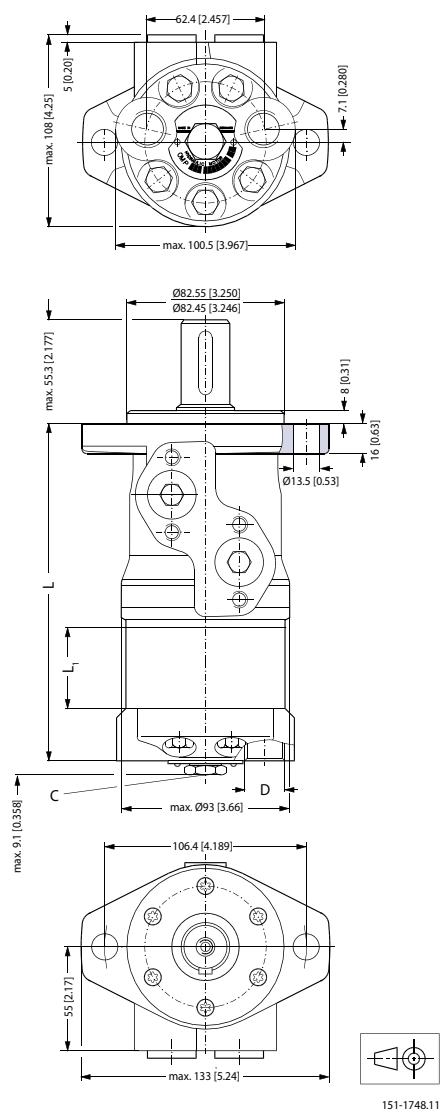
Dimensions - European Version
End port version with 2 hole oval mounting flange (A2-flange).

151-1748.11

C: Drain connection
 G ¼; 12 mm [0.47 in] deep

D: G ½; 15 mm [0.59 in] deep

Type	Max. L mm [in]	L1 mm [in]
OMP 50	146.1 [5.75]	6.5 [0.26]
OMP 80	150.0 [5.91]	10.4 [0.41]
OMP 100	152.7 [6.01]	13.0 [0.51]
OMP 125	156.2 [6.15]	16.7 [0.66]
OMP 160	160.4 [6.32]	20.8 [0.82]
OMP 200	165.6 [6.52]	26.0 [1.02]
OMP 250	172.1 [6.78]	32.5 [1.28]
OMP 315	180.5 [7.11]	40.9 [1.61]
OMP 400	191.6 [7.54]	52.0 [2.05]

Dimensions - US Version
Dimensions

Side port version with 2 hole oval mounting flange (A2-flange).

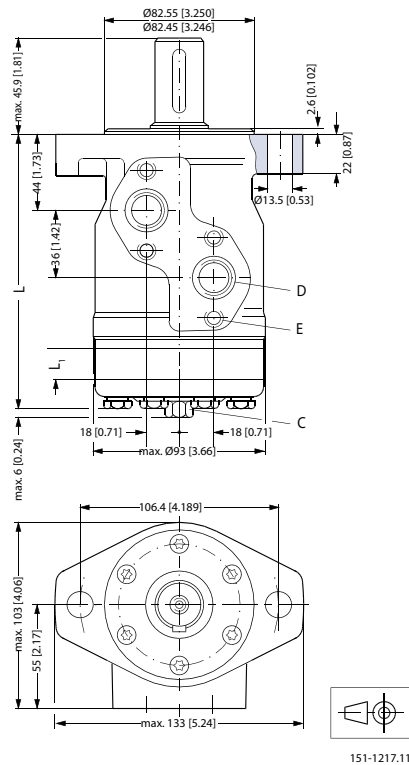

C: Drain connection
G 7/16 UNF;
12 mm [0.47 in] deep

D: G 7/8 - 14 UNF;
16.7 mm [0.66 in] deep

E: M8; 13 mm [0.51 in] deep
(4 pcs.)

Type	Max. L mm [in]	L1 mm [in]
OMP 25	136.0 [5.35]	4.1 [0.16]
OMP 32	137.0 [5.39]	5.2 [0.20]
OMP 40	138.0 [5.43]	6.5 [0.26]
OMP 50	138.0 [5.43]	6.5 [0.26]
OMP 80	142.0 [5.59]	10.4 [0.41]
OMP 100	144.5 [5.69]	13.0 [0.51]
OMP 125	148.0 [5.83]	16.7 [0.66]
OMP 160	152.5 [6.00]	20.8 [0.82]
OMP 200	157.5 [6.20]	26.0 [1.02]
OMP 250	164.0 [6.46]	32.5 [1.28]
OMP 315	172.5 [6.79]	40.9 [1.61]
OMP 400	183.6 [7.23]	52.0 [2.05]

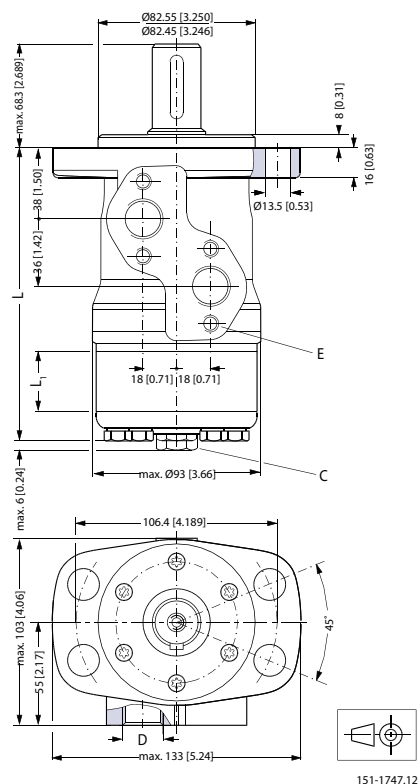
Dimensions - European Version
Dimensions
Side port version with 4 hole oval mounting flange (A4-flange).

151-1747.12

C: Drain connection

G ¼; 12 mm [0.47 in] deep

E: M8; 13 mm [0.51 in] deep

(4 pcs.)

D: G ½; 15 mm [0.59 in] deep

Type	Max. L mm [in]	L1 mm [in]
OMP 50	132.0 [5.20]	6.5 [0.26]
OMP 80	136.0 [5.35]	10.4 [0.41]
OMP 100	138.5 [5.45]	13.0 [0.51]
OMP 125	142.0 [5.59]	16.7 [0.66]
OMP 160	146.5 [5.77]	20.8 [0.82]
OMP 200	151.5 [5.97]	26.0 [1.02]
OMP 250	158.0 [6.22]	32.5 [1.28]
OMP 315	166.5 [6.56]	40.9 [1.61]
OMP 400	177.6 [6.99]	52.0 [2.05]

Dimensions - European Version

End port version with square mounting flange (C-flange).

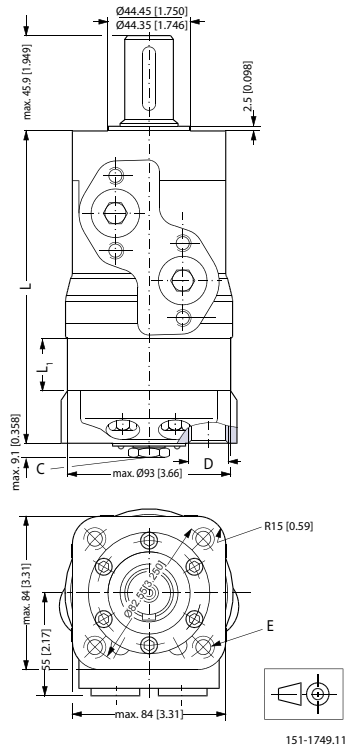

151-1749.11

C: Drain connection
G ¼; 12 mm [0.47 in] deep
(4 pcs.)

D: G ½; 15 mm [0.59 in] deep

E: M10; 15 mm [0.59 in] deep

Type	Max. L mm [in]	L1mm [in]
OMP 50	152.0 [5.98]	6.5 [0.26]
OMP 80	156.0 [6.14]	10.4 [0.41]
OMP 100	158.6 [6.24]	13.0 [0.51]
OMP 125	162.1 [6.38]	16.7 [0.66]
OMP 160	166.4 [6.55]	20.8 [0.82]
OMP 200	171.6 [6.76]	26.0 [1.02]
OMP 250	178.1 [7.01]	32.5 [1.28]
OMP 315	186.5 [7.34]	40.9 [1.61]
OMP 400	197.6 [7.78]	52.0 [2.05]

Dimensions - US Version

Dimensions

Side port version with square mounting flange (C-flange).

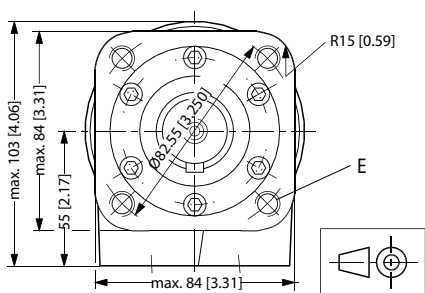
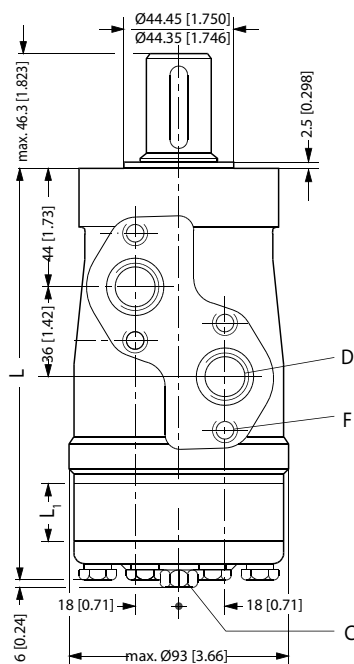

151-1214.11

C: Drain connection
7/16 - 20 UNF;
12 mm [0.47 in] deep

E: 3/8 - 16 UNC;
15 mm [0.59 in] deep
(4 off)

D: 7/8 - 14 UNF;
16.76 mm [0.66 in] deep
or 1/2 - 14 NPTF

F: M8; 13 mm [0.51 in] deep
(4 pcs.)

Type	Max. L mm [in]	L1 mm [in]
OMP 50	132.0 [5.20]	6.5 [0.26]
OMP 80	136.0 [5.35]	10.4 [0.41]
OMP 100	138.5 [5.45]	13.0 [0.51]
OMP 125	142.0 [5.59]	16.7 [0.66]

Technical Information Orbital Motors Type OMP, OMR and OMH

Dimensions - US Version

Type	Max. L mm [in]	L1 mm [in]
OMP 160	146.5 [5.77]	20.8 [0.82]
OMP 200	151.5 [5.97]	26.0 [1.02]
OMP 250	158.0 [6.22]	32.5 [1.28]
OMP 315	166.5 [6.56]	40.9 [1.61]
OMP 400	177.6 [6.99]	52.0 [2.05]

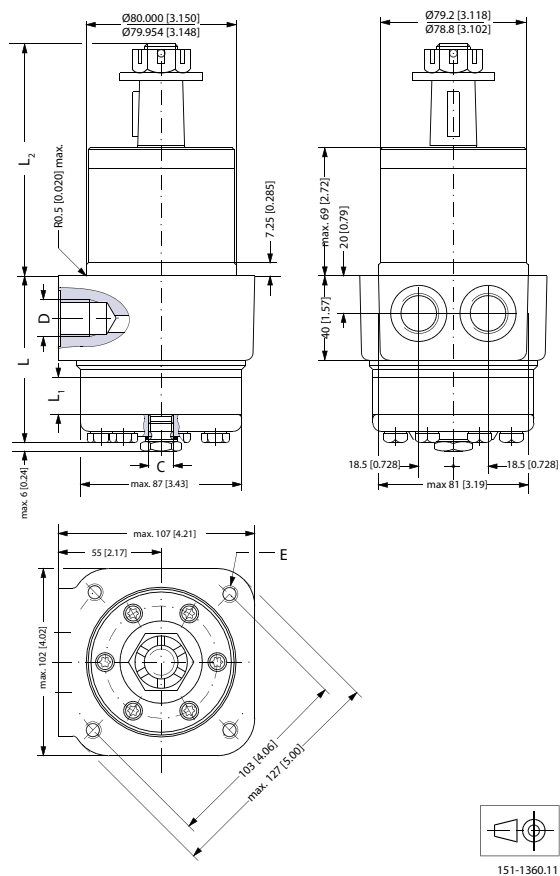
Dimensions - European Version
Dimensions
OMPW and OMPW N wheel motor

C: Drain connection

G $\frac{1}{4}$; 12 mm [0.47 in] deep

E: M10; 20 mm [0.79 in] deep
(4 pcs.)

D: G $\frac{1}{2}$; 15 mm [0.59 in] deep

Output shaft.max.	L2 mm [in]
Cylindrical shaft 25 mm [0.98 in]	max. 115 [4.53]
Tapered shaft 28.56 mm [1.12 in]	max. 117.8 [4.64]

Type	Max. L mm [in]	L1 mm [in]
OMP 50	71.8 [2.83]	6.5 [0.26]
OMP 80.	75.7 [2.98]	10.4 [0.41]
OMP 100	78.3 [3.08]	13.0 [0.51]
OMP 125	81.6 [3.21]	16.7 [0.66]
OMP 160	86.1 [3.39]	20.8 [0.82]
OMP 200	91.3 [3.60]	26.0 [1.02]

Dimensions - European Version

Type	Max. L mm [in]	L1 mm [in]
OMP 250	97.8 [3.85]	32.5 [1.28]
OMP 315	106.2 [4.18]	40.9 [1.61]
OMP 400	117.3 [4.62]	52.0 [2.05]

Technical Information Orbital Motors Type OMP, OMR and OMH
Versions
Versions

Mounting flange	Spigot diameter (front/rear end)	Bolt circle diameter (BC)	Shaft	Port size	EU	US	Side port	End port	Flange port	Std. shaft seal	High pressure shaft seal	Drain connection	Check valve	Main type designation		
2 hole oval flange (A2-flange)	Ø 82.5 mm [3.25 in]	Ø 106.4 mm [4.20 in]	Cyl. 25 mm	G ½	*		*				*	No	No	OMR		
				G ½	*		*				*	Yes	Yes	OMR		
				G ½	*			*			*	Yes	Yes	OMR		
			Cyl. 1 inch				G ½	*		*			*	No	No	OMR
							G ½	*		*			*	Yes	Yes	OMR
							7/8 - 14 UNF		*	*			*	Yes	Yes	OMR
			Splined 1 inch				G ½	*		*			*	No	No	OMR
							G ½	*		*			*	Yes	Yes	OMR
							7/8 - 14 UNF		*	*			*	Yes	Yes	OMR
			Cyl. 32 mm				G ½	*		*			*	Yes	Yes	OMR
Tap. 28.5 mm	G ½	*						*			*	Yes	Yes	OMR		
4 hole oval flange (A4-flange)	Ø 82.5 mm [3.25 in]	Ø 106.4 mm [4.20 in]	Cyl. 25 mm	G ½	*		*			*		Yes	Yes	OMR		
				Cyl. 32 mm	G ½	*		*			*		Yes	Yes	OMR	
				Cyl. 1¼ in	7/8 - 14 UNF		*	*			*		Yes	Yes	OMR	
Square flange (C-flange)	Ø 44.4 mm [1.75 in]	Ø 82.5 mm [3.25 in]	Cyl. 25 mm	G ½	*			*		*		Yes	Yes	OMR		
				Cyl. 1 in	7/8 - 14 UNF		*	*			*		Yes	Yes	OMR	
OMR motors with corrosion resistant parts																
2 hole oval flange (A2-flange)	Ø 82.5 mm [3.25 in]	Ø 106.4 mm [4.20 in]	Cyl. 25 mm	G ½	*		*			*		Yes	Yes	OMR C		
OMR motors with needle bearings																
2 hole oval flange (A2-flange)	Ø 82.5 mm [3.25 in]	Ø 106.4 mm [4.20 in]	Cyl. 25 mm	G ½	*		*			*		Yes	Yes	OMR N		
Wheel	Ø 82.5 mm [3.25 in]	Ø 147.6 mm [5.81 in]	Tap. 35 mm	G ½	*				*	*		Yes	Yes	OMRW N		
				Tap. 1¼ in	7/8 - 14 UNF		*	*		*	*		Yes	Yes	OMRW N	
OMR motors with integrated brake																
2 hole oval flange (A2-flange)	Ø 82.5 mm [3.25 in]	Ø 106.4 mm [4.20 in]	Cyl. 25 mm	G ½	*		*			*		Yes	Yes	OMR F		
OMR motors with integrated brake and needle bearings																
2 hole oval flange (A2-flange)	Ø 82.5 mm [3.25 in]	Ø 106.4 mm [4.20 in]	Cyl. 1 in	7/8 - 14 UNF		*	*			*		Yes	Yes	OMR NF		
Wheel	Ø 82.5 mm [3.25 in]	Ø 147.6 mm [5.81 in]	Tap. 35 mm	G ½	*				*	*		Yes	Yes	OMRW NF		

* Version is available.

Versions

Features available (options)

Low leakage (low speed valve) Reverse rotation

Speed sensor Painted

Viton shaft seal