

HYDRAULIC GEAR
PUMPS AND
MOTORS

INDEX

Section	Page
FEATURES.....	3
GENERAL DATA PUMPS AND MOTORS	6
PUMPS PERFORMANCE CURVES	8
MOTORS PERFORMANCE CURVES.....	20
SINGLE UNITS DIMENSIONS	32
MULTIPLE PUMPS	37
MULTIPLE PUMPS DIMENSION	43
VERSIONS (OUTBOARD BEARING FOR SHAFTS)	47
DRIVE SHAFTS	52
MOUNTING FLANGES	58
PORTS	69
CHANGING ROTATION	75
INSTRUCTIONS.....	76
VALVES AVAILABILITY.....	77
HOW TO ORDER.....	78

Replaces: 01/10.03

02/07.2006

FEATURES

“POLARIS” more than fifty years of Casappa experience in design and production of hydraulic components, characterized by large investments in research and development in order to propose new and personalized solutions to the market.

Our use of CAD 3D in the development of this generation permit us the 3D modelling and the virtual simulation of the behaviour of the components inserted in the hydraulic circuit. This means that the process will take less time and the quality of the products is better.

Polaris pumps and motors are basically composed of a gear housing in aluminium alloy, two gear wheels supported by sleeve bearings and two end plates, the front and the rear cover, either in aluminium or in cast iron with excellent mechanical characteristics.

Our success is based largely on the quality of our product. This guaranties the consistencies of the efficiencies and low level of noise emission during the life of our products.

DISPLACEMENTS

From 0.07 in³/rev (1,07 cm³/rev)
To 5.56 in³/rev (91,10 cm³/rev)

PRESSURE

Max. Continuous 3770 psi (260 bar)
Max. Intermittent 4060 psi (280 bar)
Max. Peak 4350 psi (300 bar)

MAX. SPEED

Max. 4000 min⁻¹

- Group 1, 2 and 3 with displacements from 0.07 in³/rev (1,07 cm³/rev) to 5.56 in³/rev (91.10 cm³/rev).
- Drive shafts, mounting flanges and ports according to the international standards.
- Combination of multiple pumps in standard version, common inlet and separated stages.
- Integrated outboard bearings for heavy duty application.
- Many types of built-in valves.

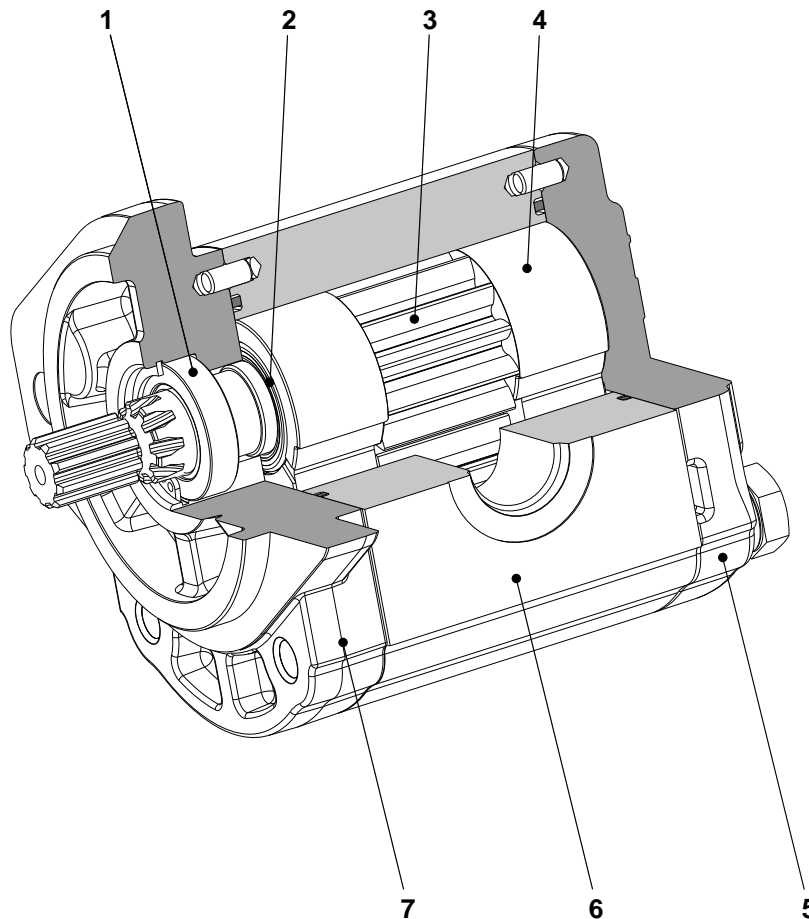

1	Shaft seal
2	Seal
3	Gear
4	Thrust plate
5	Rear cover
6	Body
7	Mounting flange

02/07.2006

FEATURES

Construction	External gear type pumps and motors
Mounting	EUROPEAN - SAE - GERMAN standard flanges
Line connections	Screw and flange
Direction of rotation (looking at the drive shaft)	Anti-clock (S) - clockwise (D) - reversible external drain (L - R) reversible internal drain (B)
Inlet pressure range for pumps	10 ÷ 44 psi - [0,7 ÷ 3 bar (abs.)]
Max back pressure for single rotation motors and reversible internal drain motors	p_1 (continuous) max 73 psi (5 bar)
	p_2 (for 20 s) max 116 psi (8 bar)
	p_3 (for 8 s) max 218 psi (15 bar)
Max drain line pressure on reversible rotation motors	73 psi (5 bar)
Max back pressure on the series motors (reversible motors external drain)	< p_1 (max continuous pressure) < 2175 psi (<150 bar)
Fluid temperature range	See table (1)
Fluid	Mineral oil based hydraulic fluids to ISO/DIN. For other fluids please consult our technical sales department.
Viscosity range	From 60 to 456 SSU [12 to 100 mm ² /s (cSt)] recommended
	Up to 3410 SSU [750 mm ² /s (cSt)] permitted
Filtering requirement	See table (2) page 5

Replaces: 01/10.03

Tab. 1 ●

Type	Fluid composition	Max pressure psi - (bar)	Max speed min ⁻¹	Temperature °F - (°C)			Seals (●)	Special shaft seals (◆)
				Min	Max continuous	Max peak		
ISO/DIN	Mineral oil based hydraulic fluid to ISO/DIN	See page 6	See page 6	-13 (-25)	176 (80)	212 (100)	N	D - H - C
				-13 (-25)	230 (110)	257 (125)	V	D

(●) **N**= Buna N (standard) - **V**= Viton

(◆) SHAFT SEALS MAX PRESSURE AND MOUNTING SCHEME

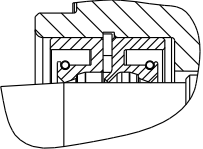
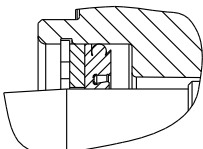
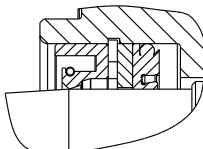
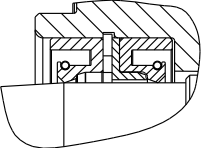
	D	H	C
	Standard shaft seals with wiper seal	High pressure special shaft seal	High pressure special shaft seal with wiper seal
	Max 44 psi (3 bar)	Max 363 psi (25 bar) #	Max 363 psi (25 bar) #
Single rotation pumps	DCAT_033_037 	DCAT_033_039 	DCAT_033_036 
Single rotation motors Reversible rotation pumps and motors	DCAT_033_038 		

● 02/07.2006

Pressure could change in connection with shaft speed rotation. For more information please consult out technical sales department.

FEATURES

FILTRATION

Tab. 2



Casappa recommends to use its own production filters:



Replaces: 02/07.2006

Working pressure psi (bar)	$\Delta p < 2030$ $\Delta p < (140)$	$2030 < \Delta p < 3045$ $(140) < \Delta p < (210)$	$\Delta p > 3045$ $\Delta p > (210)$
Contamination class NAS 1638	10	9	8
Contamination class ISO 4406:1999	21/19/16	20/18/15	19/17/14
Achieved with filter $\beta_{10}(c) \geq 75$ according to ISO 16889	-	10 μm	10 μm
Achieved with filter $\beta_{25}(c) \geq 200$ according to ISO 16889	25 μm	-	-

GENERAL NOTES

Available with different inlet and outlet ports.
For more information please consult our technical sales department.

DEFINITION OF ROTATION DIRECTION LOOKING AT THE DRIVE SHAFT

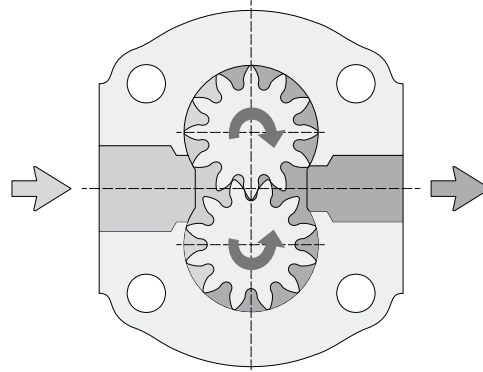
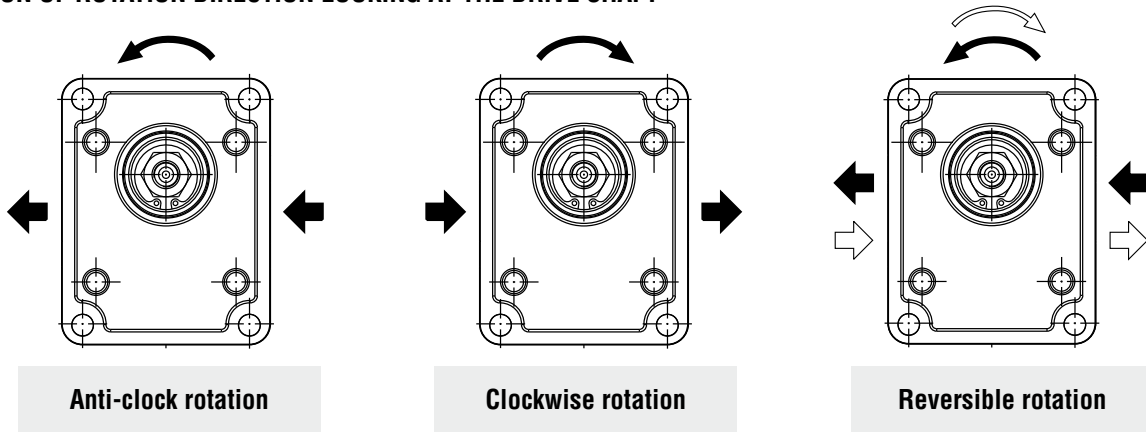

03/02.2012

PRESSURE DEFINITION

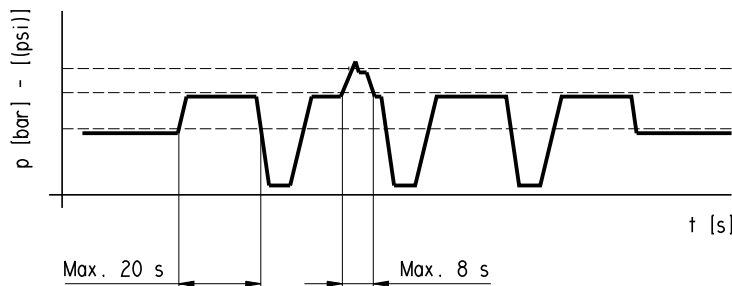

p_1 Max. continuous pressure
 p_2 Max. intermittent pressure
 p_3 Max. peak pressure

GENERAL DATA PUMPS AND MOTORS

Series	Pump type PLP Motor type PLM	Displacement in ³ /rev (cm ³ /rev)	Max. pressure			Max. speed	Min. speed min ⁻¹
			p ₁	p ₂	p ₃		
			psi (bar)				
POLARIS 10	PL. 10•1	0.07 (1,07)	3770 (260)	4060 (280)	4205 (290)	4000	650
	PL. 10•1,5	0.10 (1,6)	3770 (260)	4060 (280)	4205 (290)	4000	650
	PL. 10•2	0.13 (2,13)	3770 (260)	4060 (280)	4205 (290)	4000	650
	PL. 10•2,5	0.16 (2,67)	3770 (260)	4060 (280)	4205 (290)	4000	650
	PL. 10•3,15	0.20 (3,34)	3770 (260)	4060 (280)	4205 (290)	4000	650
	PL. 10•4	0.26 (4,27)	3625 (250)	3915 (270)	4060 (280)	4000	650
	PL. 10•5	0.33 (5,34)	3625 (250)	3915 (270)	4060 (280)	4000	650
	PL. 10•5,8	0.38 (6,20)	3335 (230)	3625 (250)	3770 (260)	3500	650
	PL. 10•6,3	0.41 (6,67)	3335 (230)	3625 (250)	3770 (260)	3500	650
	PL. 10•8	0.52 (8,51)	2610 (180)	2900 (200)	3045 (210)	3500	650
PL. 10•10	0.65 (10,67)	2030 (140)	2320 (160)	2465 (170)	3500	650	
POLARIS 20	PL. 20•4	0.30 (4,95)	3625 (250)	4060 (280)	4350 (300)	4000	600
	PL. 20•6,3	0.40 (6,61)	3625 (250)	4060 (280)	4350 (300)	4000	600
	PL. 20•7,2	0,44 (7,29)	3625 (250)	4060 (280)	4350 (300)	4000	600
	PL. 20•8	0.50 (8,26)	3625 (250)	4060 (280)	4350 (300)	3500	600
	PL. 20•9	0.56 (9,17)	3625 (250)	4060 (280)	4350 (300)	3500	600
	PL. 20•10,5	0.66 (10,9)	3625 (250)	4060 (280)	4350 (300)	3500	600
	PL. 20•11,2	0.69 (11,23)	3625 (250)	4060 (280)	4350 (300)	3500	600
	PL. 20•14	0.89 (14,53)	3625 (250)	4060 (280)	4350 (300)	3500	500
	PL. 20•16	1.03 (16,85)	3625 (250)	4060 (280)	4350 (300)	3000	500
	PL. 20•19	1.16 (19,09)	2900 (200)	3190 (220)	3480 (240)	3000	500
	PL. 20•20	1.29 (21,14)	2900 (200)	3190 (220)	3480 (240)	3000	500
	PL. 20•24,5	1.52 (24,84)	2465 (170)	2755 (190)	3045 (210)	2500	500
	PL. 20•25	1.61 (26,42)	2465 (170)	2755 (190)	3045 (210)	2500	500
	PL. 20•27,8	1.72 (28,21)	1885 (130)	2175 (150)	2465 (170)	2000	500
	PL. 20•31,5	2.01 (33,03)	1885 (130)	2175 (150)	2465 (170)	2000	500
POLARIS 30	PL. 30•22	1.34 (21,99)	3625 (250)	3915 (270)	4060 (280)	3000	350
	PL. 30•27	1.63 (26,70)	3625 (250)	3915 (270)	4060 (280)	3000	350
	PL. 30•34	2.11 (34,55)	3480 (240)	3770 (260)	3915 (270)	3000	350
	PL. 30•38	2.40 (39,27)	3480 (240)	3770 (260)	3915 (270)	3000	350
	PL. 30•43	2.68 (43,98)	3335 (230)	3625 (250)	3770 (260)	3000	350
	PL. 30•51	3.16 (51,83)	3045 (210)	3335 (230)	3480 (240)	2500	350
	PL. 30•61	3.74 (61,26)	2755 (190)	3045 (210)	3190 (220)	2500	350
	PL. 30•73	4.50 (73,82)	2465 (170)	2755 (190)	2900 (200)	2500	350
	PL. 30•82	4.98 (81,68)	2320 (160)	2465 (170)	2610 (180)	2200	350
PL. 30•90	5.56 (91,10)	2175 (150)	2320 (160)	2465 (170)	2200	350	

 p₁= Max. continuous pressure

 p₂= Max. intermittent pressure

 p₃= Max. peak pressure

The values in the table refer to unidirectional pumps and motors. Reversible pumps and motors max pressures are 15% lower than those shown in table. For different working conditions please consult our sales department.

GENERAL DATA PUMPS AND MOTORS

Replaces: 01/10.03

Q	US gpm (l/min)	Flow
M	lbf in (Nm)	Torque
P	HP (kW)	Power
V	in ³ /rev (cm ³ /rev)	Displacement
n	min ⁻¹	Speed
Δp	psi (bar)	Pressure

Efficiencies

		Pumps	Motor
$\eta_v = \eta_v(V, \Delta p, n)$	Volumetric efficiency	($\approx 0,97$)	($\approx 0,96$)
$\eta_{hm} = \eta_{hm}(V, \Delta p, n)$	Hydro-mechanical efficiency	($\approx 0,88$)	($\approx 0,85$)
$\eta_t = \eta_v \cdot \eta_{hm}$	Overall efficiency	($\approx 0,85$)	($\approx 0,82$)

Design calculations for pump ○

$$Q = Q_{\text{theor.}} \cdot \eta_v$$

$$Q_{\text{theor.}} = \frac{V \text{ (cm}^3\text{/rev)} \cdot n \text{ (min}^{-1}\text{)}}{1000} \quad [\text{l/min}]$$

$$M = \frac{M_{\text{theor.}}}{\eta_{hm}} \quad [\text{Nm}]$$

$$M_{\text{theor.}} = \frac{\Delta p \text{ (bar)} \cdot V \text{ (cm}^3\text{/rev)}}{62,83}$$

$$P_{\text{IN}} = \frac{P_{\text{OUT}}}{\eta_t} \quad [\text{kW}]$$

$$P_{\text{OUT}} = \frac{\Delta p \text{ (bar)} \cdot Q \text{ (l/min)}}{600}$$

Design calculations for motor ○

$$Q = \frac{Q_{\text{theor.}}}{\eta_v} \quad [\text{l/min}]$$

$$Q_{\text{theor.}} = \frac{V \text{ (cm}^3\text{/rev)} \cdot n \text{ (min}^{-1}\text{)}}{1000}$$

$$M = M_{\text{theor.}} \cdot \eta_{hm} \quad [\text{Nm}]$$

$$M_{\text{theor.}} = \frac{\Delta p \text{ (bar)} \cdot V \text{ (cm}^3\text{/rev)}}{62,83}$$

$$P_{\text{IN}} = \frac{\Delta p \text{ (bar)} \cdot Q \text{ (l/min)}}{600} \quad [\text{kW}]$$

$$P_{\text{OUT}} = P_{\text{IN}} \cdot \eta_t$$

○ 03/02.2012

Note: Diagrams providing approximate selection data will be found on subsequent pages.

PLP 10

POLARIS 10 GEAR PUMPS PERFORMANCE CURVES

PLP 10

Each curve has been obtained at 122 °F (50°C), using oil with viscosity 168 SSU (36 cSt) at 104 °F (40°C) and at these pressures.

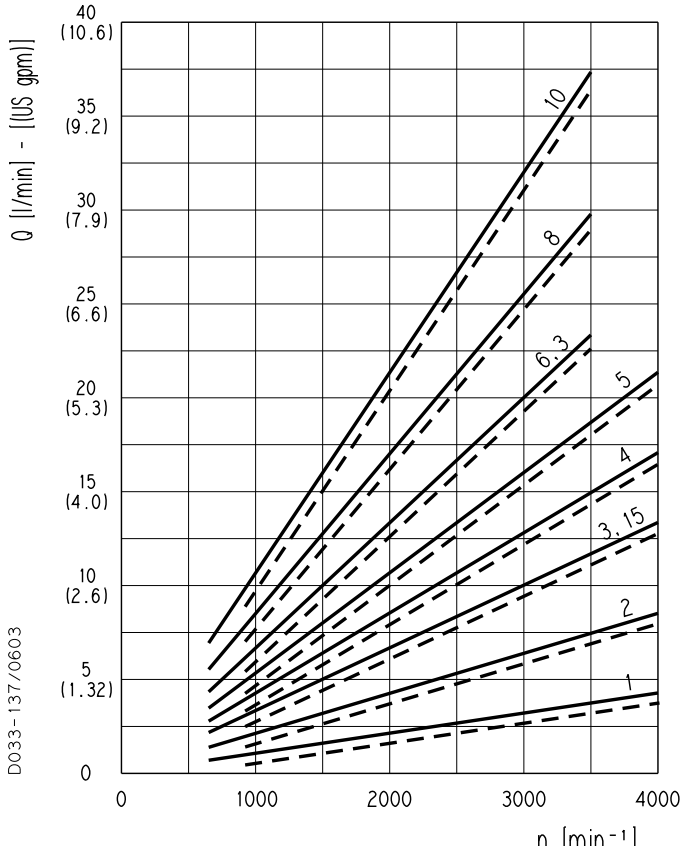

PLP 10•1	—	290 psi (20 bar)
	- -	3770 psi (260 bar)
PLP 10•2	—	290 psi (20 bar)
	- -	3770 psi (260 bar)
PLP 10•3,15	—	290 psi (20 bar)
	- -	3770 psi (260 bar)
PLP 10•4	—	290 psi (20 bar)
	- -	3625 psi (250 bar)
PLP 10•5	—	290 psi (20 bar)
	- -	3625 psi (250 bar)
PLP 10•6,3	—	290 psi (20 bar)
	- -	3335 psi (230 bar)
PLP 10•8	—	290 psi (20 bar)
	- -	2610 psi (180 bar)
PLP 10•10	—	290 psi (20 bar)
	- -	2030 psi (140 bar)

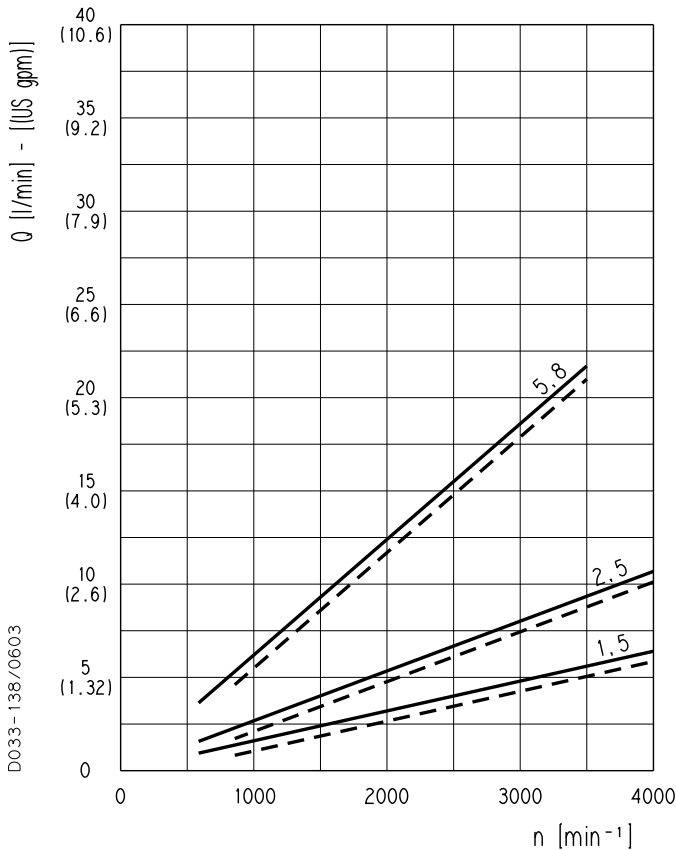

PLP 10•1,5	—	290 psi (20 bar)
	- -	3770 psi (260 bar)
PLP 10•2,5	—	290 psi (20 bar)
	- -	3770 psi (260 bar)
PLP 10•5,8	—	290 psi (20 bar)
	- -	3335 psi (230 bar)

01/10.03

PLP 10

POLARIS 10 GEAR PUMPS PERFORMANCE CURVES

PLP 10•1

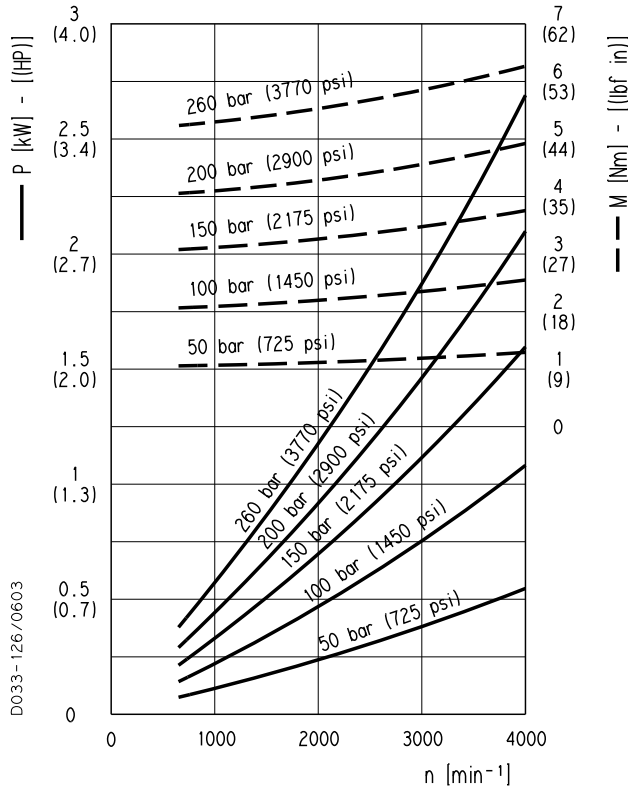

PLP 10•1,5

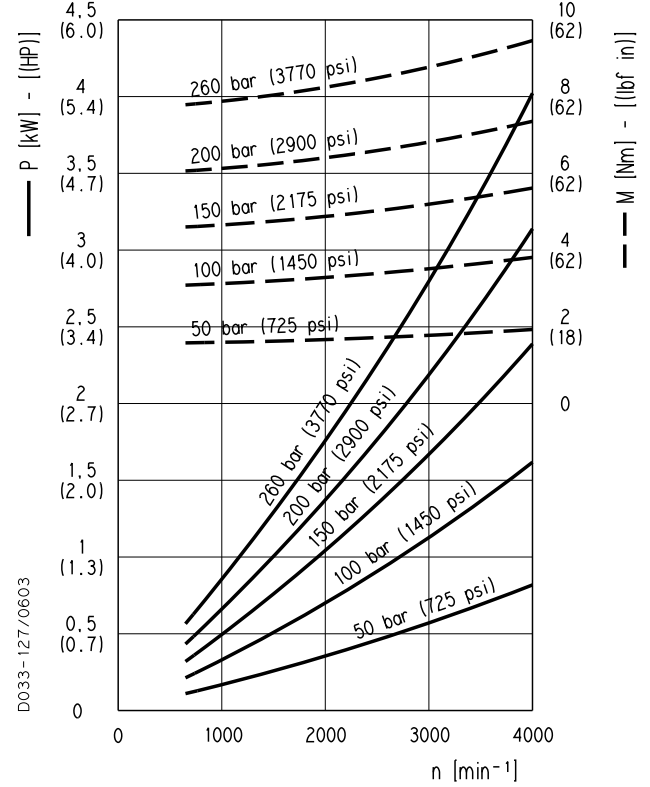

PLP 10•2

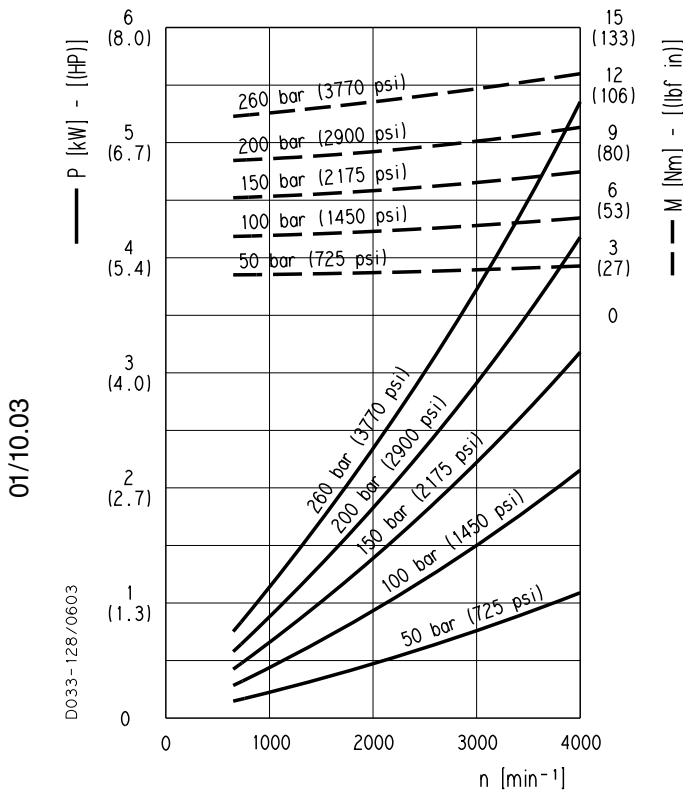

PLP 10•2,5

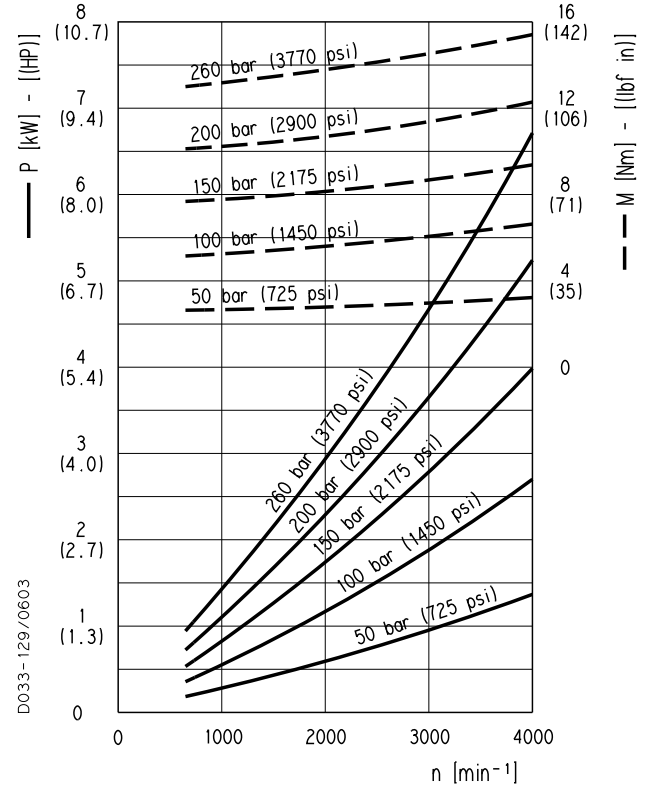

01/10.03

PLP 10

POLARIS 10 GEAR PUMPS PERFORMANCE CURVES

PLP 10•3,15

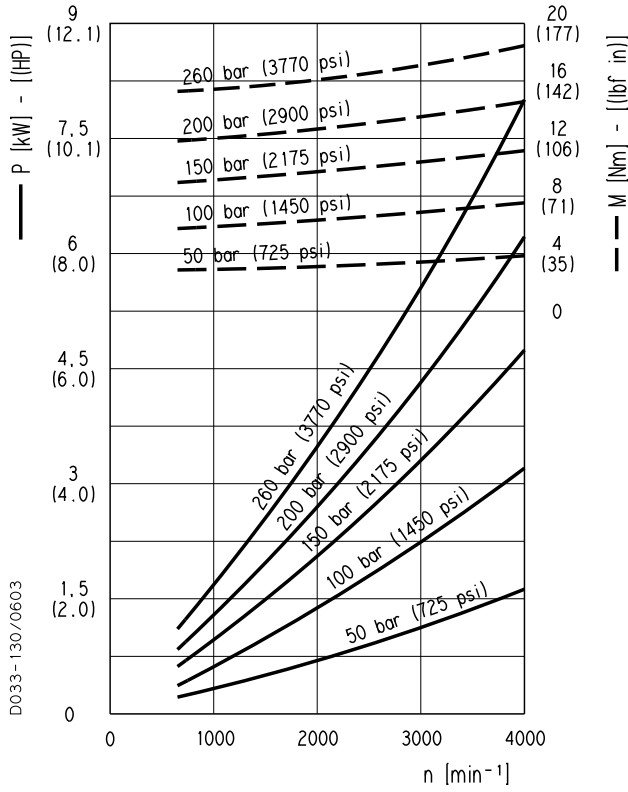

PLP 10•4

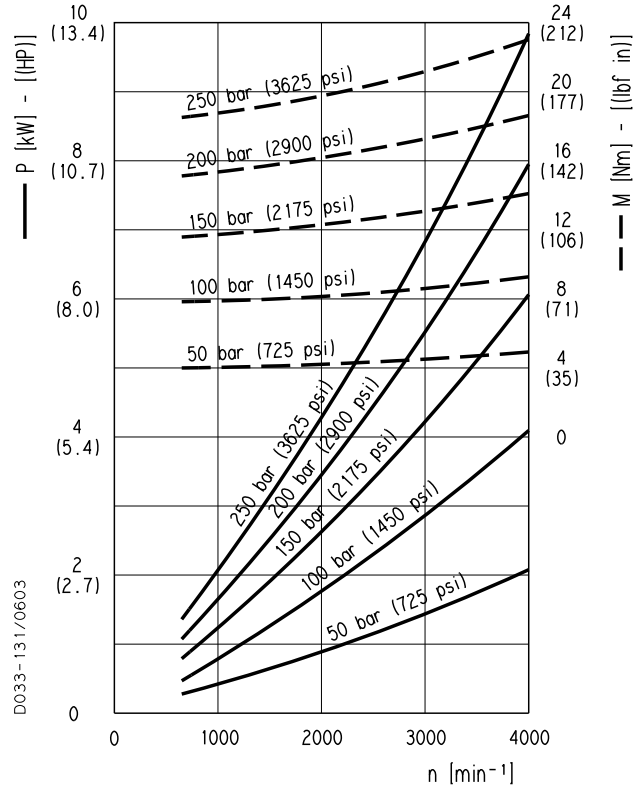

PLP 10•5

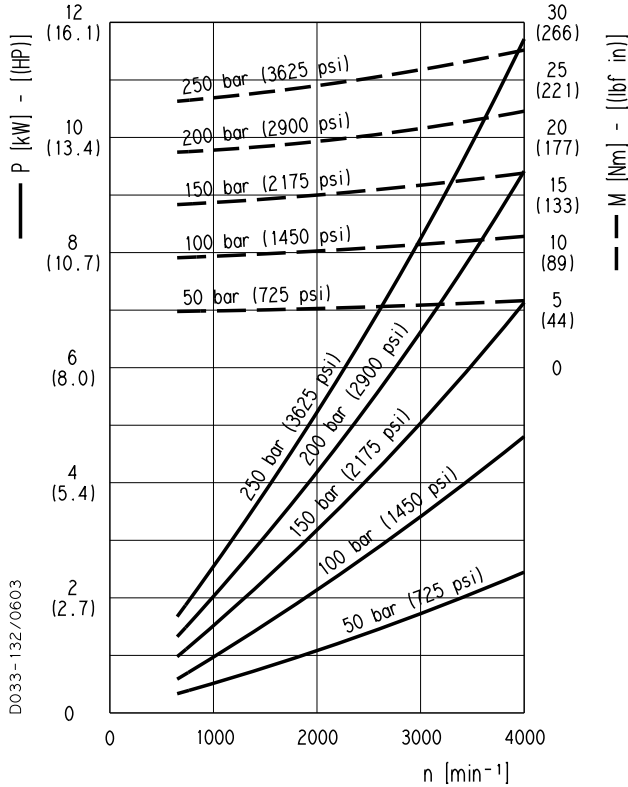

PLP 10•5,8

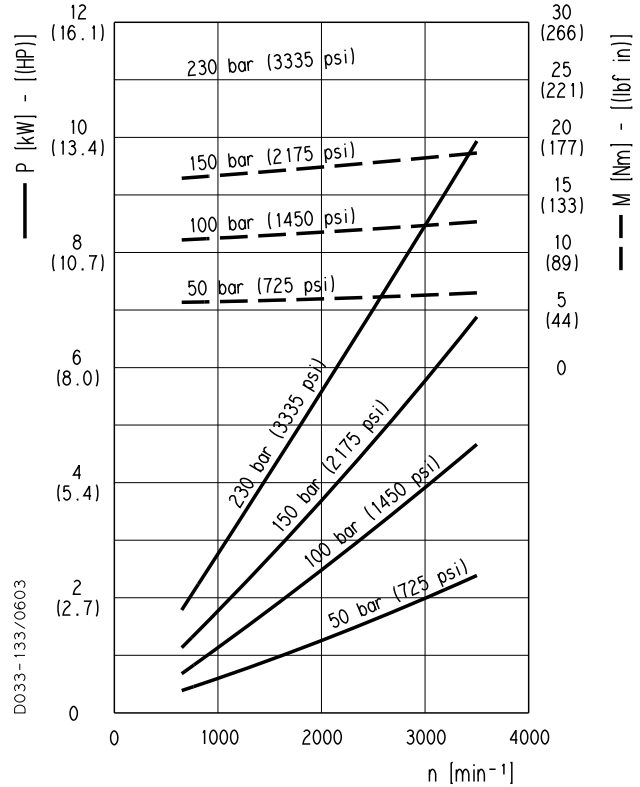

01/10.03

PLP 10

POLARIS 10 GEAR PUMPS PERFORMANCE CURVES

PLP 10•6,3

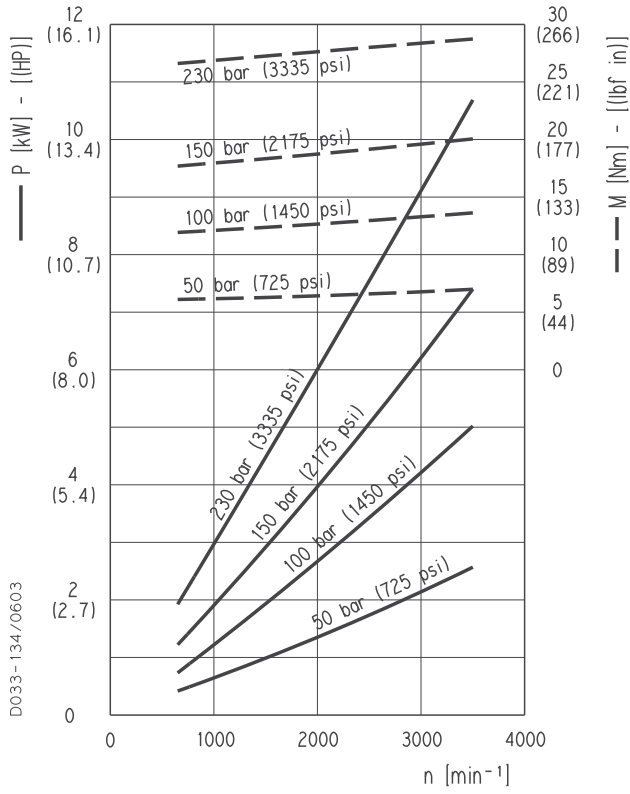

PLP 10•8

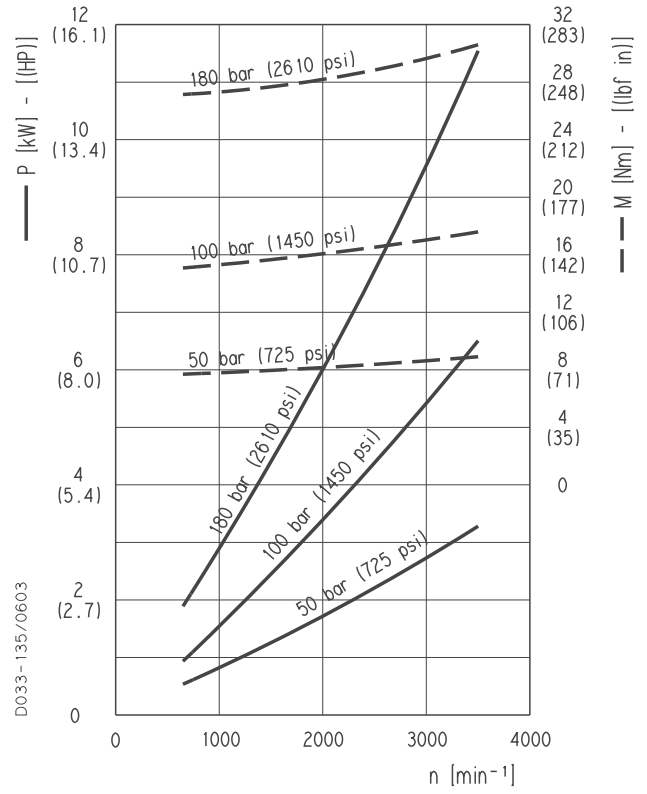

PLP 10•10

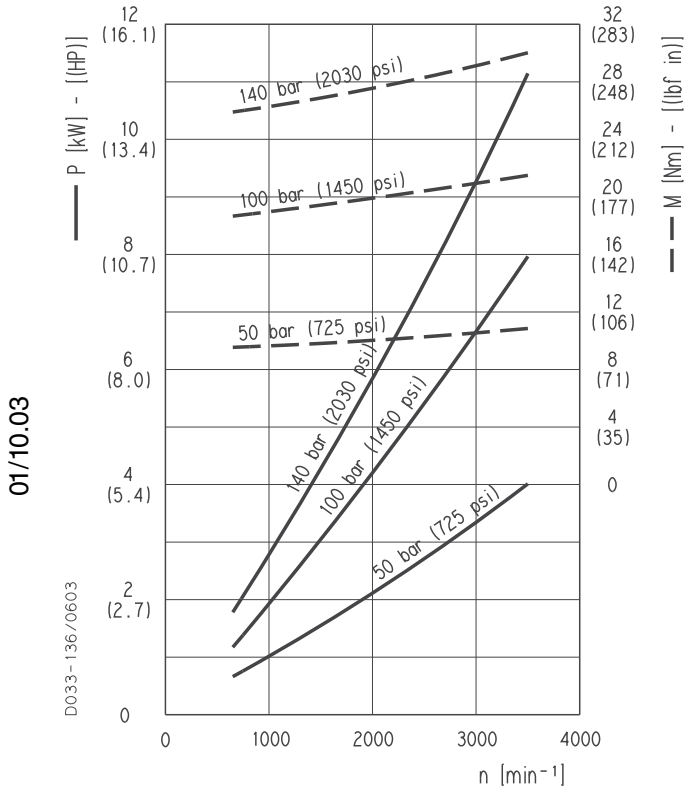

PLP 20

POLARIS 20 GEAR PUMPS PERFORMANCE CURVES

Each curve has been obtained at 122 °F (50°C), using oil with viscosity 168 SSU (36 cSt) at 104 °F (40°C) and at these pressures.

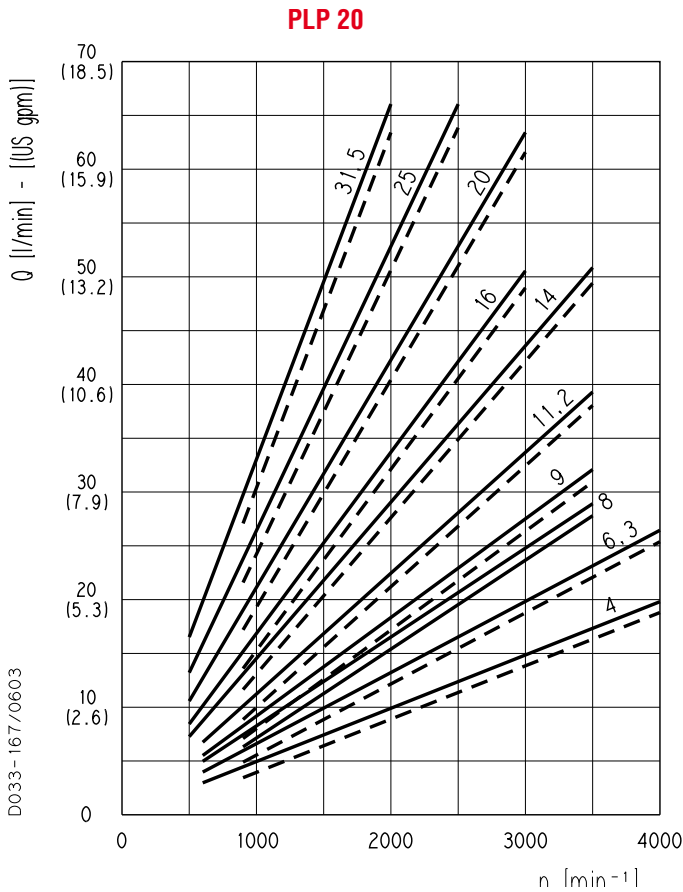

PLP 20•4	—	290 psi (20 bar)
	- -	3625 psi (250 bar)
PLP 20•6,3	—	290 psi (20 bar)
	- -	3625 psi (250 bar)
PLP 20•8	—	290 psi (20 bar)
	- -	3625 psi (250 bar)
PLP 20•9	—	290 psi (20 bar)
	- -	3625 psi (250 bar)
PLP 20•11,2	—	290 psi (20 bar)
	- -	3625 psi (250 bar)
PLP 20•14	—	290 psi (20 bar)
	- -	3625 psi (250 bar)
PLP 20•16	—	290 psi (20 bar)
	- -	3625 psi (250 bar)
PLP 20•20	—	290 psi (20 bar)
	- -	2900 psi (200 bar)
PLP 20•25	—	290 psi (20 bar)
	- -	2465 psi (170 bar)
PLP 20•31,5	—	290 psi (20 bar)
	- -	1885 psi (130 bar)

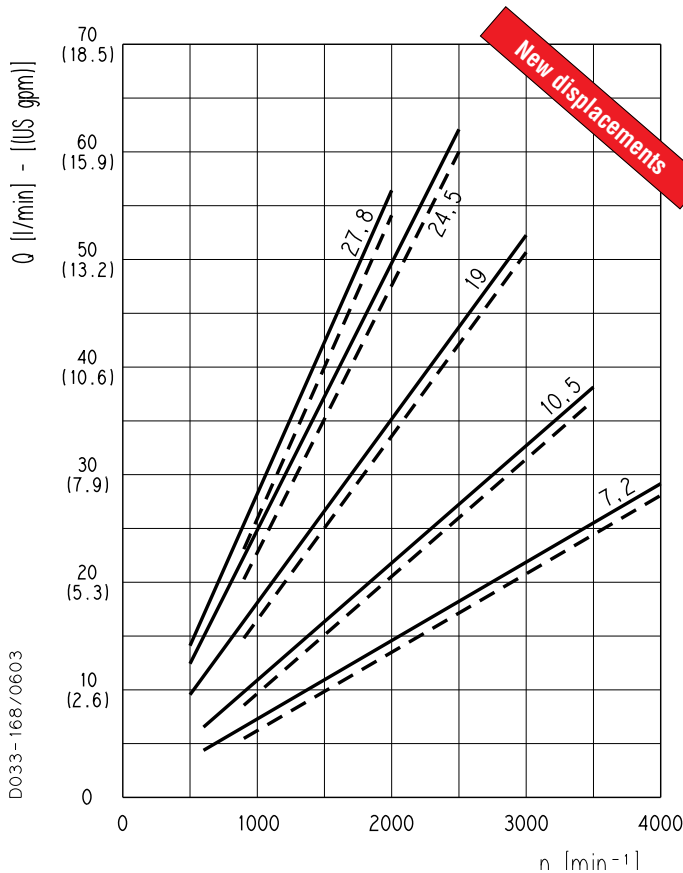

PLP 20•7,2	—	290 psi (20 bar)
	- -	3625 psi (250 bar)
PLP 20•10,5	—	290 psi (20 bar)
	- -	3625 psi (250 bar)
PLP 20•19	—	290 psi (20 bar)
	- -	2900 psi (200 bar)
PLP 20•24,5	—	290 psi (20 bar)
	- -	2465 psi (170 bar)
PLP 20•27,8	—	290 psi (20 bar)
	- -	1885 psi (130 bar)

01/10.03

PLP 20

POLARIS 20 GEAR PUMPS PERFORMANCE CURVES

PLP 20•4

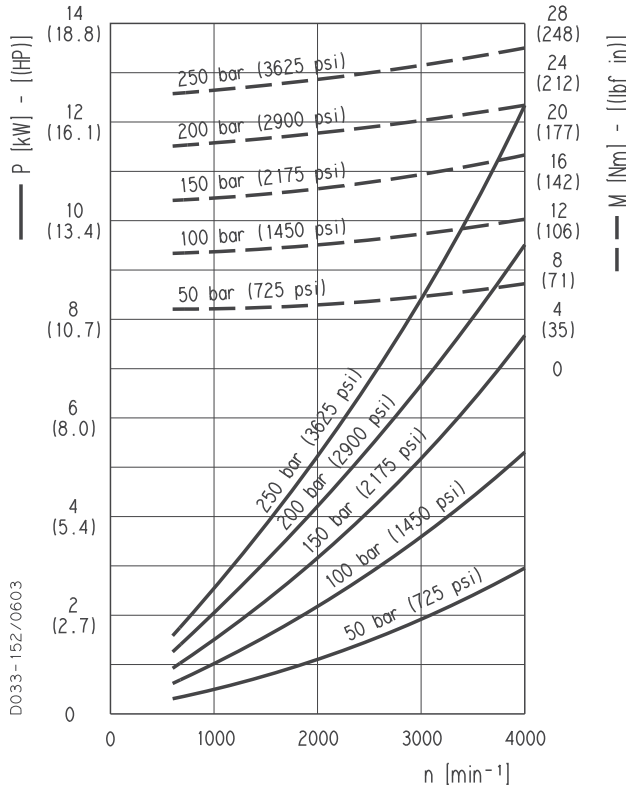

PLP 20•6,3

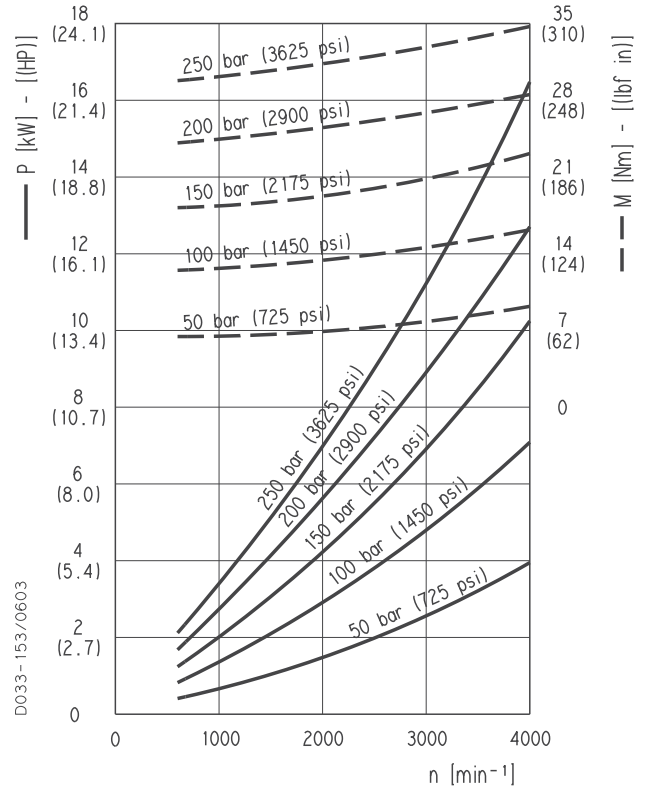

PLP 20•7,2

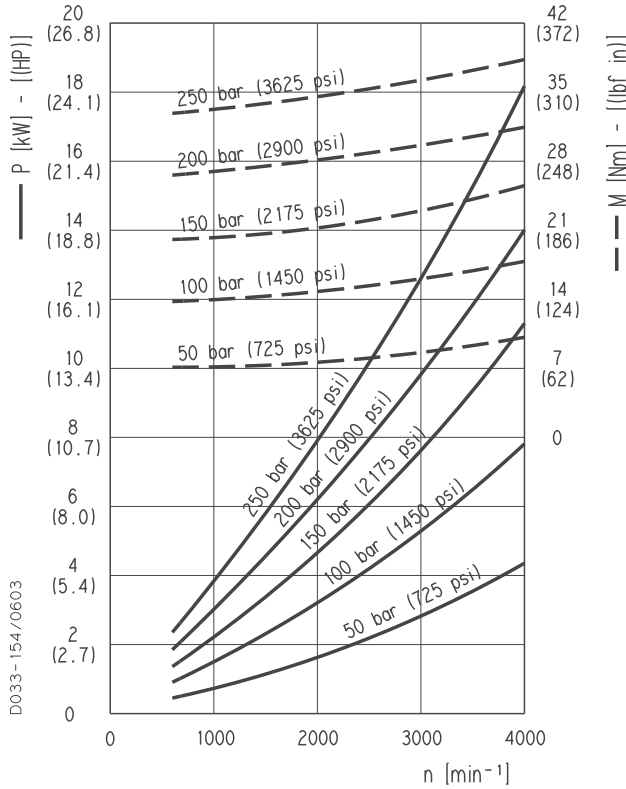

PLP 20•8

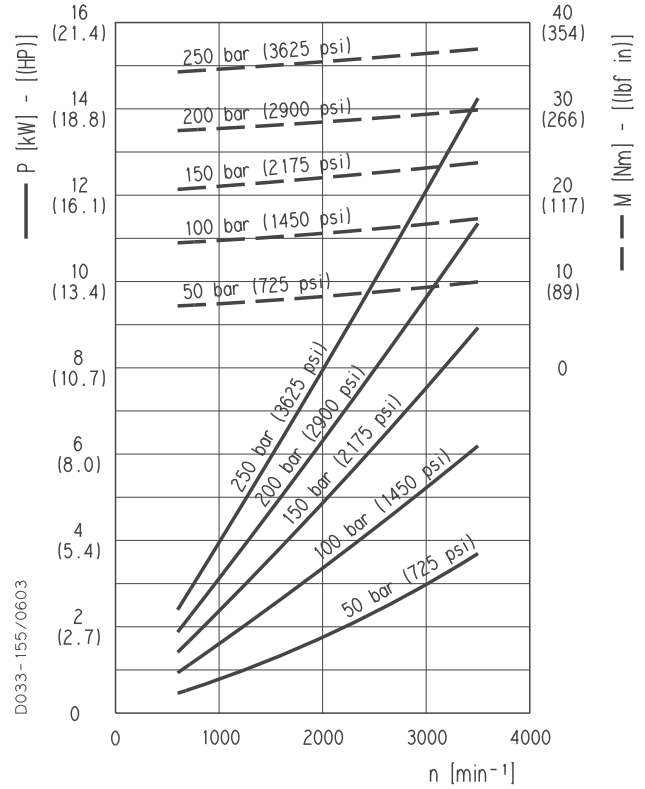

01/10.03

D033-154/0603

D033-155/0603

PLP 20

POLARIS 20 GEAR PUMPS PERFORMANCE CURVES

PLP 20•9

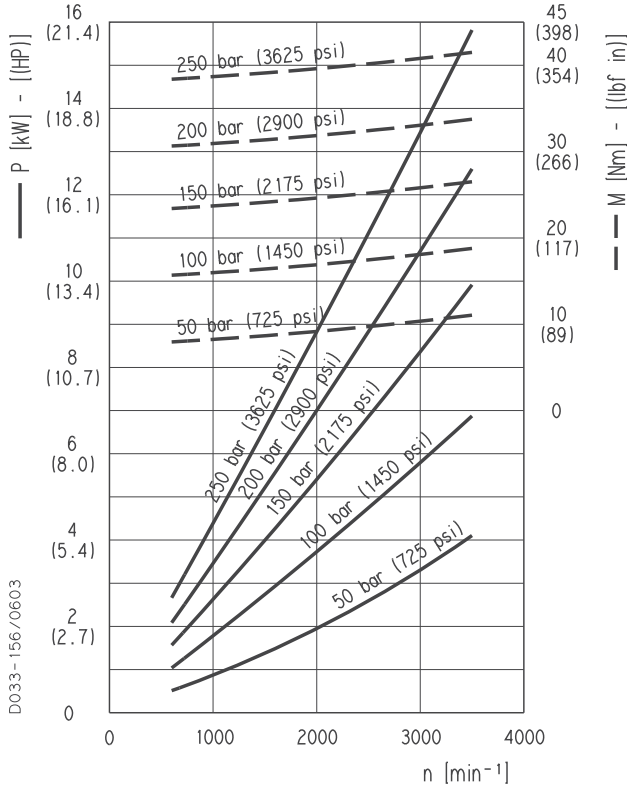

PLP 20•10,5

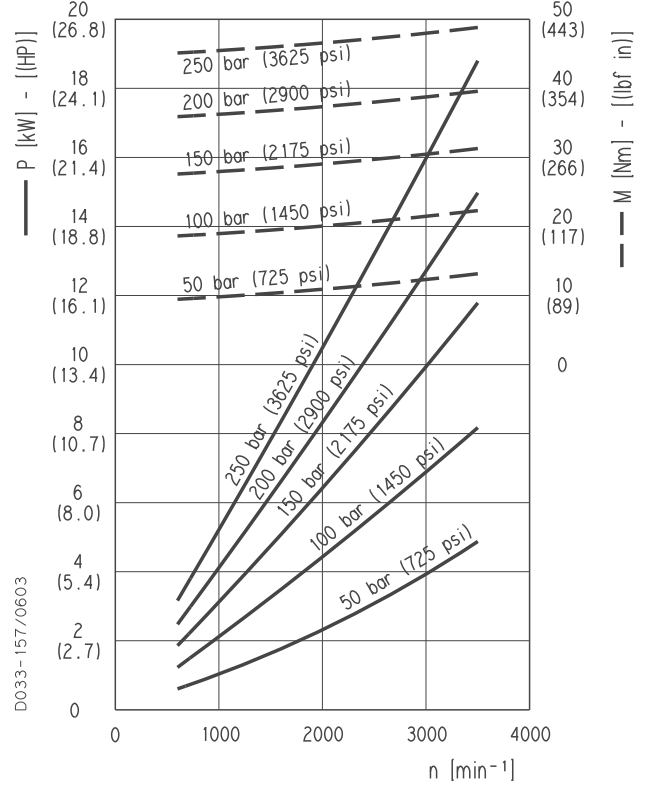

PLP 20•11,2

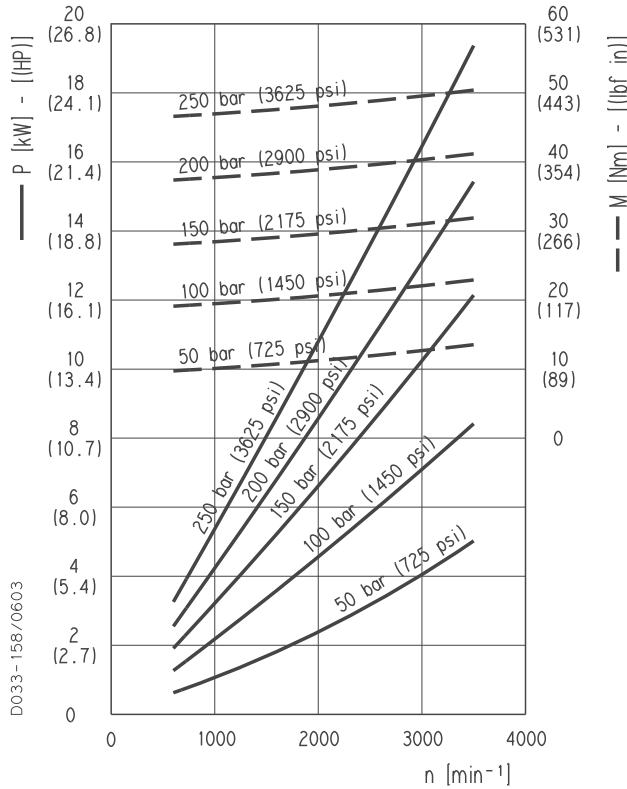

PLP 20•14

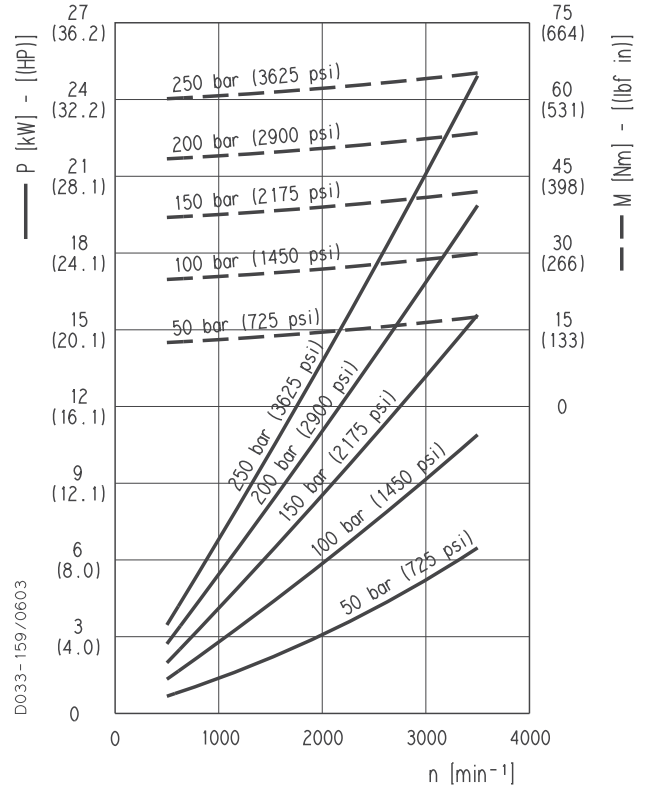

01/10.03

PLP 20

POLARIS 20 GEAR PUMPS PERFORMANCE CURVES

PLP 20•16

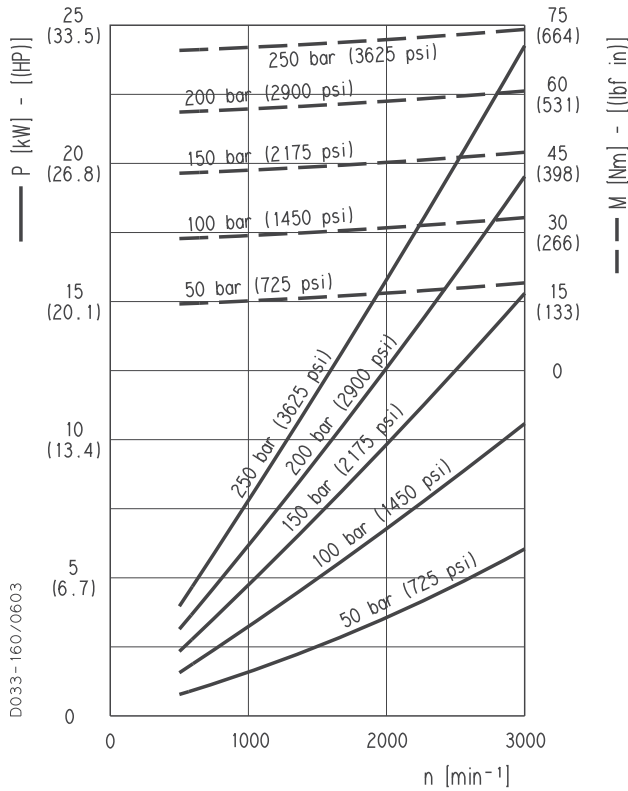

PLP 20•19

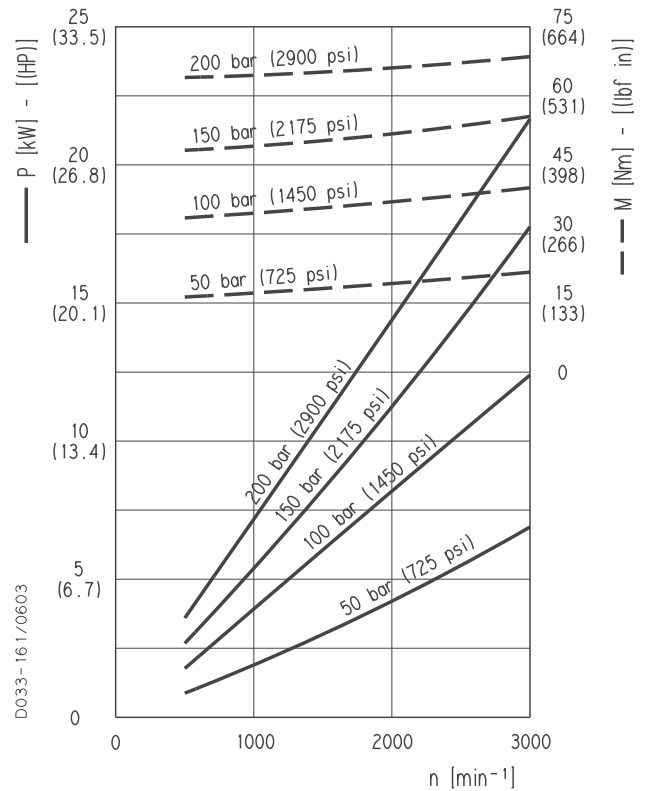

PLP 20•20

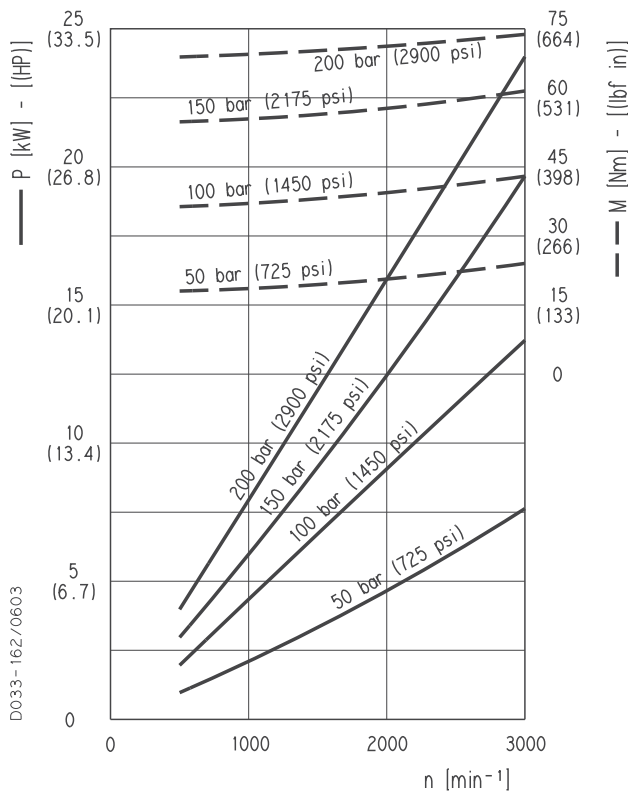

PLP 20•24,5

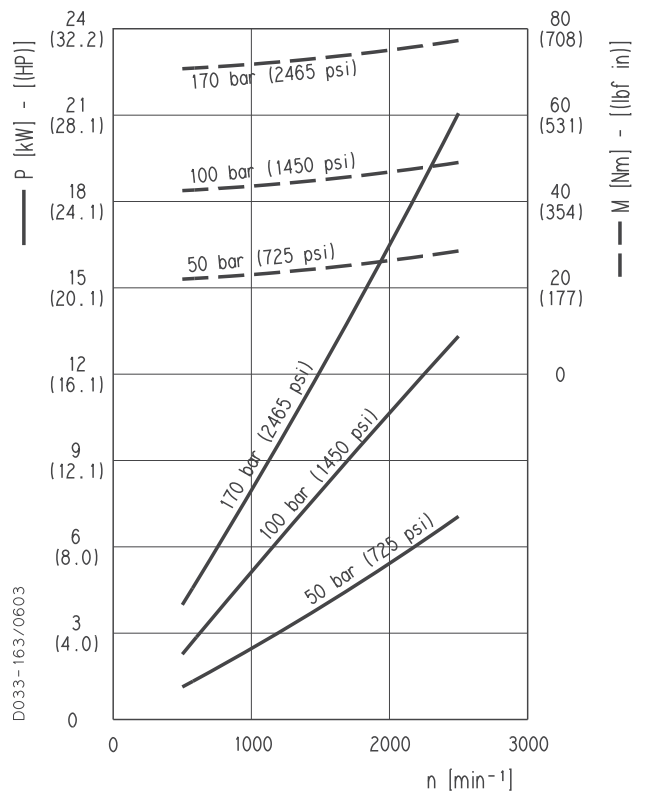

01/10.03

PLP 20

POLARIS 20 GEAR PUMPS PERFORMANCE CURVES

PLP 20•25

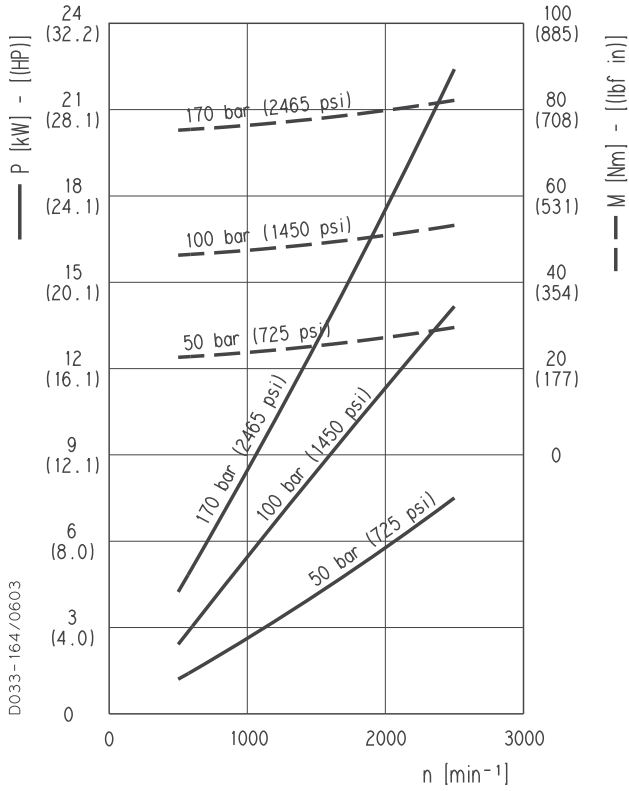

PLP 20•27,8

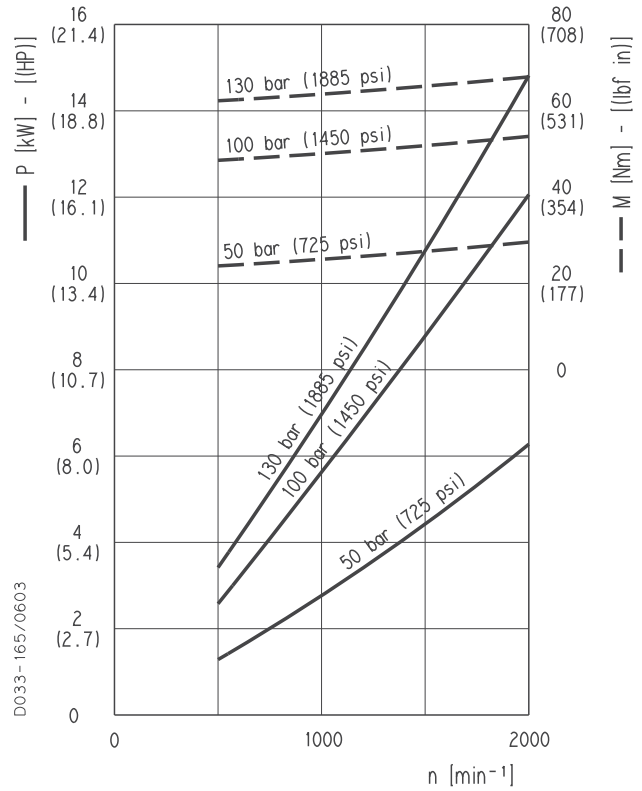

PLP 20•31,5

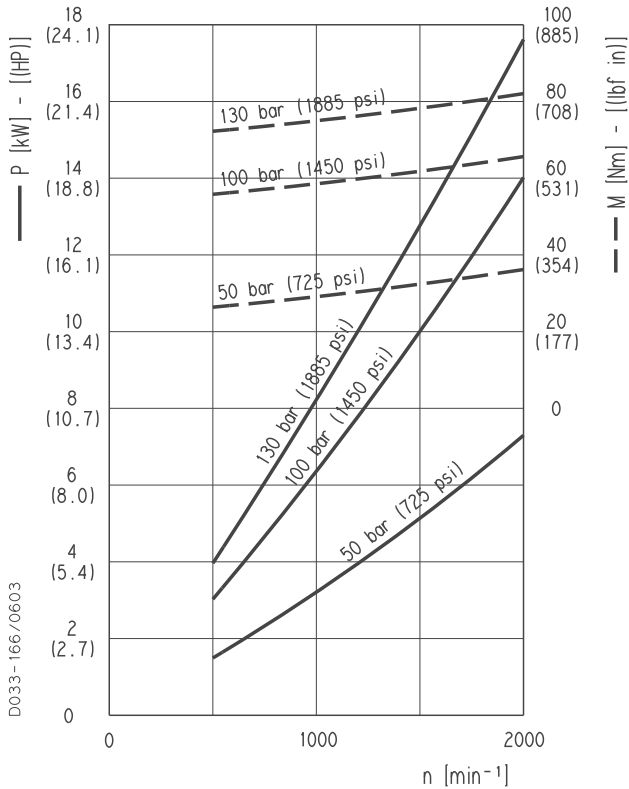

01/10.03

PLP 30

POLARIS 30 GEAR PUMPS PERFORMANCE CURVES

Each curve has been obtained at 122 °F (50°C), using oil with viscosity 168 SSU (36 cSt) at 104 °F (40°C) and at these pressures.

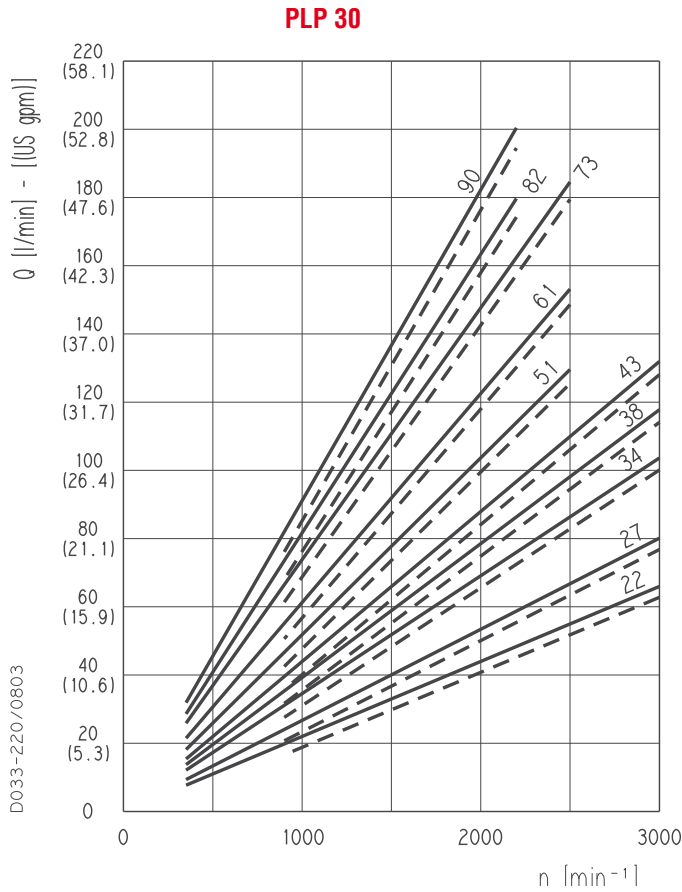

PLP 30•22	—	290 psi (20 bar)
	- -	3625 psi (250 bar)
PLP 30•27	—	290 psi (20 bar)
	- -	3625 psi (250 bar)
PLP 30•34	—	290 psi (20 bar)
	- -	3480 psi (240 bar)
PLP 30•38	—	290 psi (20 bar)
	- -	3480 psi (240 bar)
PLP 30•43	—	290 psi (20 bar)
	- -	3335 psi (230 bar)
PLP 30•51	—	290 psi (20 bar)
	- -	3045 psi (210 bar)
PLP 30•61	—	290 psi (20 bar)
	- -	2775 psi (190 bar)
PLP 30•73	—	290 psi (20 bar)
	- -	2465 psi (170 bar)
PLP 30•82	—	290 psi (20 bar)
	- -	2320 psi (160 bar)
PLP 30•90	—	290 psi (20 bar)
	- -	2175 psi (150 bar)

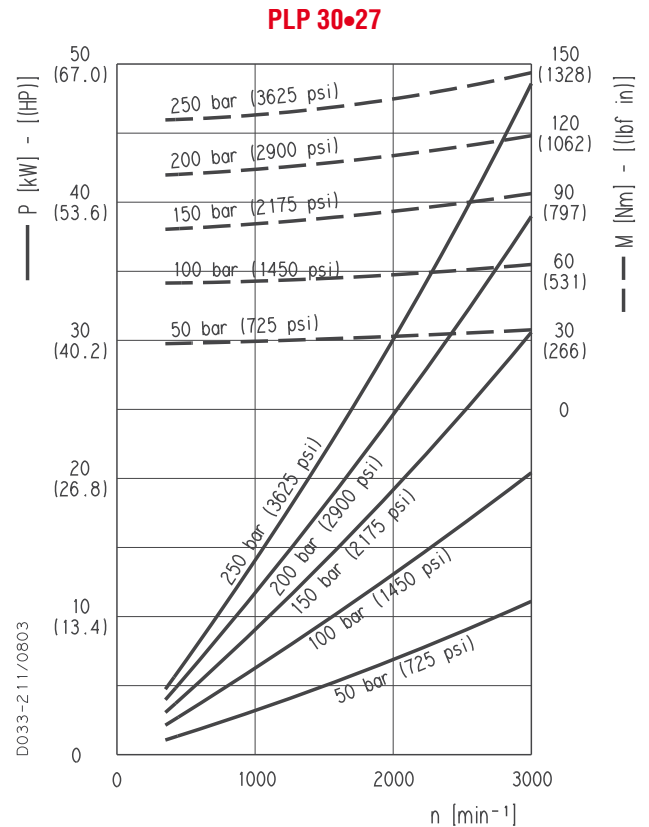
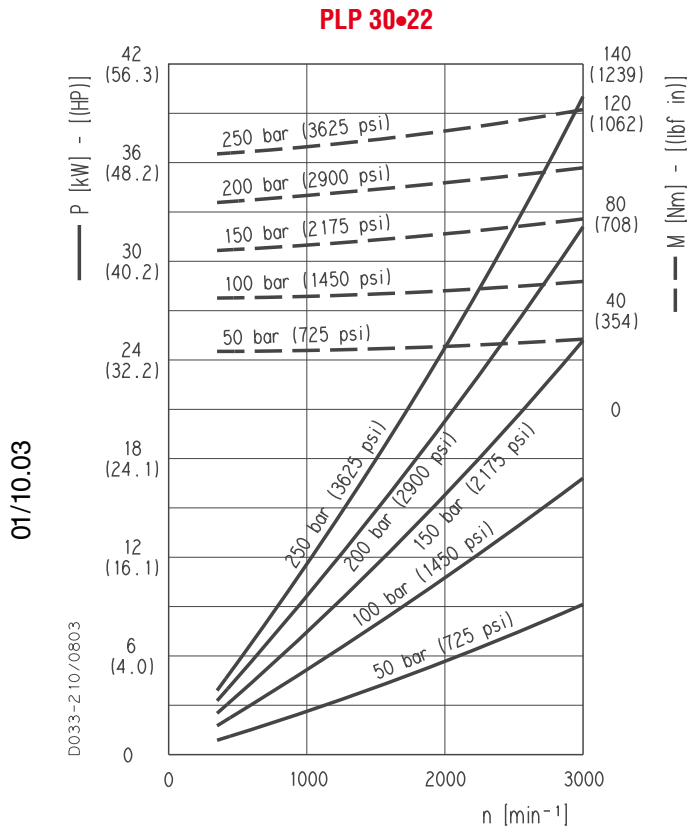

01/10.03

D033-2 10/0803

D033-2 11/0803

PLP 30

POLARIS 30 GEAR PUMPS PERFORMANCE CURVES

PLP 30•34

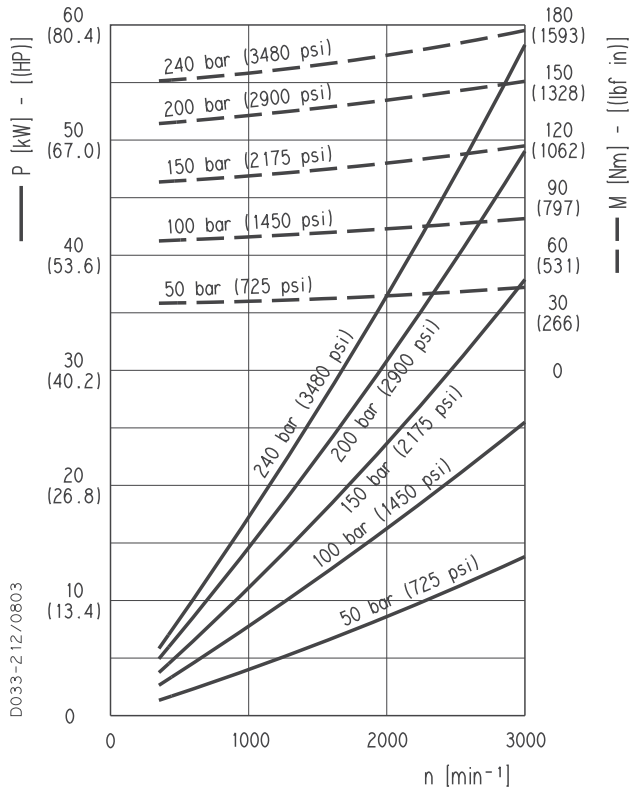

PLP 30•38

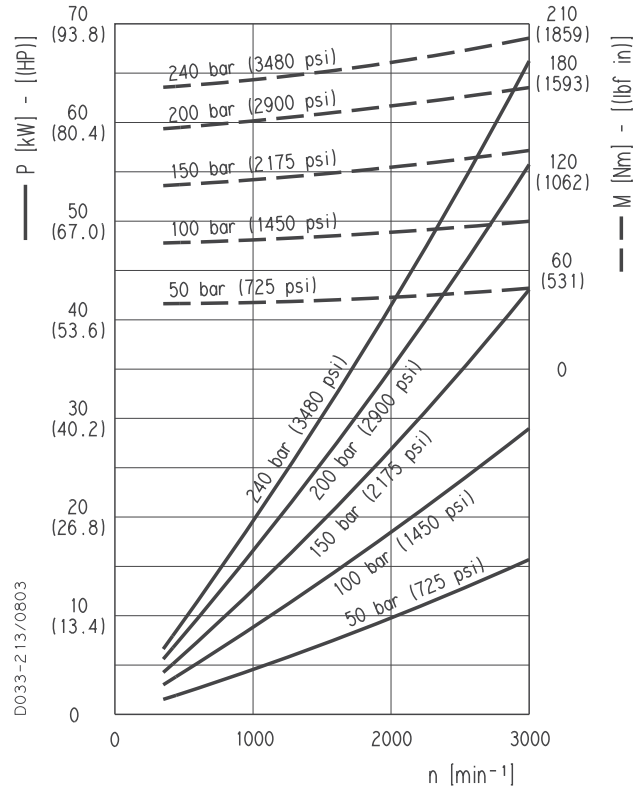

PLP 30•43

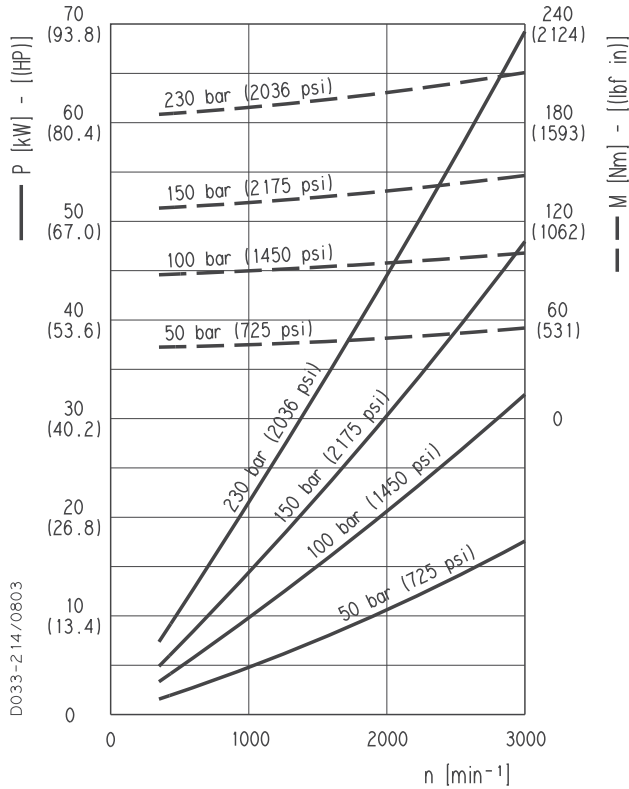

PLP 30•51

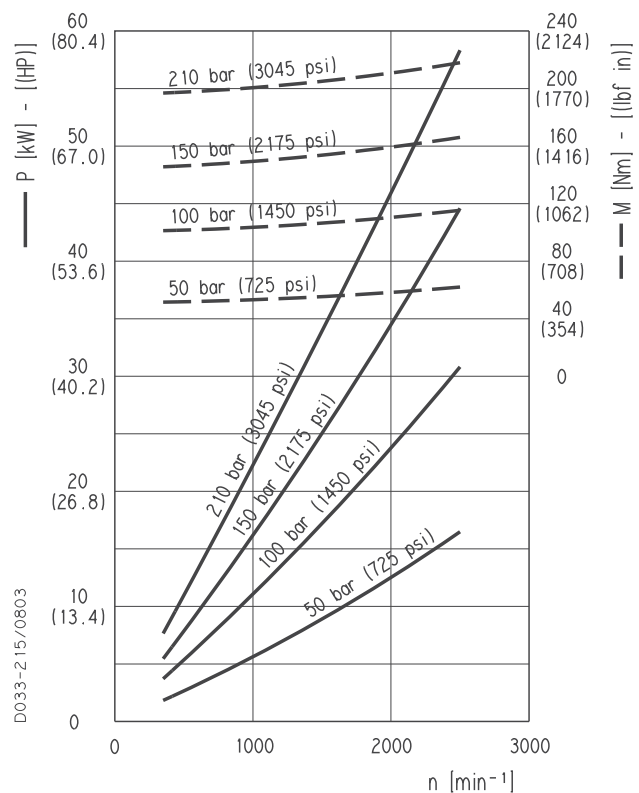

01/10.03

PLP 30

POLARIS 30 GEAR PUMPS PERFORMANCE CURVES

PLP 30•61

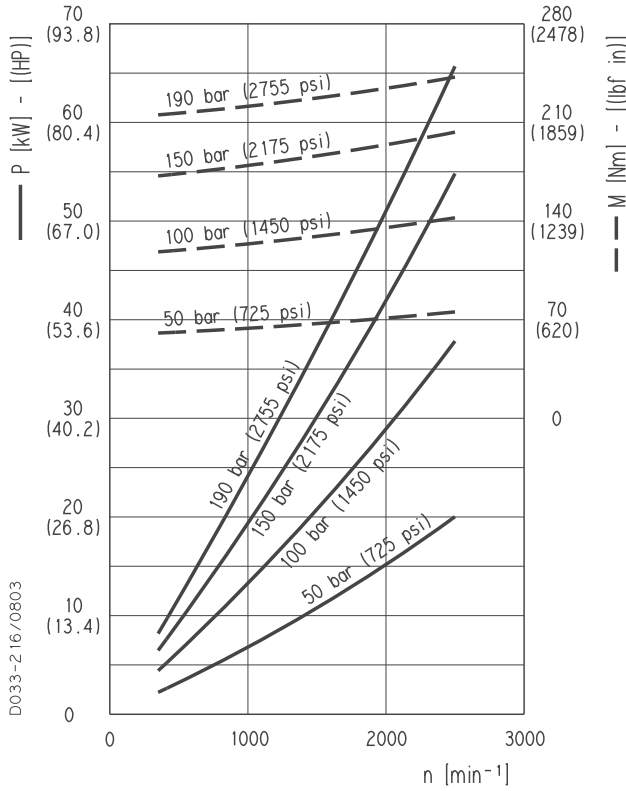

PLP 30•73

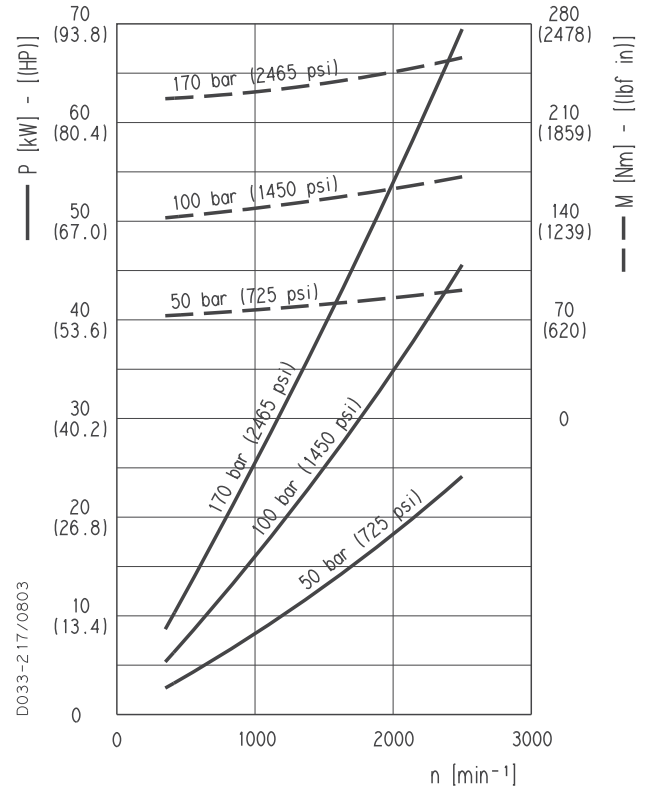

PLP 30•82

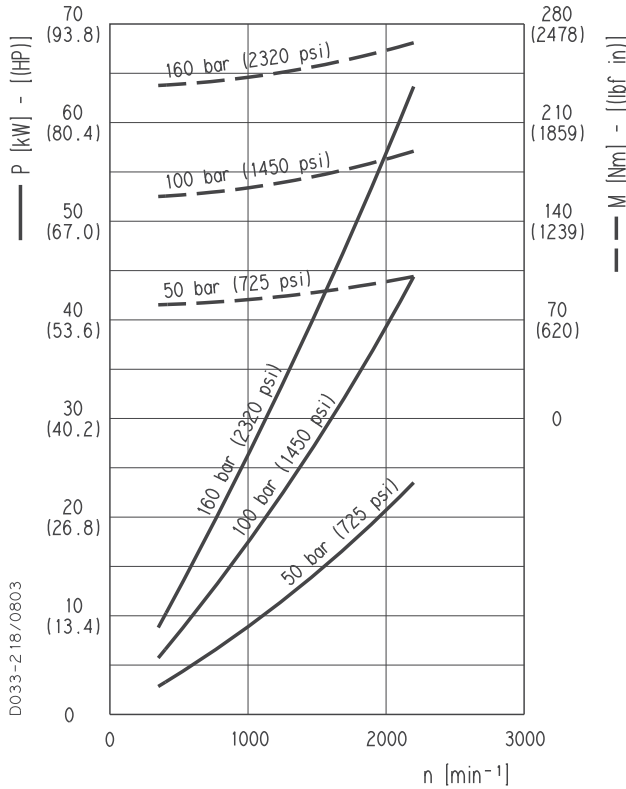

PLP 30•90

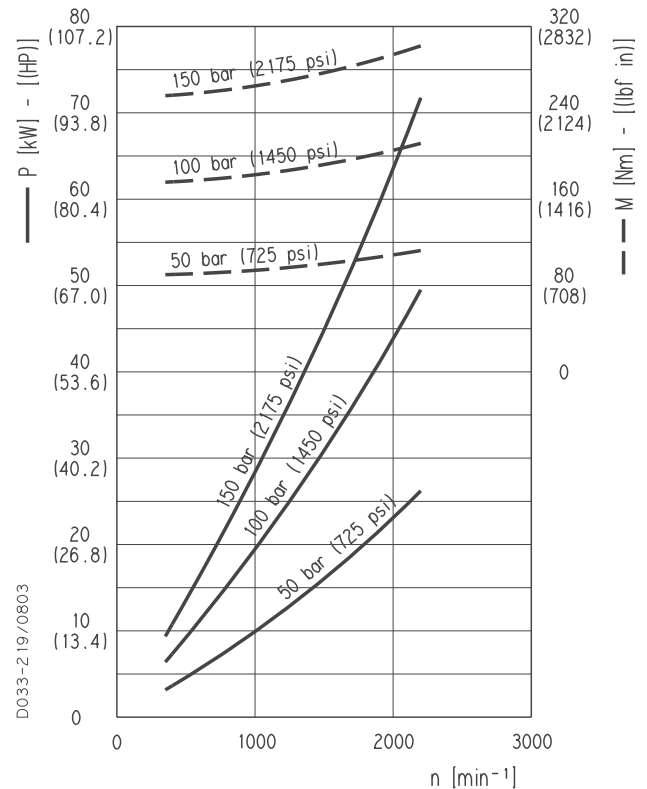

01/10.03

PLM 10

POLARIS 10 GEAR MOTORS PERFORMANCE CURVES

PLM 10

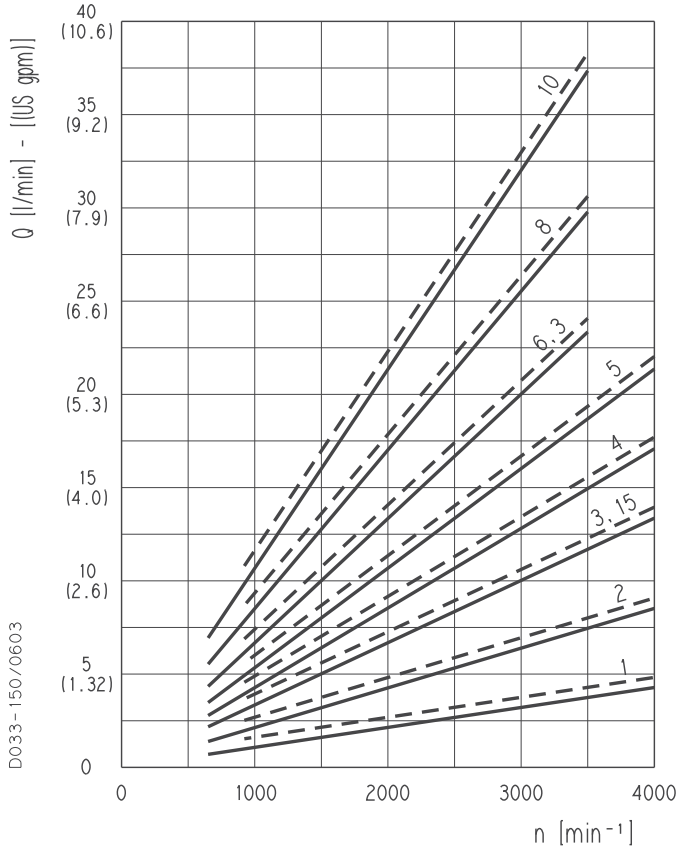

Each curve has been obtained at 122 °F (50°C), using oil with viscosity 168 SSU (36 cSt) at 104 °F (40°C) and at these pressures.

PLM 10•1	—	290 psi (20 bar)
	- -	3770 psi (260 bar)
PLM 10•2	—	290 psi (20 bar)
	- -	3770 psi (260 bar)
PLM 10•3,15	—	290 psi (20 bar)
	- -	3770 psi (260 bar)
PLM 10•4	—	290 psi (20 bar)
	- -	3625 psi (250 bar)
PLM 10•5	—	290 psi (20 bar)
	- -	3625 psi (250 bar)
PLM 10•6,3	—	290 psi (20 bar)
	- -	3335 psi (230 bar)
PLM 10•8	—	290 psi (20 bar)
	- -	2610 psi (180 bar)
PLM 10•10	—	290 psi (20 bar)
	- -	2030 psi (140 bar)

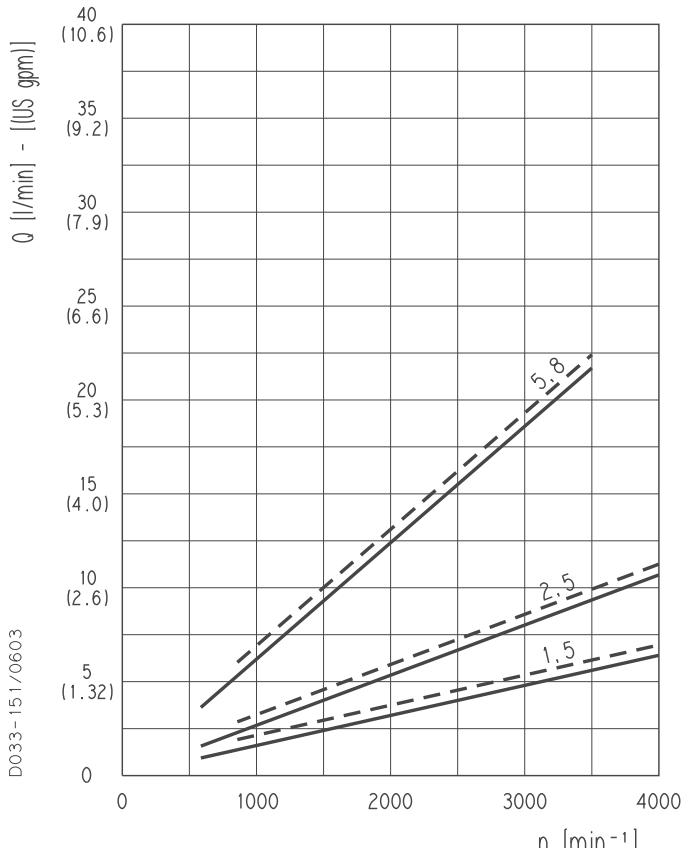

PLM 10•1,5	—	290 psi (20 bar)
	- -	3770 psi (260 bar)
PLM 10•2,5	—	290 psi (20 bar)
	- -	3770 psi (260 bar)
PLM 10•5,8	—	290 psi (20 bar)
	- -	3335 psi (230 bar)

01/10.03

PLM 10

POLARIS 10 GEAR MOTORS PERFORMANCE CURVES

PLM 10•1

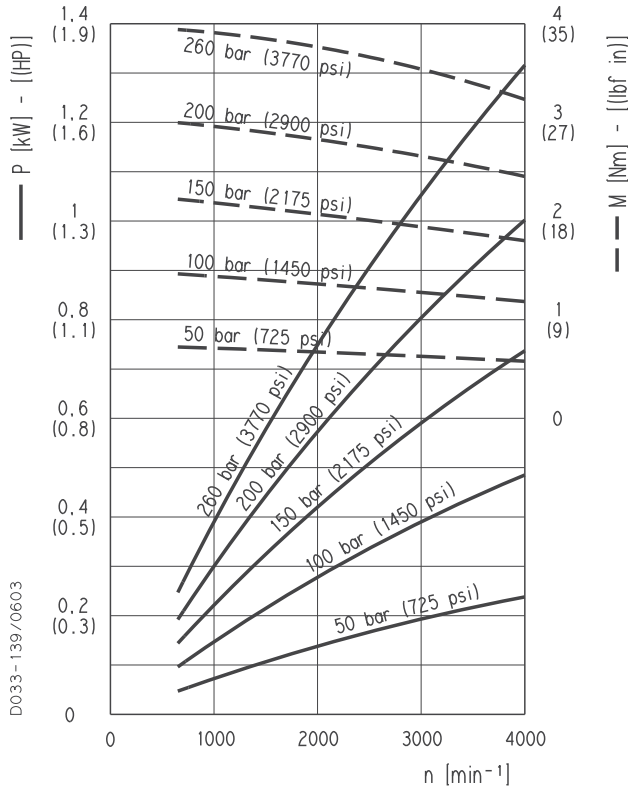

PLM 10•1,5

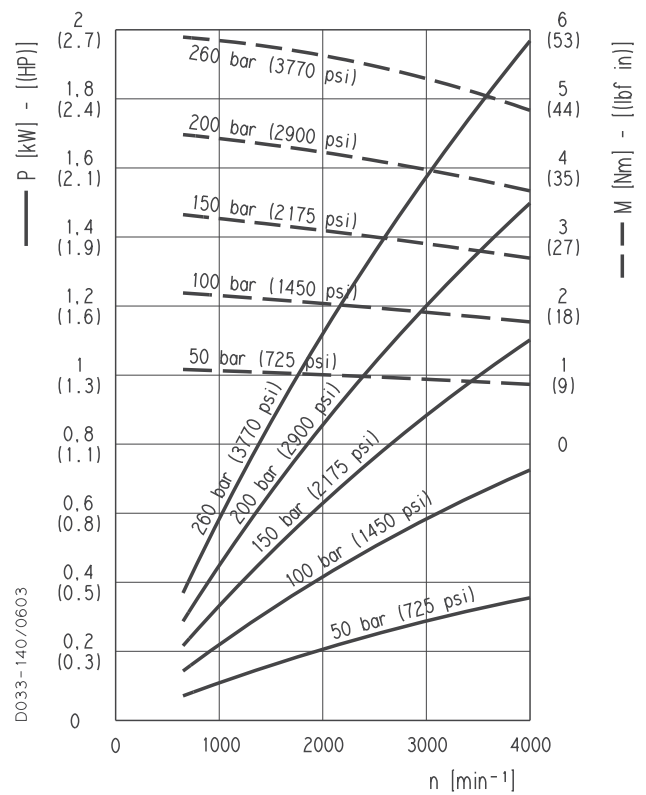

PLM 10•2

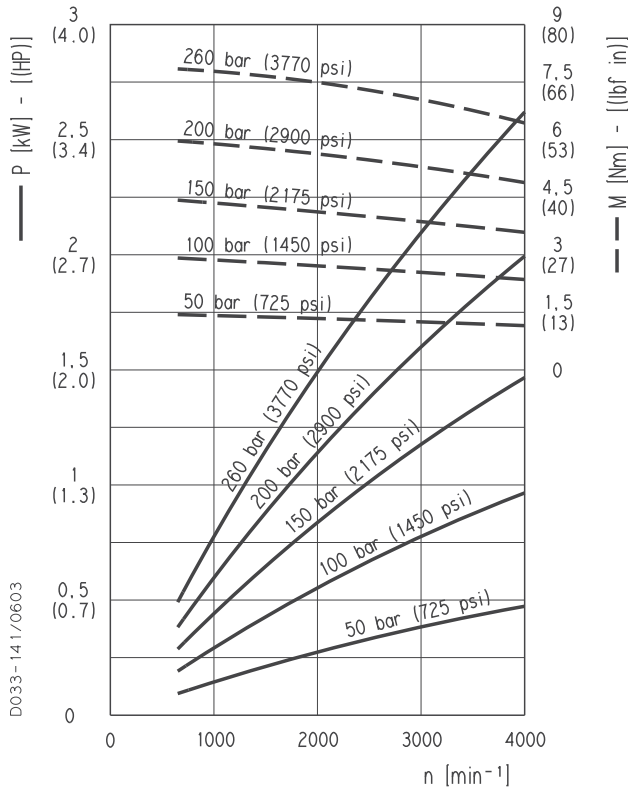

PLM 10•2,5

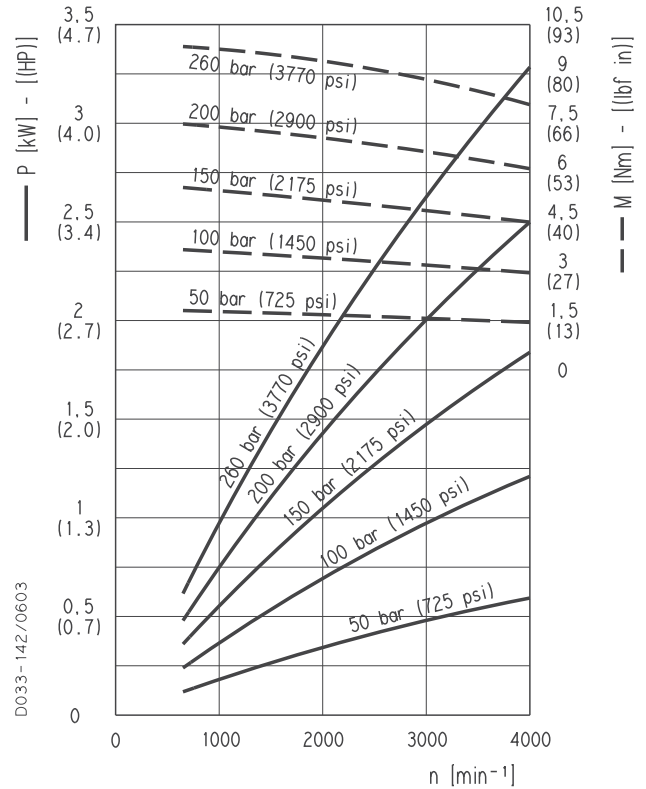

01/10.03

PLM 10

POLARIS 10 GEAR MOTORS PERFORMANCE CURVES

PLM 10•3,15

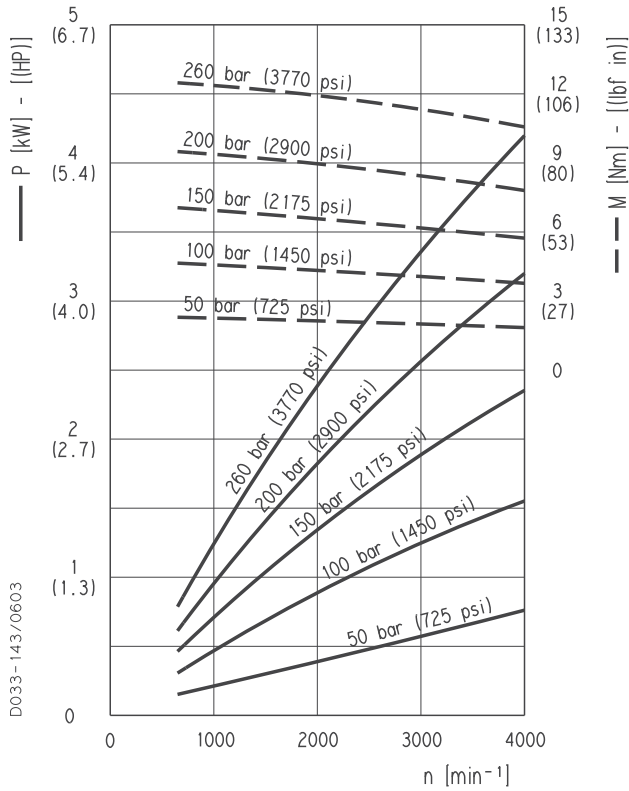

PLM 10•4

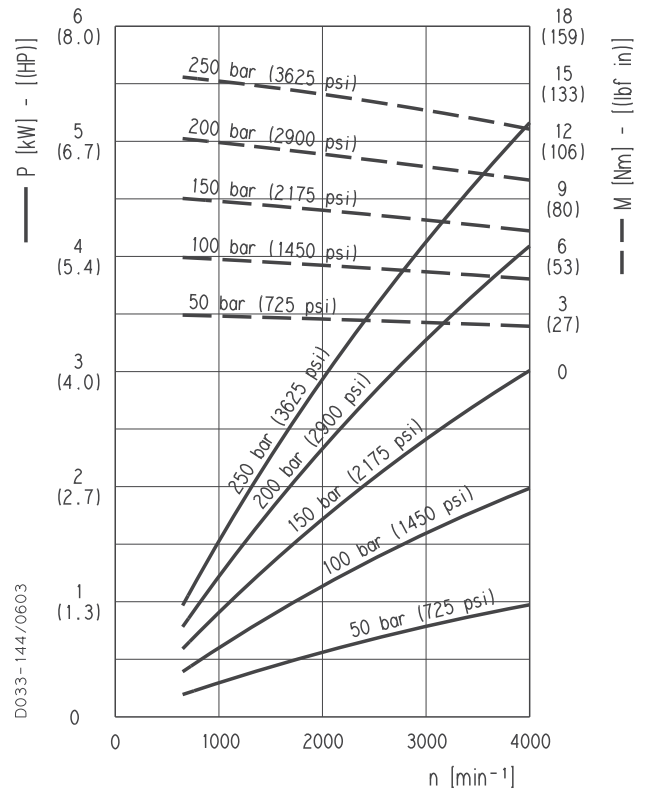

PLM 10•5

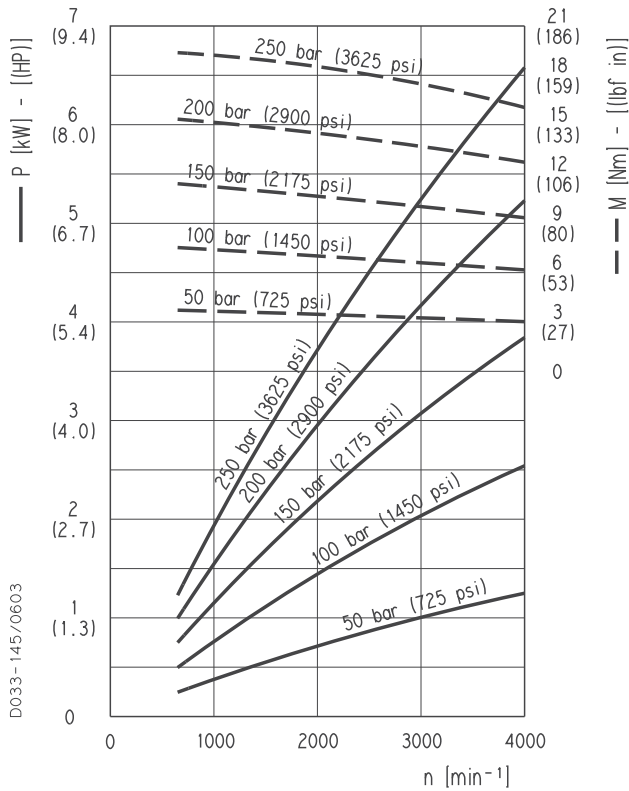

PLM 10•5,8

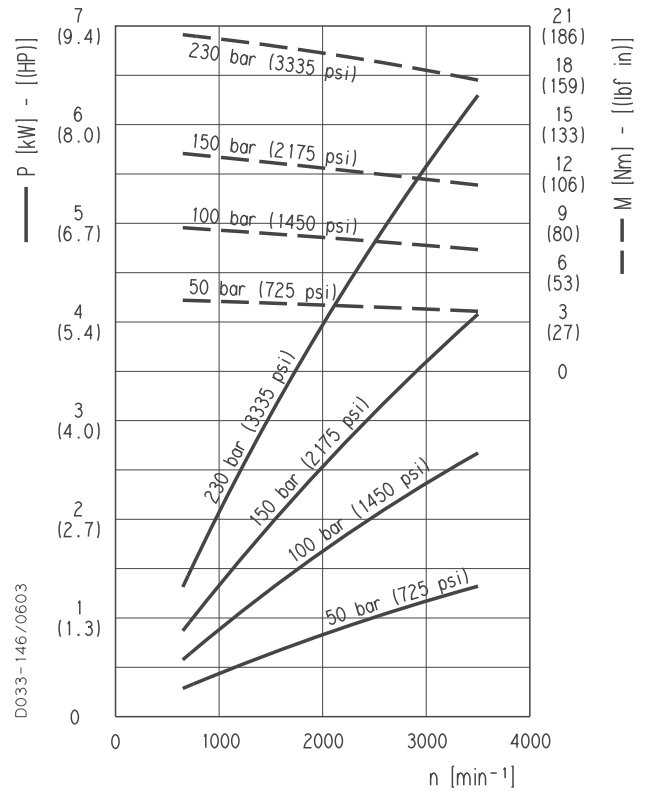

01/10.03

PLM 10

POLARIS 10 GEAR MOTORS PERFORMANCE CURVES

PLM 10•6,3

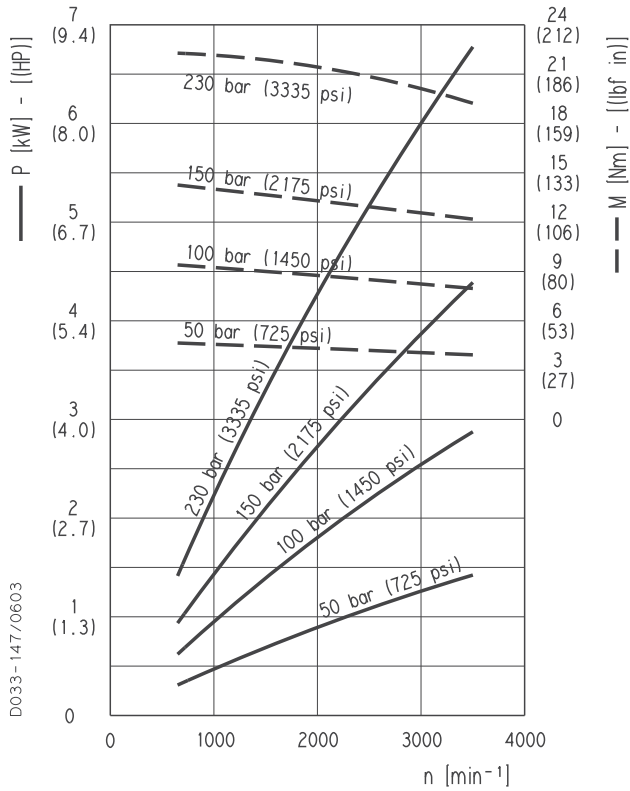

PLM 10•8

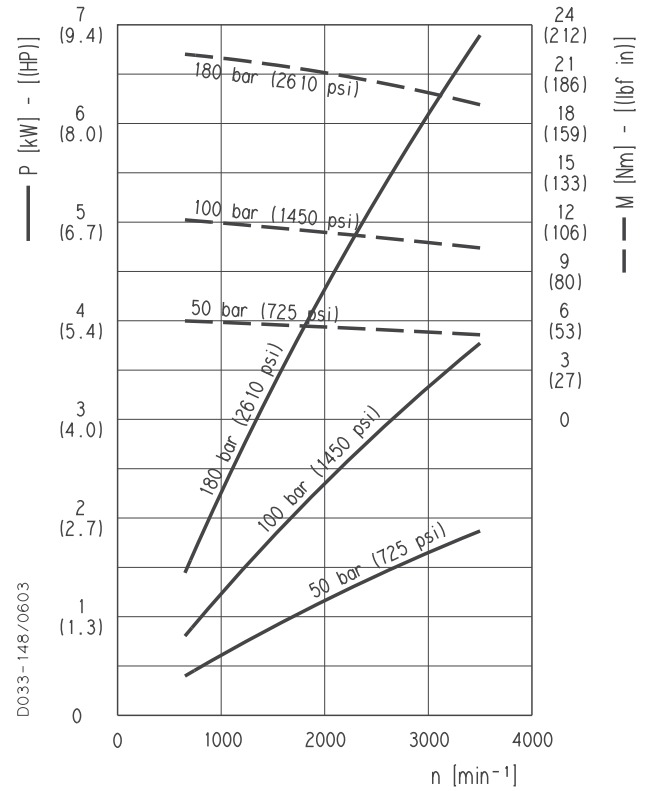

PLM 10•10

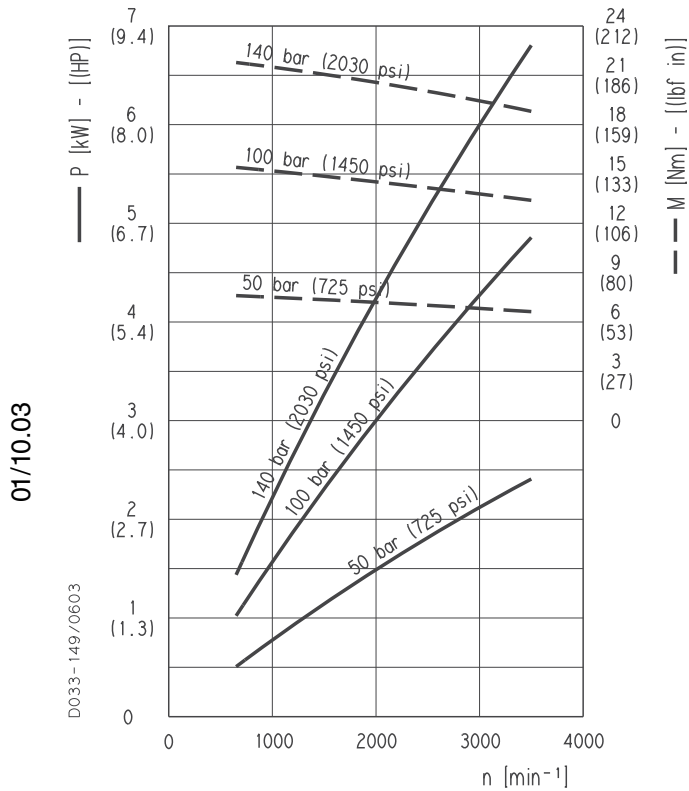

01/10.03

PLM 20

POLARIS 20 GEAR MOTORS PERFORMANCE CURVES

Each curve has been obtained at 122 °F (50°C), using oil with viscosity 168 SSU (36 cSt) at 104 °F (40°C) and at these pressures.

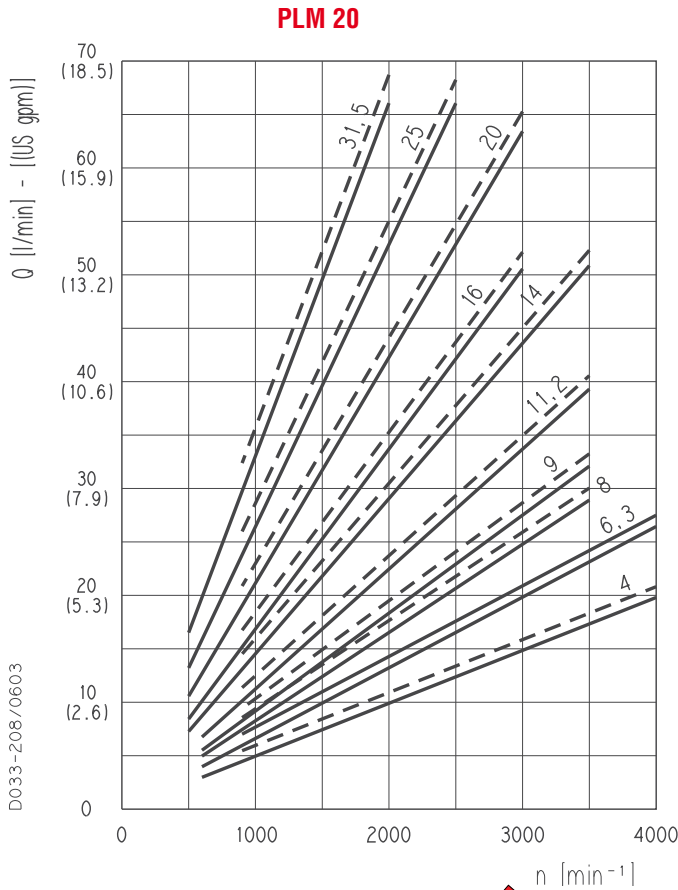

PLM 20•4	—	290 psi (20 bar)
	- -	3625 psi (250 bar)
PLM 20•6,3	—	290 psi (20 bar)
	- -	3625 psi (250 bar)
PLM 20•8	—	290 psi (20 bar)
	- -	3625 psi (250 bar)
PLM 20•9	—	290 psi (20 bar)
	- -	3625 psi (250 bar)
PLM 20•11,2	—	290 psi (20 bar)
	- -	3625 psi (250 bar)
PLM 20•14	—	290 psi (20 bar)
	- -	3625 psi (250 bar)
PLM 20•16	—	290 psi (20 bar)
	- -	3625 psi (250 bar)
PLM 20•20	—	290 psi (20 bar)
	- -	2900 psi (200 bar)
PLM 20•25	—	290 psi (20 bar)
	- -	2465 psi (170 bar)
PLM 20•31,5	—	290 psi (20 bar)
	- -	1885 psi (130 bar)

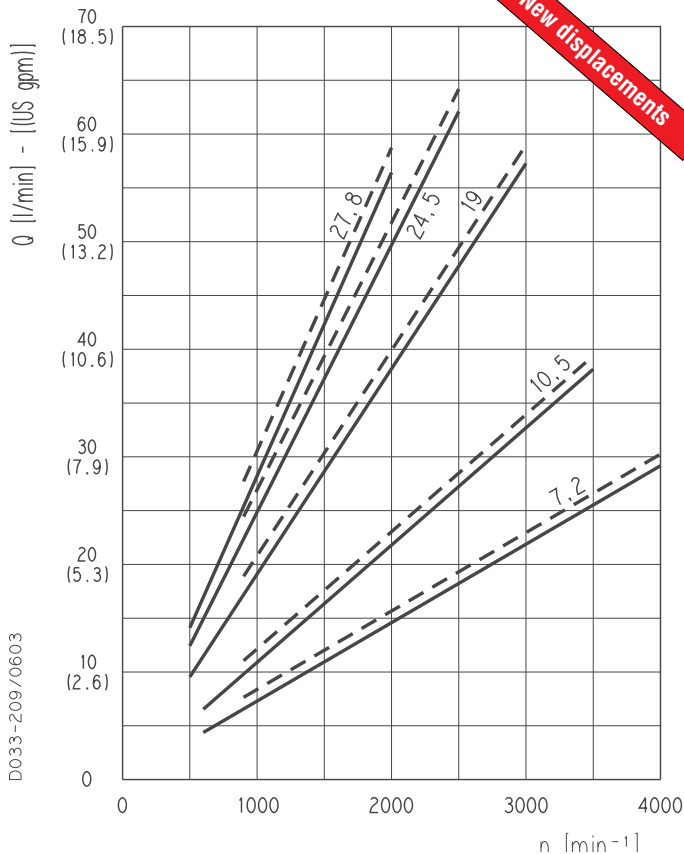

PLM 20•7,2	—	290 psi (20 bar)
	- -	3625 psi (250 bar)
PLM 20•10,5	—	290 psi (20 bar)
	- -	3625 psi (250 bar)
PLM 20•19	—	290 psi (20 bar)
	- -	2900 psi (200 bar)
PLM 20•24,5	—	290 psi (20 bar)
	- -	2465 psi (170 bar)
PLM 20•27,8	—	290 psi (20 bar)
	- -	1885 psi (130 bar)

01/10.03

PLM 20

POLARIS 20 GEAR MOTORS PERFORMANCE CURVES

PLM 20•4

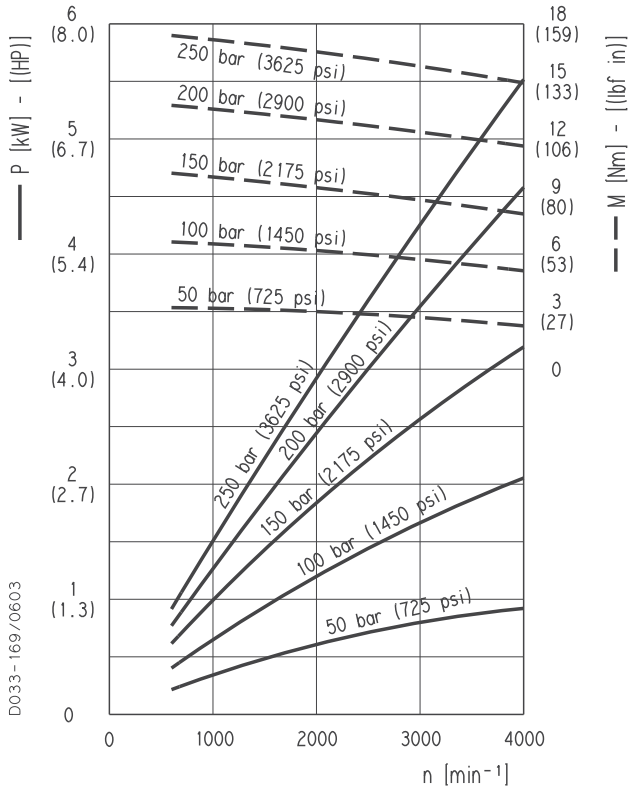

PLM 20•6,3

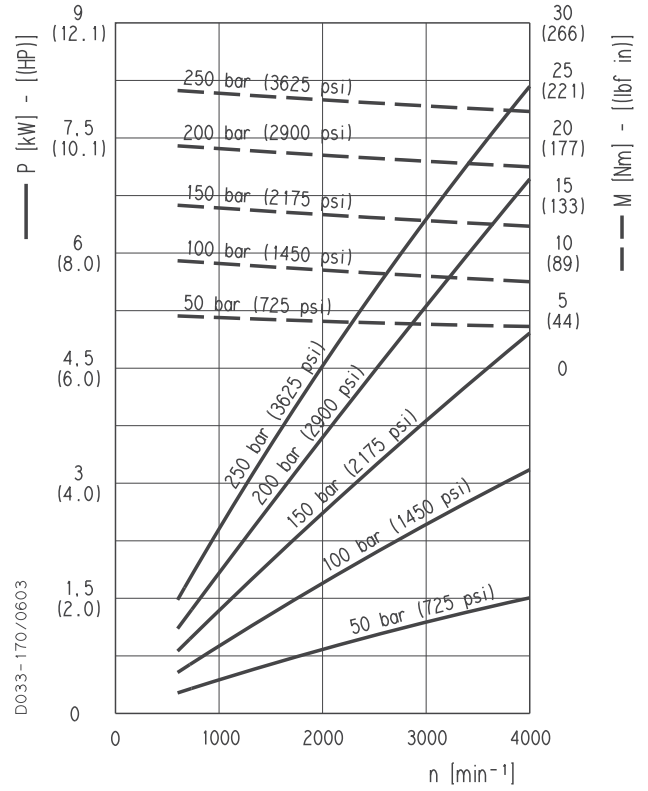

PLM 20•7,2

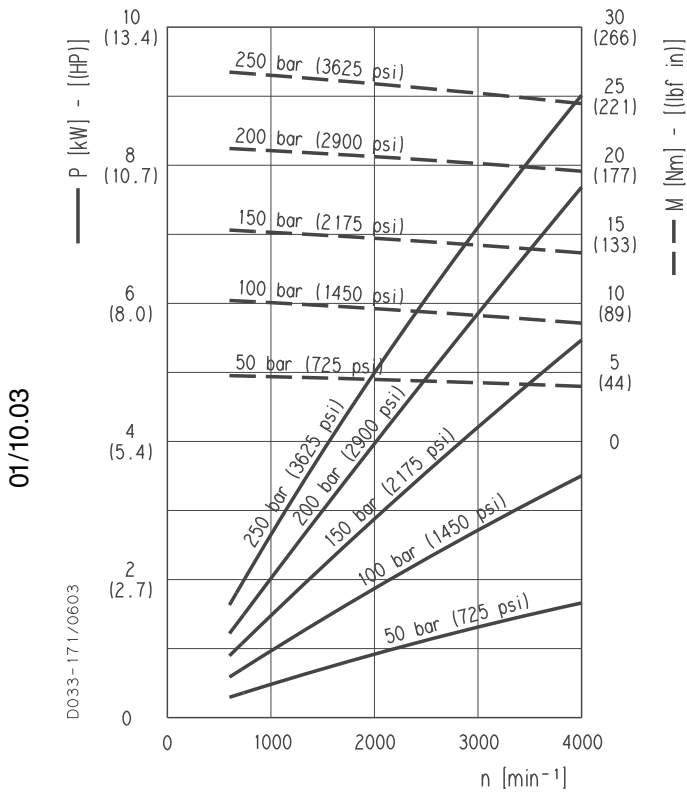

PLM 20•8

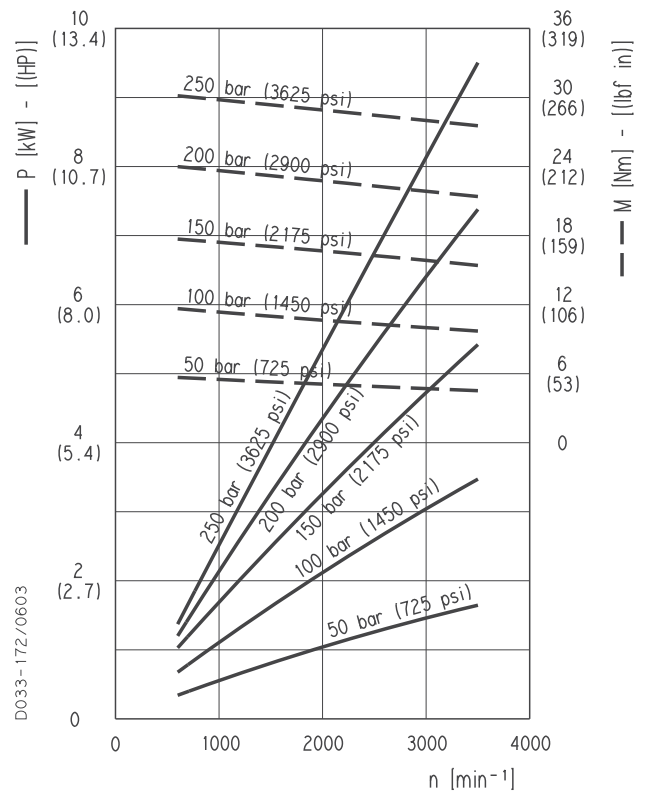

01/10.03

PLM 20

POLARIS 20 GEAR MOTORS PERFORMANCE CURVES

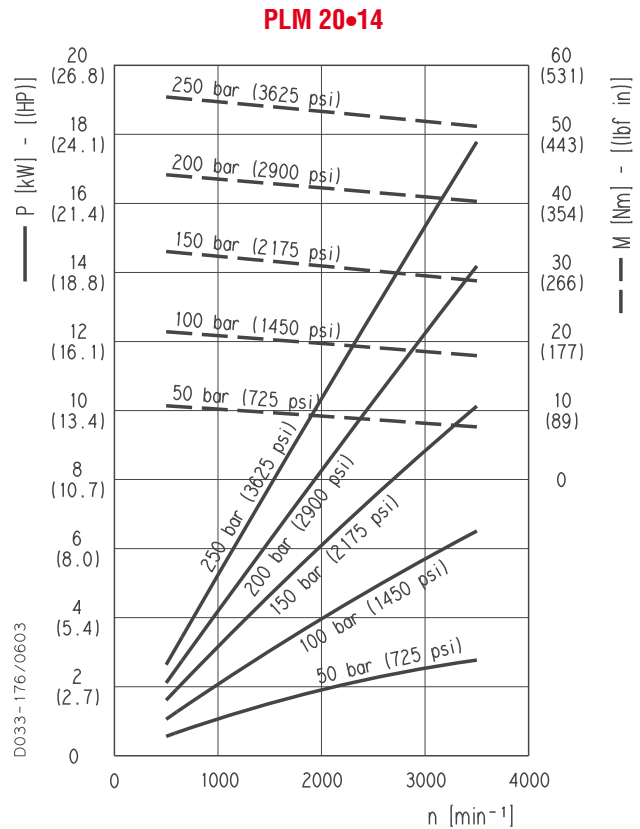
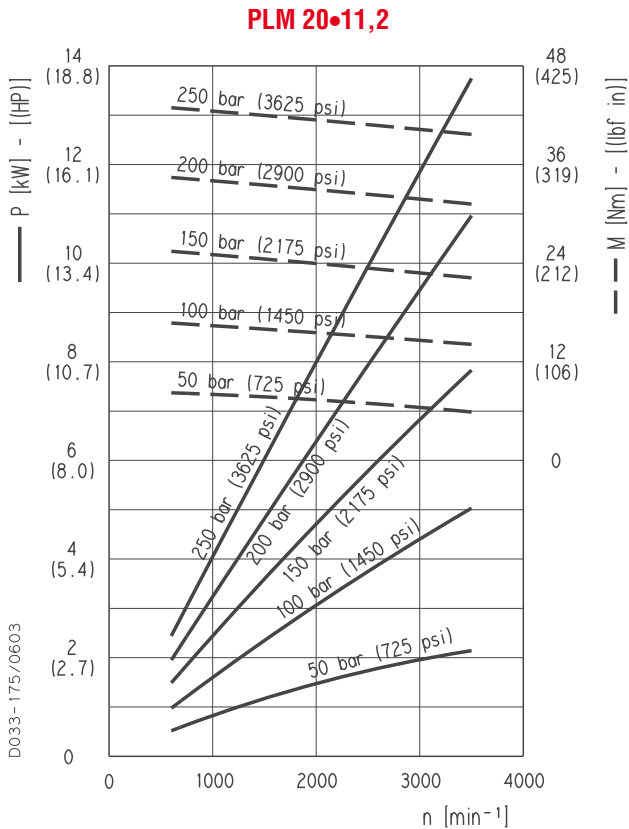
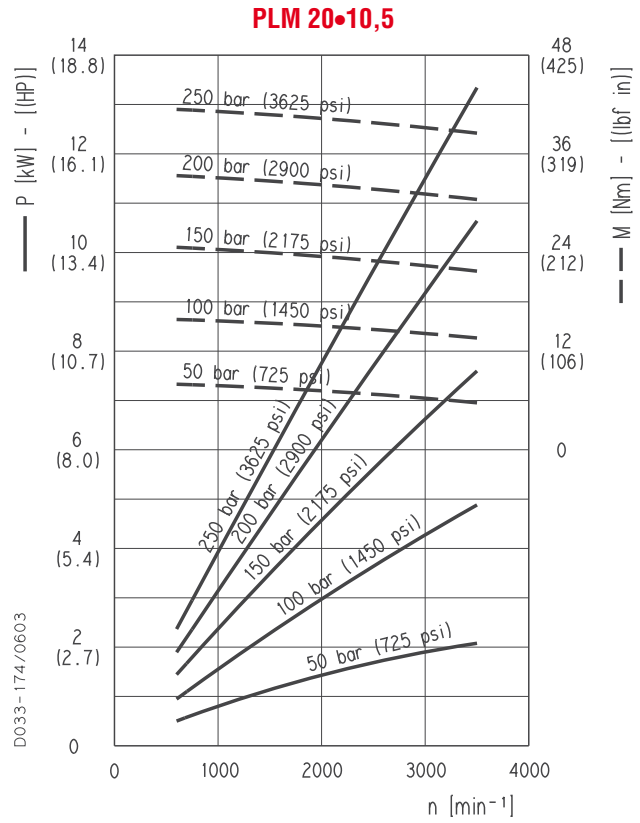
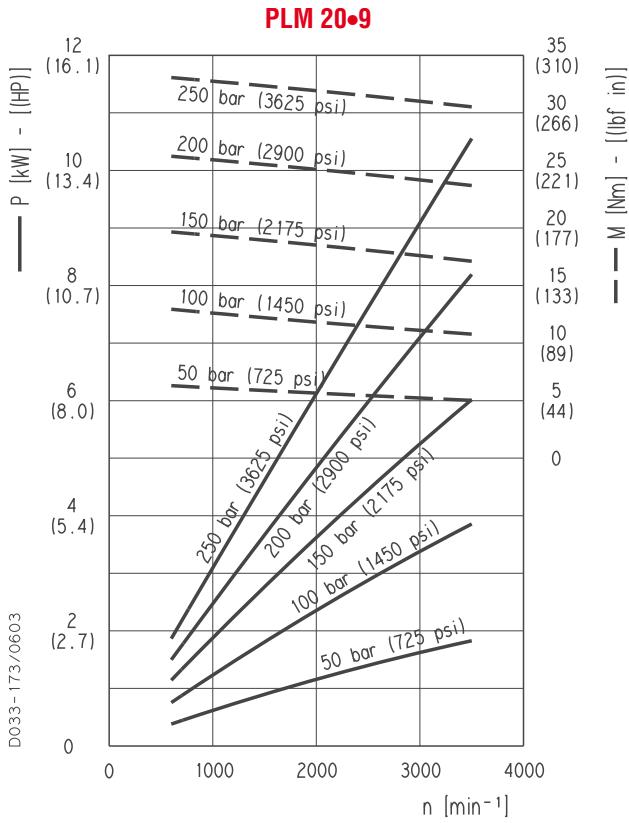

01/10.03

PLM 20

POLARIS 20 GEAR MOTORS PERFORMANCE CURVES

PLM 20•16

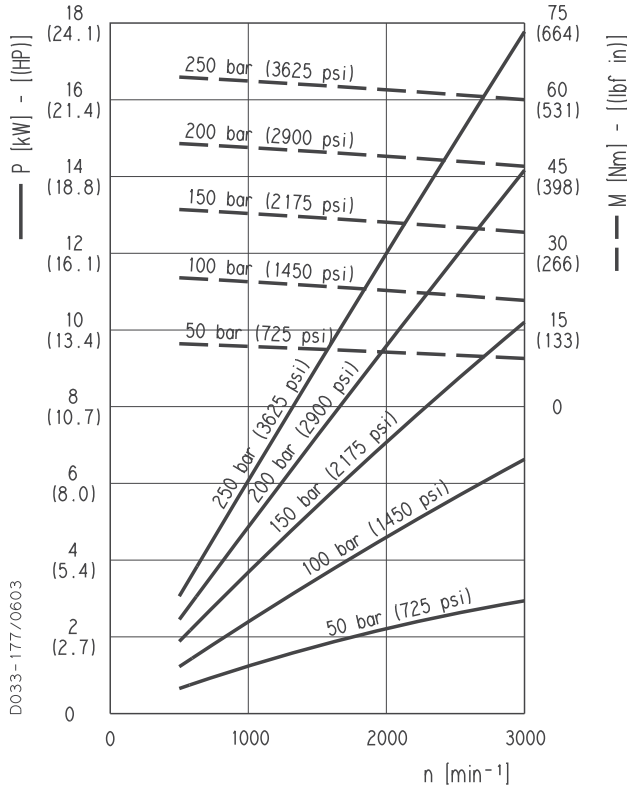

PLM 20•19

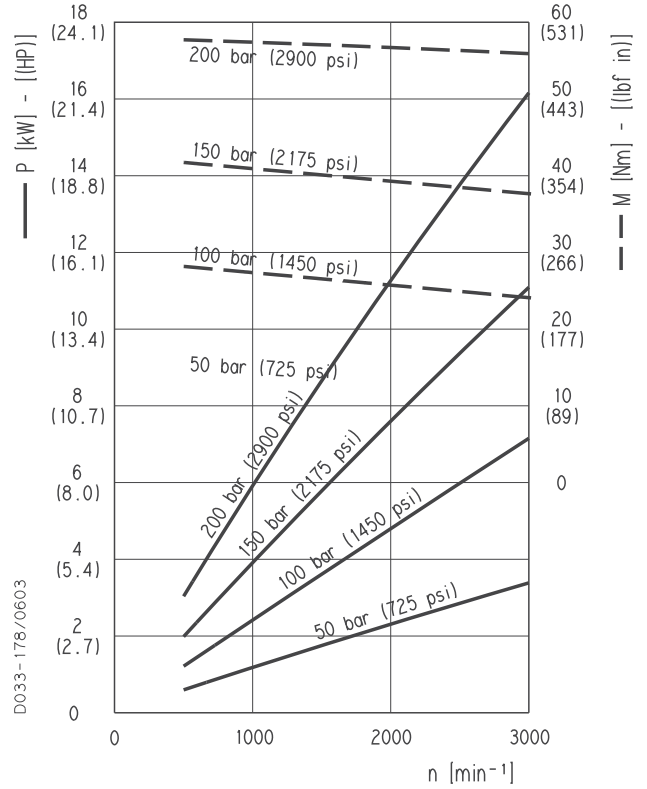

PLM 20•20

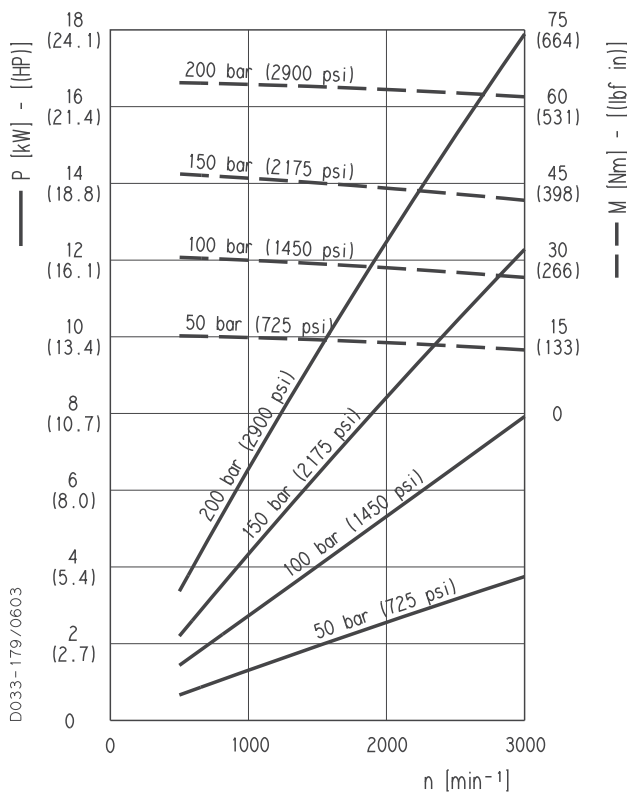

PLM 20•24,5

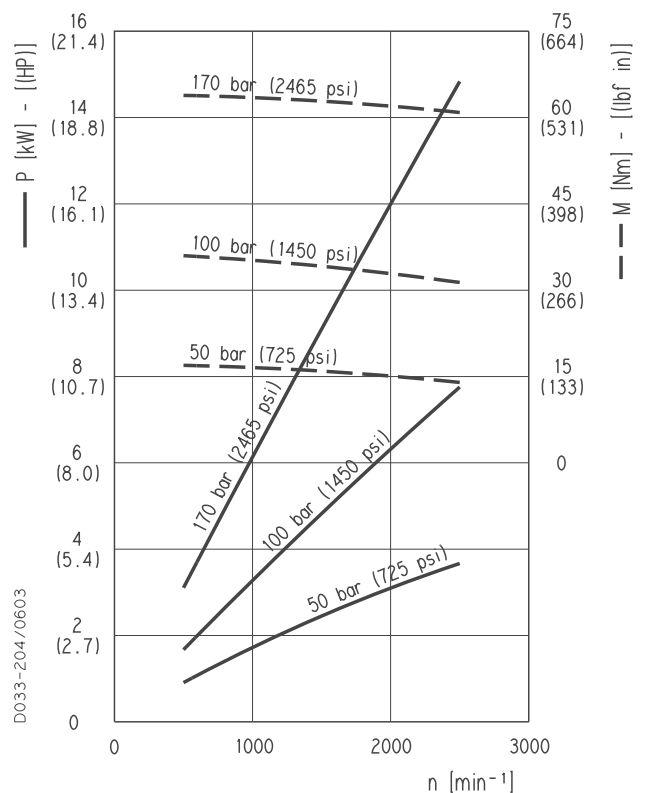

01/10.03

PLM 20

POLARIS 20 GEAR MOTORS PERFORMANCE CURVES

PLM 20•25

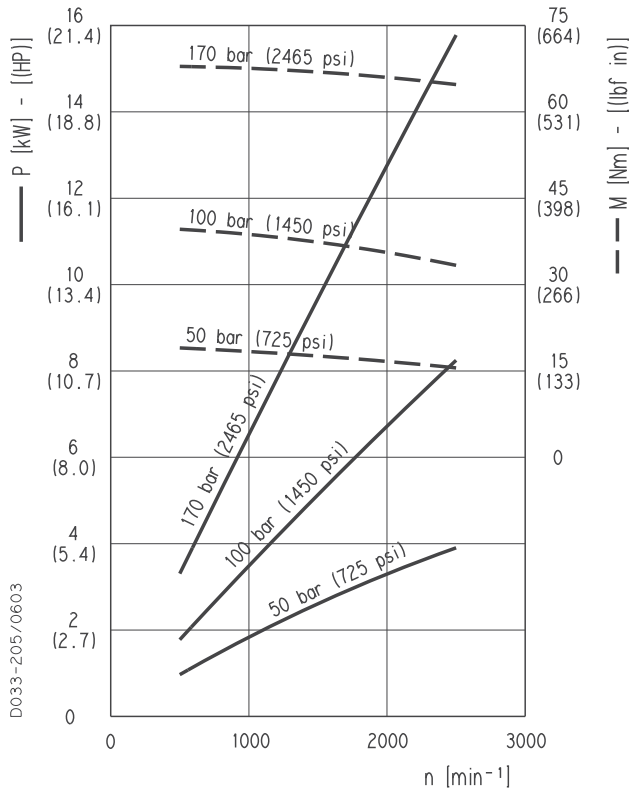

PLM 20•27,8

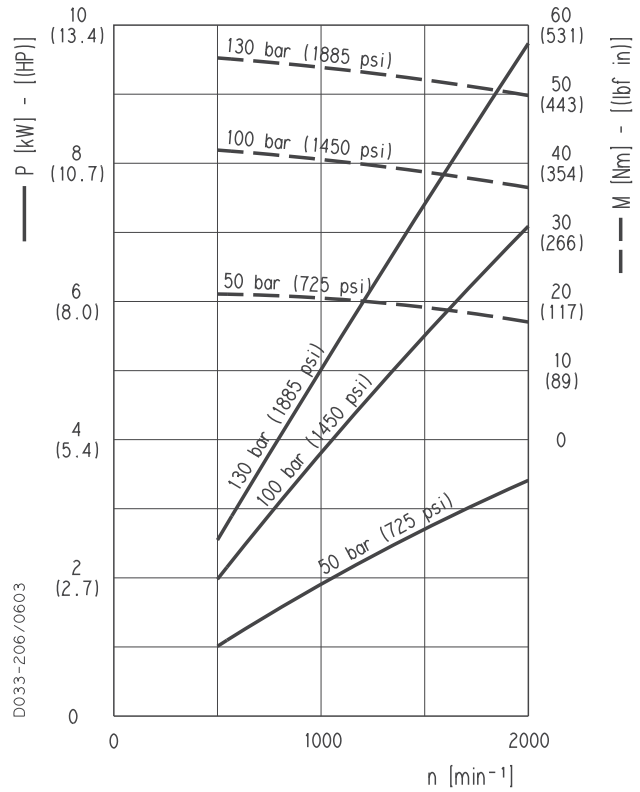

PLM 20•31,5

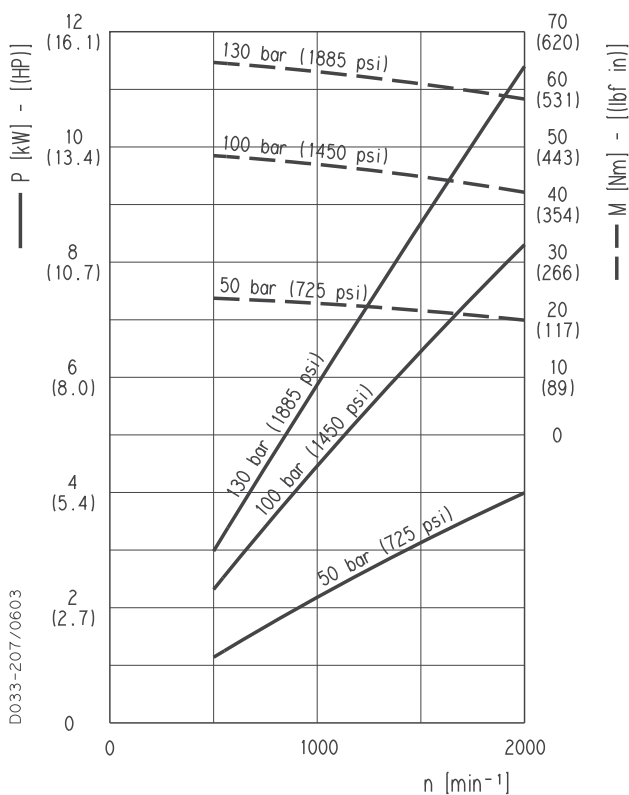

01/10.03

PLM 30

POLARIS 30 GEAR MOTORS PERFORMANCE CURVES

Each curve has been obtained at 122 °F (50°C), using oil with viscosity 168 SSU (36 cSt) at 104 °F (40°C) and at these pressures.

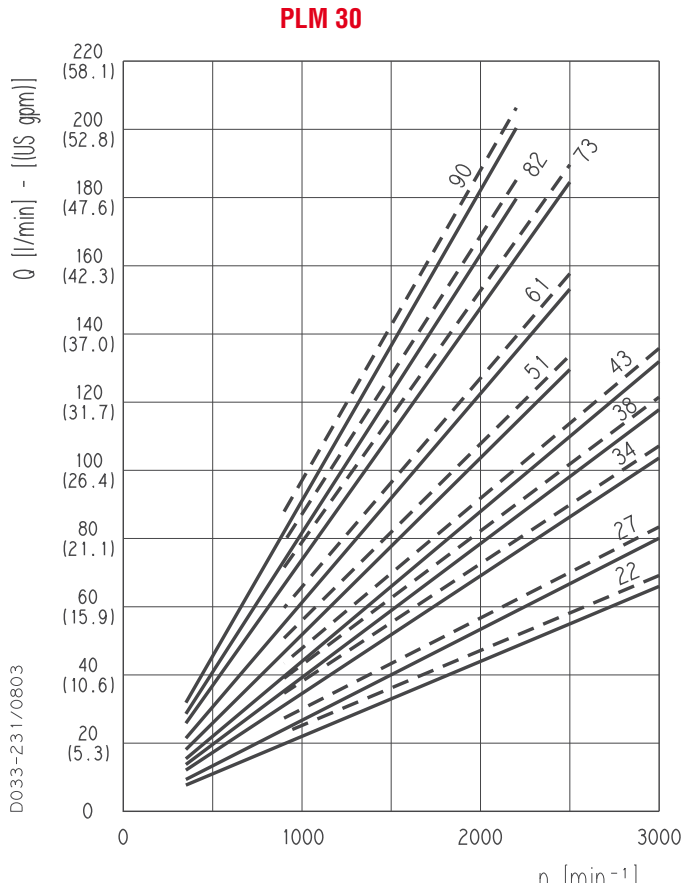

PLM 30•22	—	290 psi (20 bar)
	- -	3625 psi (250 bar)
PLM 30•27	—	290 psi (20 bar)
	- -	3625 psi (250 bar)
PLM 30•34	—	290 psi (20 bar)
	- -	3480 psi (240 bar)
PLM 30•38	—	290 psi (20 bar)
	- -	3480 psi (240 bar)
PLM 30•43	—	290 psi (20 bar)
	- -	3335 psi (230 bar)
PLM 30•51	—	290 psi (20 bar)
	- -	3045 psi (210 bar)
PLM 30•61	—	290 psi (20 bar)
	- -	2775 psi (190 bar)
PLM 30•73	—	290 psi (20 bar)
	- -	2465 psi (170 bar)
PLM 30•82	—	290 psi (20 bar)
	- -	2320 psi (160 bar)
PLM 30•90	—	290 psi (20 bar)
	- -	2175 psi (150 bar)

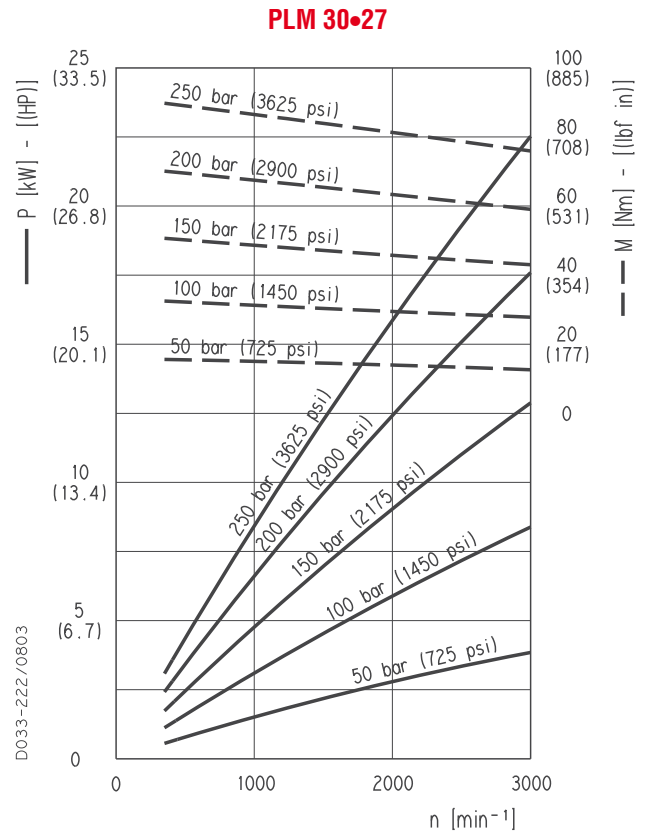
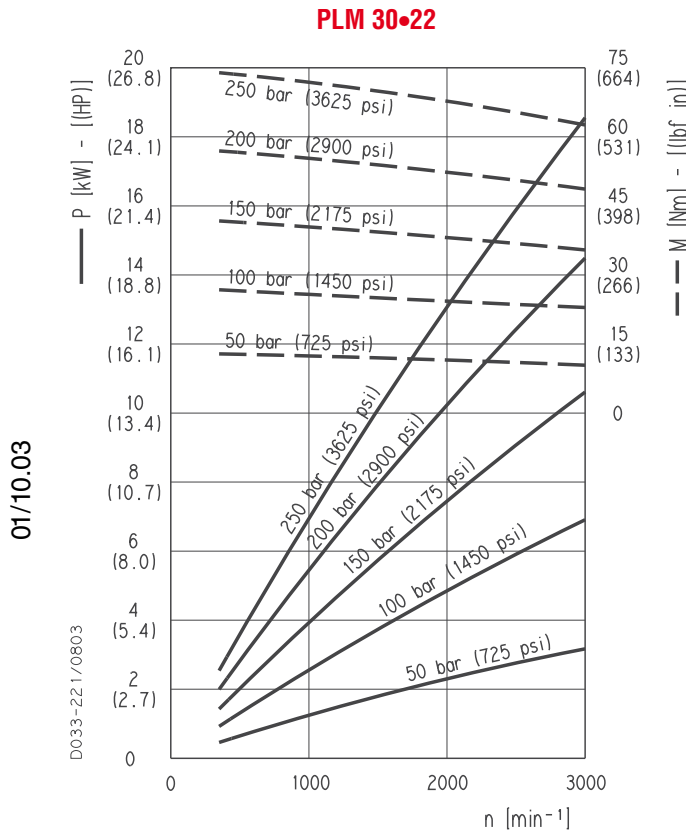

01/10.03

D033-221/0803

D033-222/0803

PLM 30

POLARIS 30 GEAR MOTORS PERFORMANCE CURVES

PLM 30•34

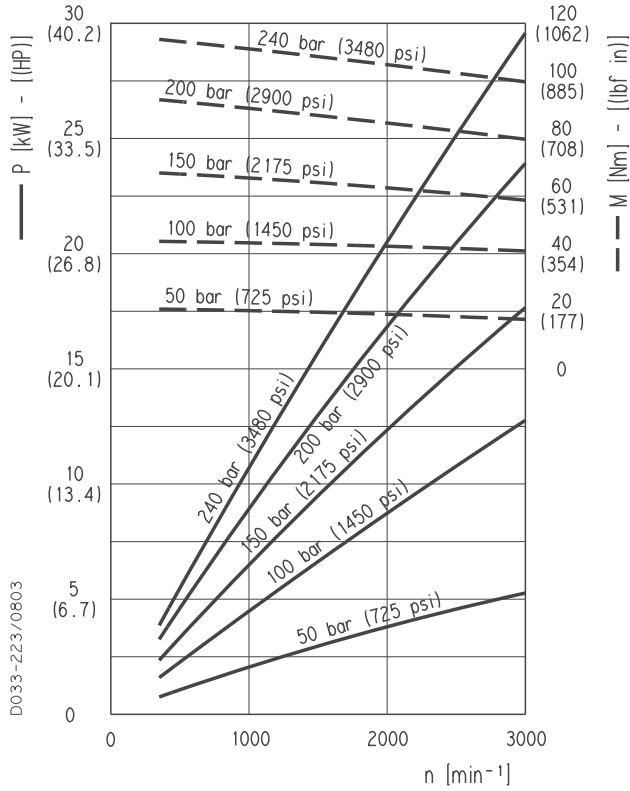

PLM 30•38

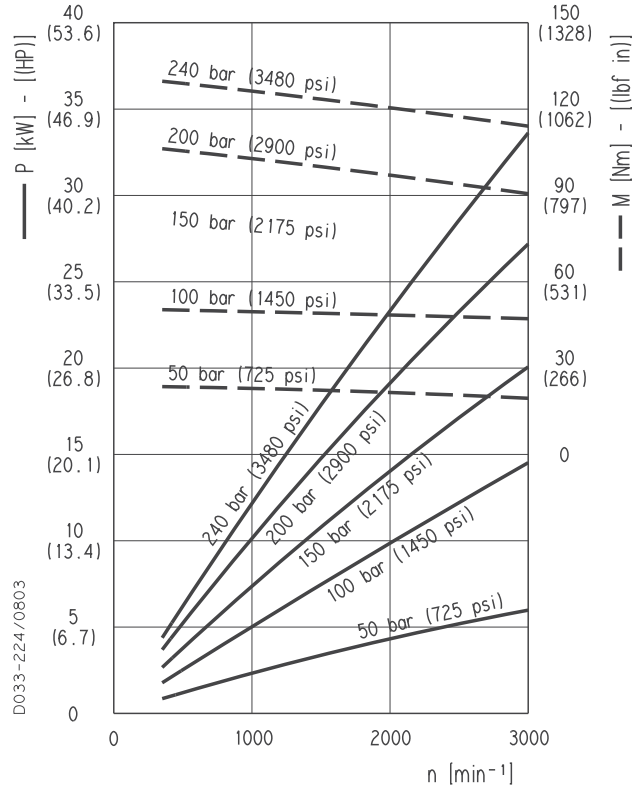

PLM 30•43

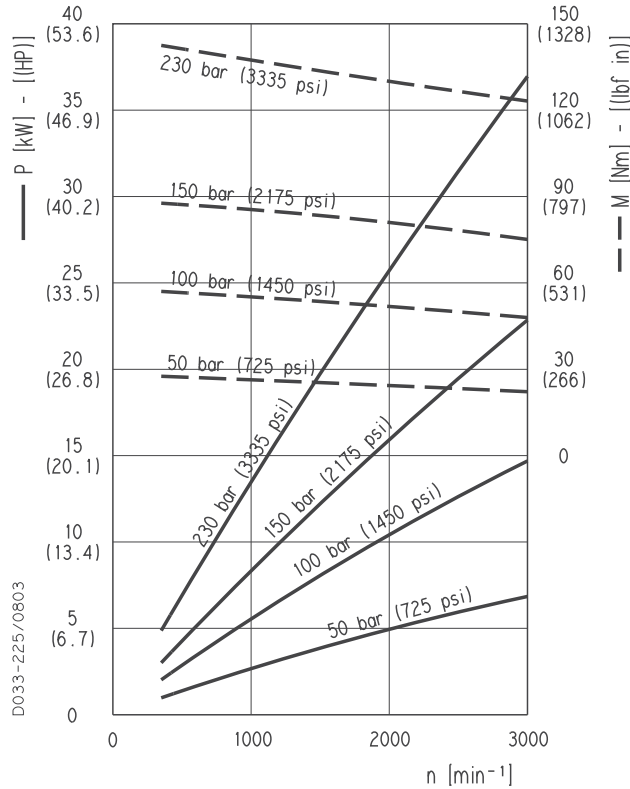

PLM 30•51

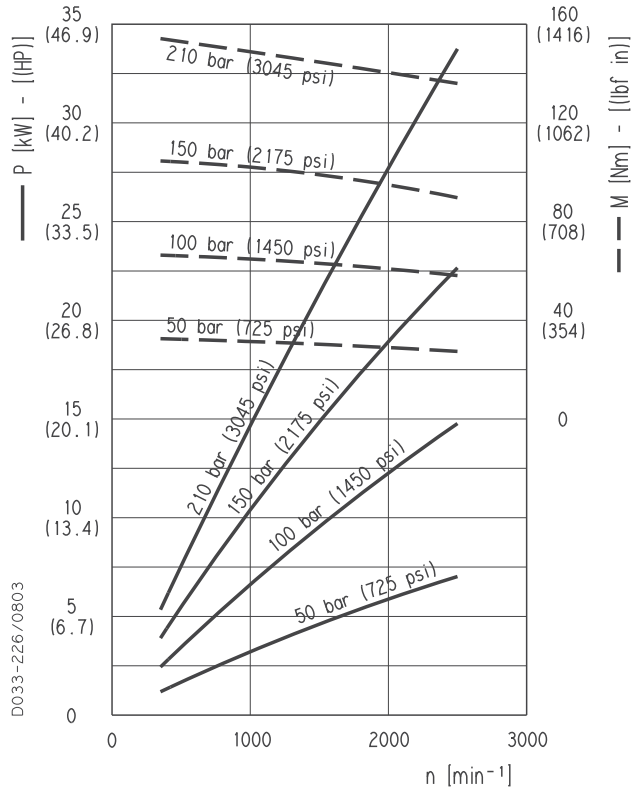

01/10.03

PLM 30

POLARIS 30 GEAR MOTORS PERFORMANCE CURVES

PLM 30•61

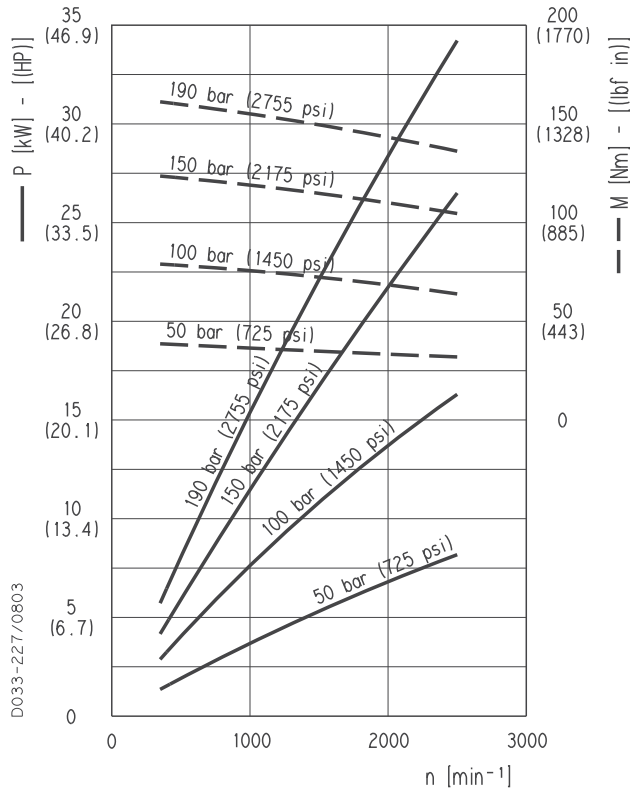

PLM 30•73

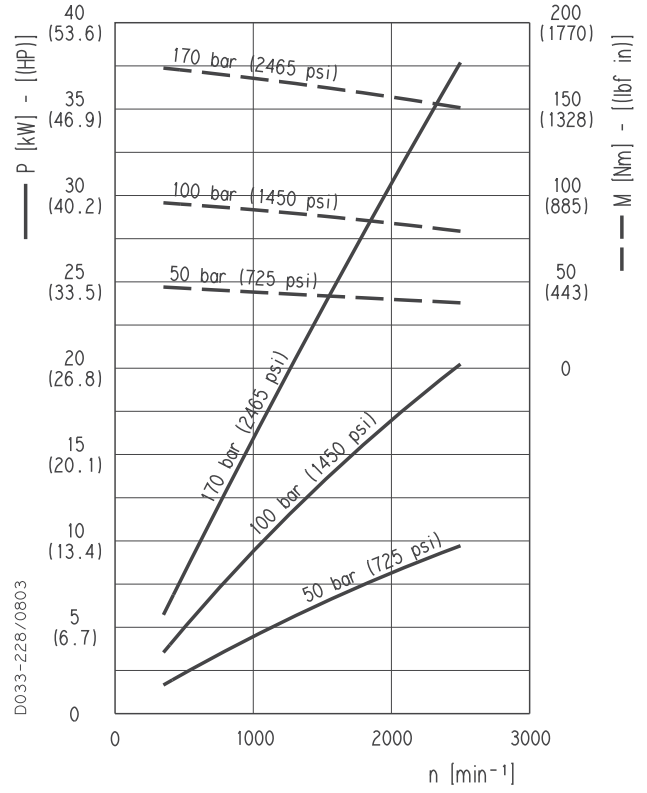

PLM 30•82

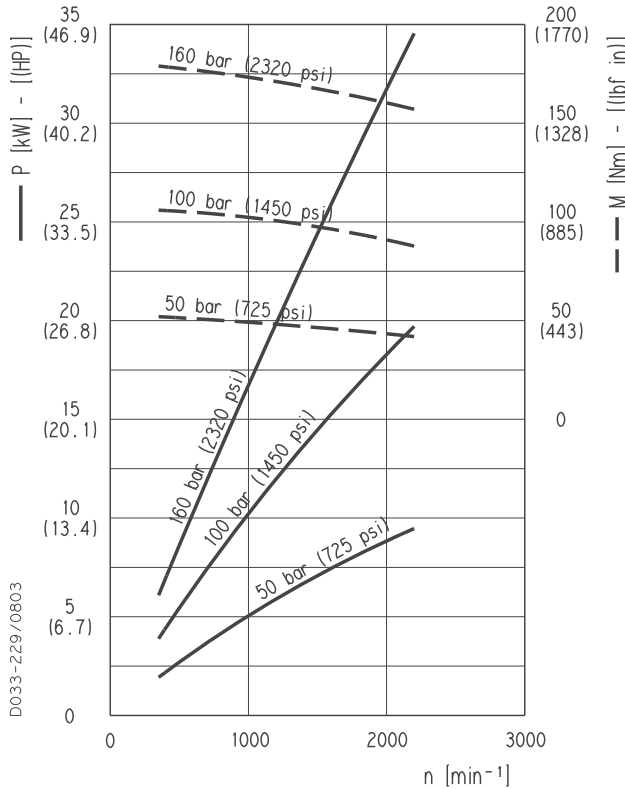

PLM 30•90

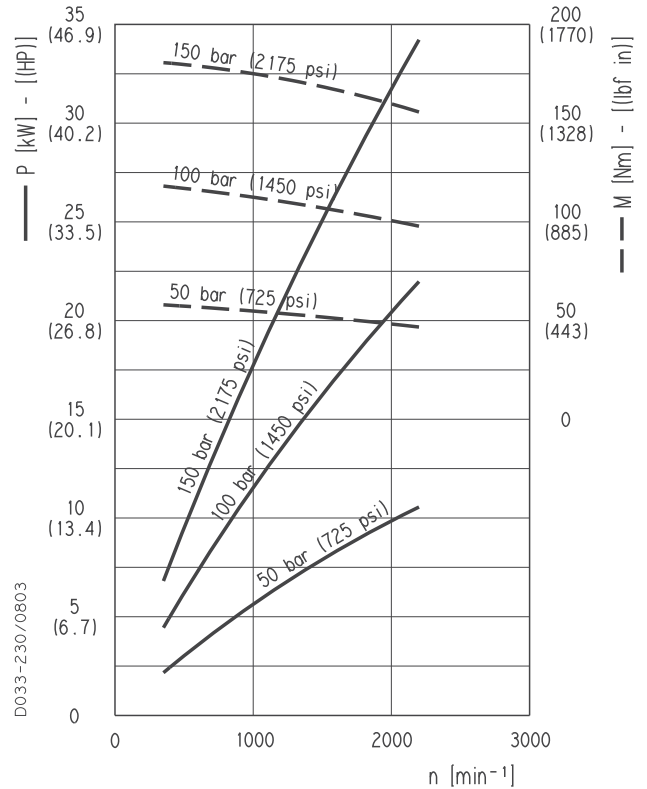

01/10.03

POLARIS 10

SINGLE UNITS SIDE PORTS

L

D033-180/0903

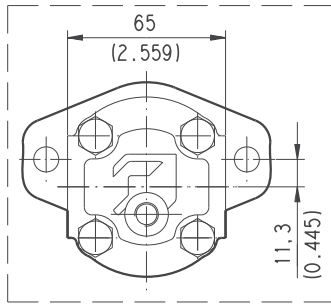

Reversible R

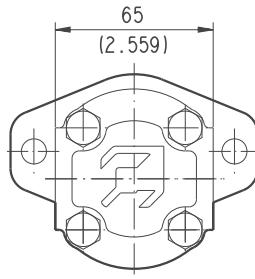

Single rotation S - D

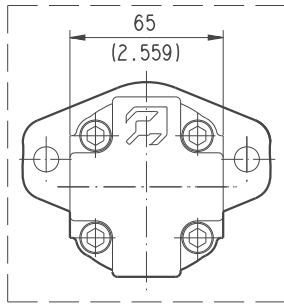
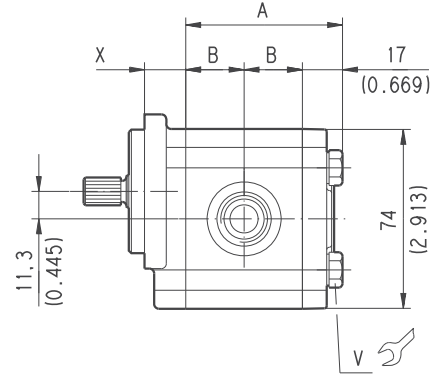

Reversible B

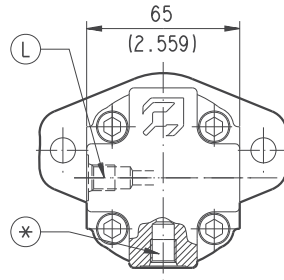

Reversible L

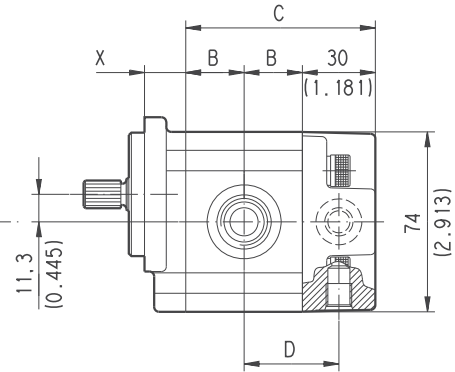

Replaces: 01/10.03

Mounting flange type version 0	X
	mm (inch)
E1	14 (0.5512)
E7	14 (0.5512)
E8	14 (0.5512)
B1	14 (0.5512)
K2	11,8 (0.4646)
S0	17 (0.6693)
R8	41 (1.6142)
R9	41 (1.6142)
W9	41 (1.6142)

- For single rotation S - D and reversible rotation R the rear cover is available in cast iron and aluminium.
For reversible rotation B and L the rear cover is in aluminium only.

DRAIN PORTS POSITION
L = Side * = Bottom

DRIVE SHAFTS: see page 52

MOUNTING FLANGE: see page 58 ÷ 60

PORTS: see page. 69 ÷ 74

Mounting flange material	Screw tightening torque
	Nm (lbf in)
Aluminium	V 25 ±2,5 (199 ÷ 243)
Cast iron	

Pump type	A	B	C	D
Motor type	mm (inch)	mm (inch)	mm (inch)	mm (inch)
PL. 10•1	52,2 (2.0551)	17,6 (0.6929)	65,2 (2.5669)	32,6 (1.2835)
PL. 10•1,5	53,8 (2.1181)	18,4 (0.7244)	66,8 (2.6299)	33,4 (1.3150)
PL. 10•2	55,4 (2.1811)	19,2 (0.7559)	68,4 (2.6929)	34,2 (1.3465)
PL. 10•2,5	57 (2.2441)	20 (0.7874)	70 (2.7559)	35 (1.3780)
PL. 10•3,15	59 (2.3228)	21 (0.8268)	72 (2.8346)	36 (1.4173)
PL. 10•4	61,8 (2.4331)	22,4 (0.8819)	74,8 (2.9449)	37,4 (1.4724)
PL. 10•5	65 (2.5591)	24 (0.9449)	78 (3.0709)	39 (1.5354)
PL. 10•5,8	67,6 (2.6614)	25,3 (0.9961)	80,6 (3.1732)	40,3 (1.5866)
PL. 10•6,3	69 (2.7165)	26 (1.0236)	82 (3.2283)	41 (1.6142)
PL. 10•8	74,5 (2.9331)	28,75 (1.1319)	87,5 (3.4449)	43,75 (1.7224)
PL. 10•10	81 (3.1890)	32 (1.2598)	94 (3.7008)	47 (1.8504)

○ 02/07.2006

POLARIS 10

SINGLE UNITS REAR PORTS

P

Replaces: 01/10.03

D033-181/0903

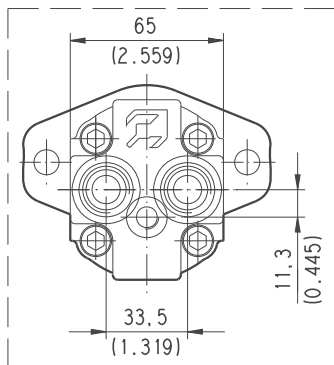

Reversible R

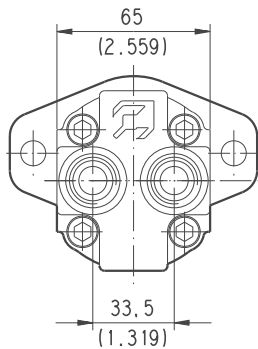

Single rotation S - D and Reversible B

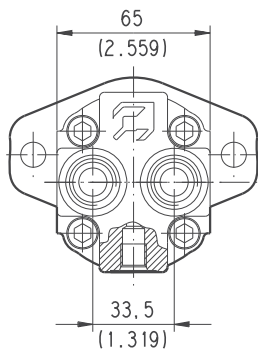

Reversible L

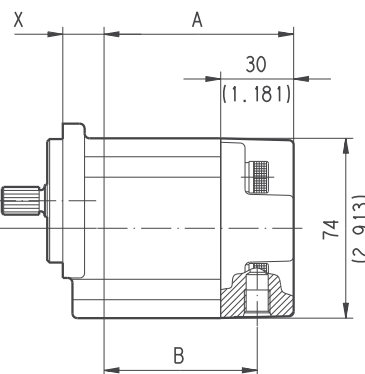
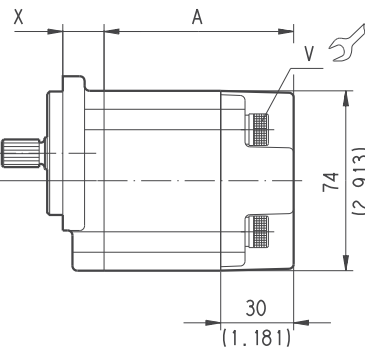

Mounting flange type version 0	X
	mm (inch)
E1	14 (0.5512)
E7	14 (0.5512)
E8	14 (0.5512)
B1	14 (0.5512)
K2	11,8 (0.4646)
S0	17 (0.6693)
R8	41 (1.6142)
R9	41 (1.6142)
W9	41 (1.6142)

● Rear cover in aluminium only.

DRIVE SHAFTS: see page 52
MOUNTING FLANGE: see page 58 ÷ 60
PORTS: see page 69 ÷ 74

Mounting flange material	Screw tightening torque Nm (lbf in)
	V
Aluminium	25 ±2,5 (199 ÷ 243)
Cast iron	

● 02/07.2006

Pump type Motor type	A	B
	mm (inch)	mm (inch)
PL. 10•1	65,2 (2.5669)	50,2 (1.9764)
PL. 10•1,5	66,8 (2.6299)	51,8 (2.0394)
PL. 10•2	68,4 (2.6929)	53,4 (2.0124)
PL. 10•2,5	70 (2.7559)	55 (2.1654)
PL. 10•3,15	72 (2.8346)	57 (2.2441)
PL. 10•4	74,8 (2.9449)	59,8 (2.3543)
PL. 10•5	78 (3.0709)	63 (2.4803)
PL. 10•5,8	80,6 (3.1732)	65,6 (2.5827)
PL. 10•6,3	82 (3.2283)	67 (2.6378)
PL. 10•8	87,5 (3.4449)	72,5 (2.8543)
PL. 10•10	94 (3.7008)	79 (3.1102)

POLARIS 20

SINGLE UNITS SIDE PORTS

L

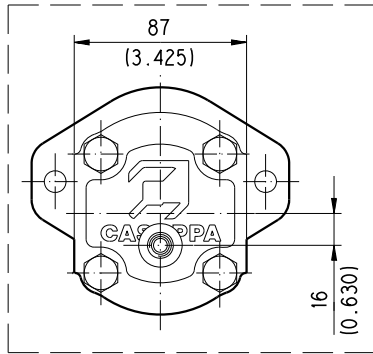

Reversible R

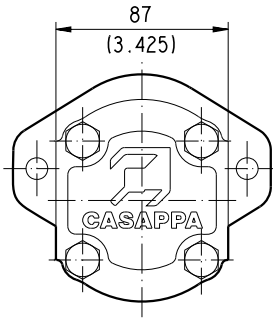

Single rotation S - D and Reversible B

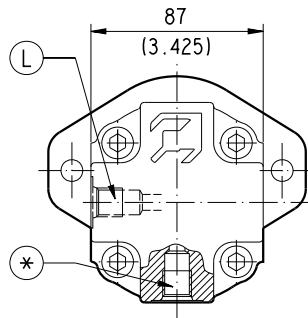
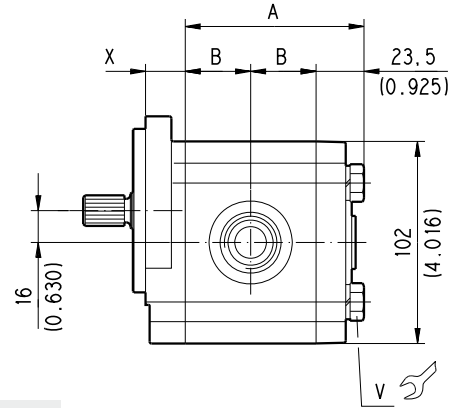

Reversible L

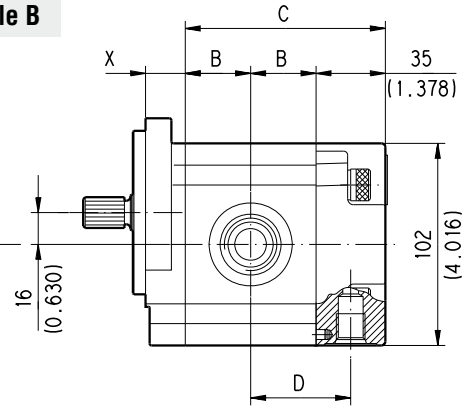

D033-182/0903

Replaces: 01/10.03

Mounting flange type version 0	X
	mm (inch)
E2	18 (0.7087)
B2	18,8 (0.7402)
B4	16 (0.6299)
B5	16 (0.6299)
B6	17,7 (0.6969)
S1	20 (0.7874)
S2	20 (0.7874)
S9	20 (0.7874)
S5	20 (0.7874)
W8	32,1 (1.2638)

○ For single rotation S - D and reversible rotation R and B the rear cover is available in cast iron and aluminium. For reversible rotation L the rear cover is in aluminium only.

DRAIN PORTS POSITION
L = Side * = Bottom

DRIVE SHAFTS: see page 53 ÷ 55
MOUNTING FLANGE: see page 61 ÷ 65
PORTS: see page. 69 ÷ 74

Mounting flange material	Screw tightening torque Nm (lbf in)
	V
Aluminium	45 ^{±4,5} (358 ÷ 438)
Cast iron	70 ^{±7} (558 ÷ 682)

Pump type Motor type	A	B	C	D
	mm (inch)	mm (inch)	mm (inch)	mm (inch)
PL. 20•4	75 (2.9528)	25,75 (1.0138)	86,5 (3.4055)	43,25 (1.7028)
PL. 20•6,3	77,5 (3.0512)	27 (1.0630)	89 (3.5039)	44,5 (1.7520)
PL. 20•7,2	78,5 (3.0905)	27,5 (1.0826)	90 (3.5433)	45 (1.7716)
PL. 20•8	80 (3.1496)	28,25 (1.1122)	91,5 (3.6024)	45,75 (1.8012)
PL. 20•9	81,3 (3.2008)	28,9 (1.1378)	92,8 (3.6535)	46,4 (1.8268)
PL. 20•10,5	84 (3.3070)	30,25 (1.1909)	95,5 (3.7598)	47,75 (1.8799)
PL. 20•11,2	84,5 (3.3268)	30,5 (1.2008)	96 (3.7795)	48 (1.8898)
PL. 20•14	89,5 (3.5236)	33 (1.2992)	101 (3.9764)	50,5 (1.9882)
PL. 20•16	93 (3.6614)	34,75 (1.3681)	104,5 (4.1142)	52,25 (2.0571)
PL. 20•19	96,4 (3.7952)	36,45 (1.4350)	107,9 (4.2480)	53,45 (2.1043)
PL. 20•20	99,5 (3.9173)	38 (1.4961)	111 (4.3701)	55,5 (2.1850)
PL. 20•24,5	105,1 (4.1378)	40,8 (1.6063)	116,6 (4.5905)	58,3 (2.2953)
PL. 20•25	107,5 (4.2323)	42 (1.6535)	119 (4.6850)	59,5 (2.3425)
PL. 20•27,8	110,2 (4.3386)	43,35 (1.7067)	121,7 (4.7913)	60,85 (2.3957)
PL. 20•31,5	117,5 (4.6260)	47 (1.8504)	129 (5.0787)	64,5 (2.5394)

○ 02/07.2006

POLARIS 20

SINGLE UNITS REAR PORTS

P

Replaces: 01/10.03

D033-183/0903

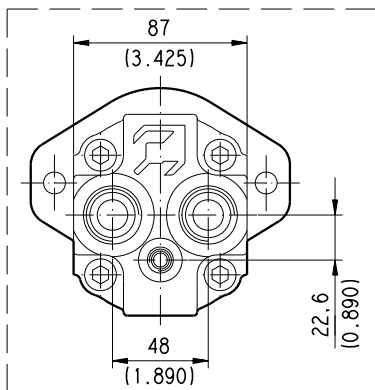

Reversible R

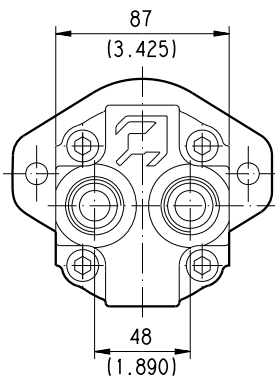

Single rotation S - D and Reversible B

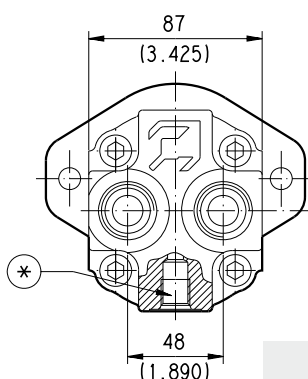
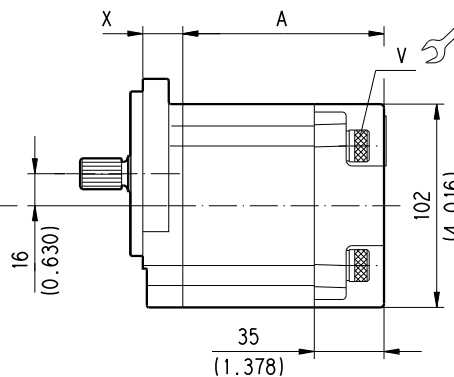

Reversible L

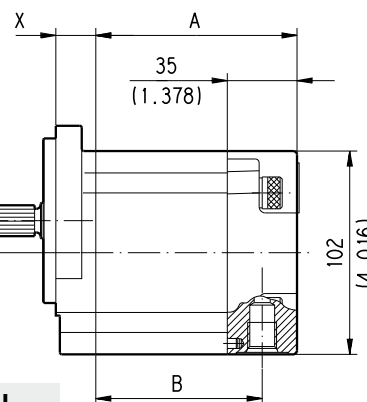

Mounting flange type version 0	X
	mm (inch)
E2	18 (0.7087)
B2	18,8 (0.7402)
B4	16 (0.6299)
B5	16 (0.6299)
B6	17,7 (0.6969)
S1	20 (0.7874)
S2	20 (0.7874)
S9	20 (0.7874)
S5	20 (0.7874)
W8	32,1 (1.2638)

● Rear cover in aluminium only.

DRAIN PORTS POSITION
L = Side * = Bottom

DRIVE SHAFTS: see page 53 ÷ 55

MOUNTING FLANGE: see page 61 ÷ 65

PORTS: see page. 69 ÷ 74

Mounting flange material	Screw tightening torque
	Nm (lbf in)
	V
Aluminium	45 ^{±4,5} (358 ÷ 438)
Cast iron	70 ^{±7} (558 ÷ 682)

● 02/07.2006

Pump type Motor type	A	B
	mm (inch)	mm (inch)
PL. 20•4	86,5 (3.4055)	69 (2.71765)
PL. 20•6,3	89 (3.5039)	71,5 (2.8150)
PL. 20•7,2	90 (3.5433)	72,5 (2.8543)
PL. 20•8	91,5 (3.6024)	74 (2.9134)
PL. 20•9	92,8 (3.6535)	75,3 (2.9646)
PL. 20•10,5	95,5 (3.7598)	78 (3.0708)
PL. 20•11,2	96 (3.7795)	78,5 (3.0906)
PL. 20•14	101 (3.9764)	83,5 (3.2784)
PL. 20•16	104,5 (4.1142)	87 (3.4252)
PL. 20•19	107,9 (4.2480)	89,9 (3.5393)
PL. 20•20	111 (4.3701)	93,5 (3.6811)
PL. 20•24,5	116,6 (4.5905)	99,1 (3.9016)
PL. 20•25	119 (4.6850)	101,5 (3.9961)
PL. 20•27,8	121,7 (4.7913)	104,2 (4.1024)
PL. 20•31,5	129 (5.0787)	111,5 (4.3898)

POLARIS 30

SINGLE UNITS SIDE PORTS

L

D033-184/0903

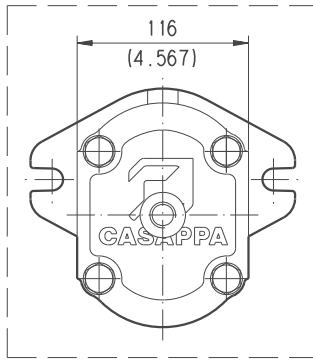

Reversible R

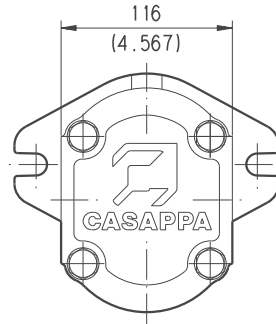

Single rotation S - D

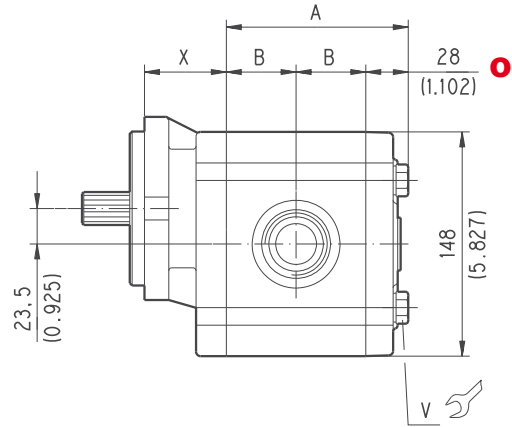

Replaces: 02/07.2006

Mounting flange type version 0	X
	mm (inch)
E3	24 (0.945)
E4	25 (0.984)
B3	28 (1.102)
S5	54 (2.1260)
U3	20,8 (0.819)

Rear cover in cast iron only.

DRIVE SHAFTS:
see page 56 and page 57
MOUNTING FLANGE:
see page 66 ÷ 68
PORTS: see page. 69 ÷ 74

Mounting flange material	Screw tightening torque Nm (lbf in)
	V
Cast iron	100 ±10 (797 ÷ 974)

Pump type Motor type	A	B
	mm (inch)	mm (inch)
PL. 30•22	106 (4.1732)	39 (1.5354)
PL. 30•27	109 (4.2913)	40,5 (1.5945)
PL. 30•34	114 (4.4882)	43 (1.6929)
PL. 30•38	117 (4.6063)	44,5 (1.7520)
PL. 30•43	120 (4.7244)	46 (1.8110)
PL. 30•51	125 (4.9212)	48,5 (1.9094)
PL. 30•61	131 (5.1575)	51,5 (2.0276)
PL. 30•73	139 (5.4724)	55,5 (2.1850)
PL. 30•82	144 (5.6693)	58 (2.2835)
PL. 30•90	150 (5.9055)	61 (2.4016)

O 03/02.2012

MULTIPLE PUMPS

POLARIS series pumps can be coupled together in combination. Where the input power requirements of each section varies, that with the greater requirement must be at the drive shaft end, and progressively smaller to the rear.

Features and performances are the same as the corresponding single pumps, but pressures must be limited by the transmissible torque of the drive and connecting shafts. To have appropriate data, use the formula below.

The maximum rotational speed is that of the lowest rated speed of the single units incorporated.

Available with common inlet and separated stages. For more information please consult our technical sales department.

Replaces: 01/10.03

M	lbf in [Nm]	Torque
V	in ³ /rev [cm ³ /rev]	Displacement
Δp	psi [bar]	Pressure
$\eta_{hm} = \eta_m (V, \Delta p, n)$	($\approx 0,88$)	Hydro-mechanical efficiency

$$M = \frac{M_{theor.}}{\eta_{hm}} \quad [Nm]$$

$$M_{theor.} = \frac{\Delta p \text{ (bar)} \cdot V \text{ (cm}^3\text{/rev)}}{62,83}$$

DRIVE SHAFT SELECTION

The torque absorbed from the shaft of the first pump results from the sum of the torques due to all single stages. The achieved value must not exceed the maximum torque limit given for the shaft of the first pump. Diagrams providing approximate selection data will be found on page 38.

03/02.2012

Example

Let us consider a double pump PLP20•14 + PLP20•4. If we suppose that we have to work with the first pump at a pressure of 2900 psi (200 bar) and the second pump at a pressure of 2175 psi (150 bar), the graph (2) shows that the torque absorbed by PLP20•14 is 469 lbf in (53 Nm) and the PLP20•4 absorbs 115 lbf in (13 Nm) (acceptable value because it doesn't exceed the maximum drive shaft torque that is 973 lbf in (110 Nm), see page 40). The torque to be transmitted by the first drive shaft will thus be 469+115= 584 lbf in (53+13= 66 Nm), this value must not exceed the shaft's maximum rated value.

ABSORBED TORQUE

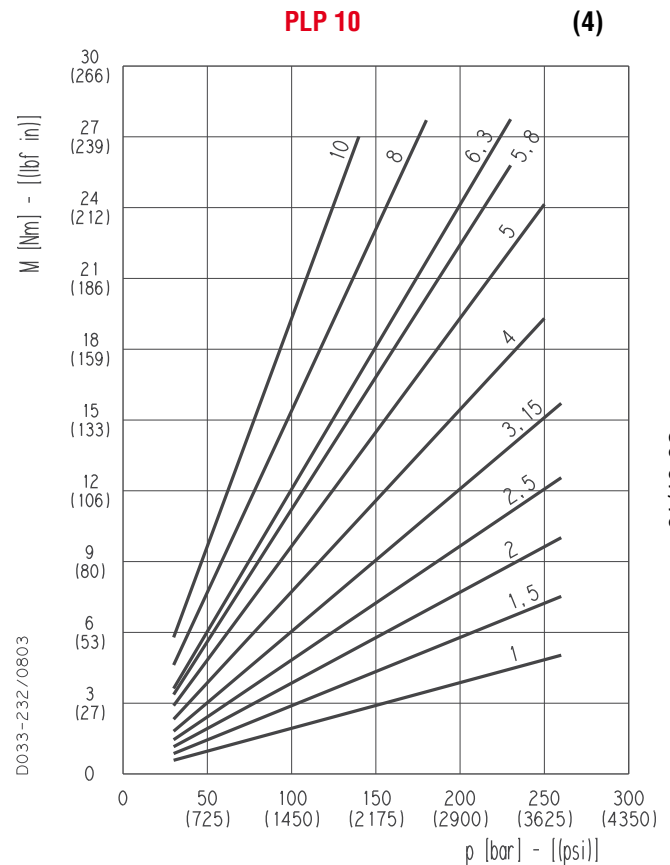
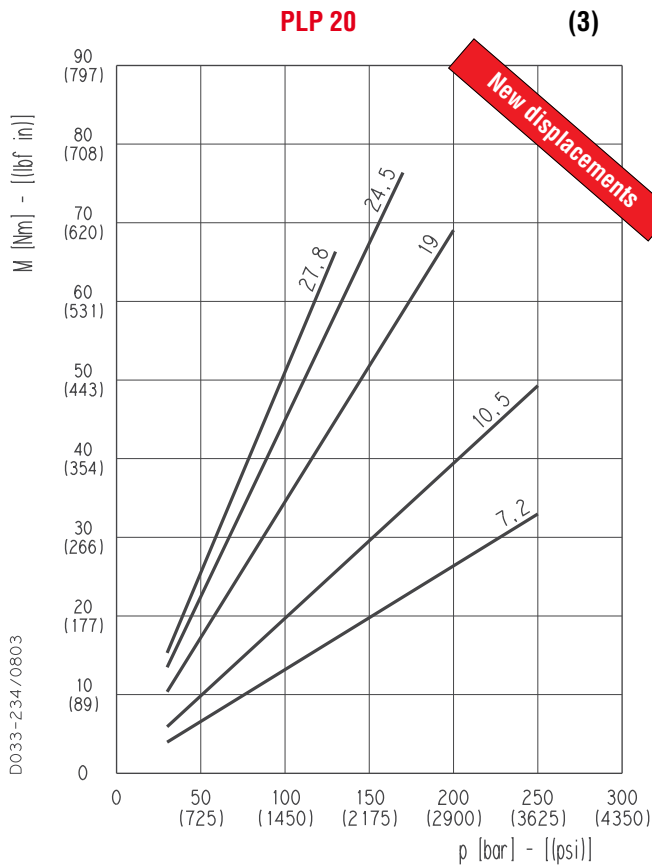
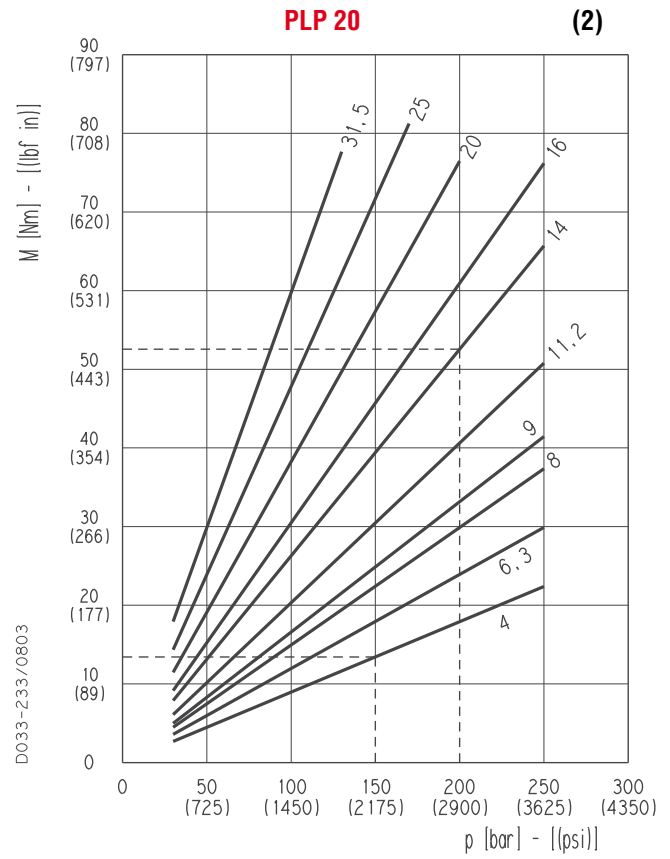
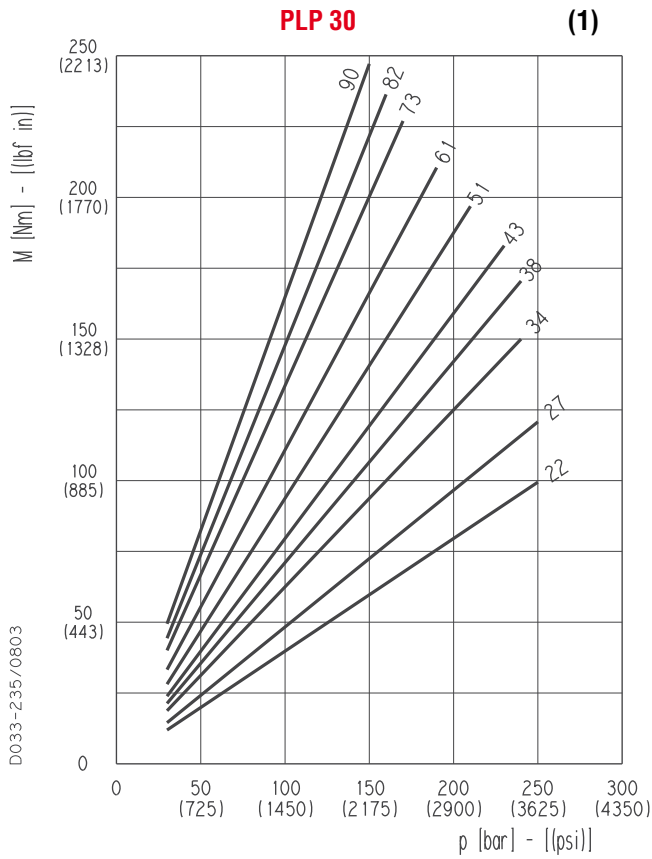

01/10.03

COMMON INLET - PORTS POSITION

PLP

Replaces: 01/10.03

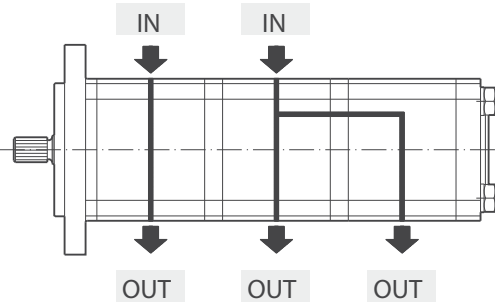
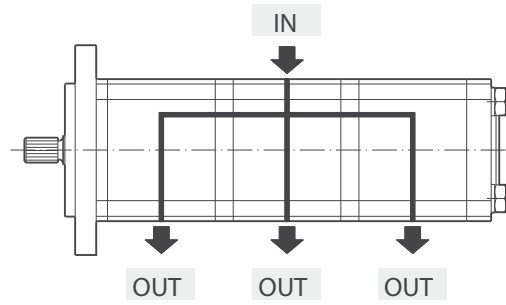
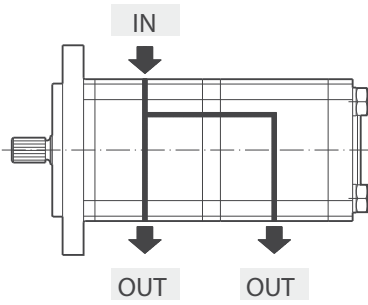

Reduced inlets provide overall systems savings by reducing the cost of redundant inlet hose and fittings.

For other combinations please consult our sales department.

MULTIPLE PUMPS COMBINATION

PLP 10

Polaris 10/10	STANDARD VERSION	V6
Polaris 10/10	COMMON INLET VERSION	V7

02/07.2006

D033-112/0603

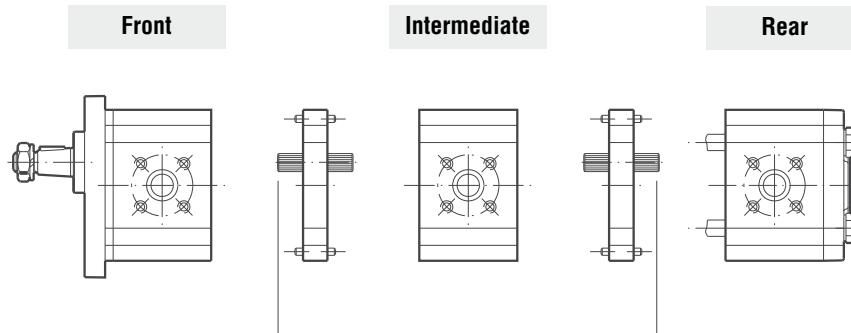

88 MAX 30 Nm (266 lbf in)

88 MAX 30 Nm (266 lbf in)

MULTIPLE PUMPS COMBINATION

PLP 20

Polaris 20/20	STANDARD VERSION	S6
Polaris 20/20	COMMON INLET VERSION	S7

D033-106/0603

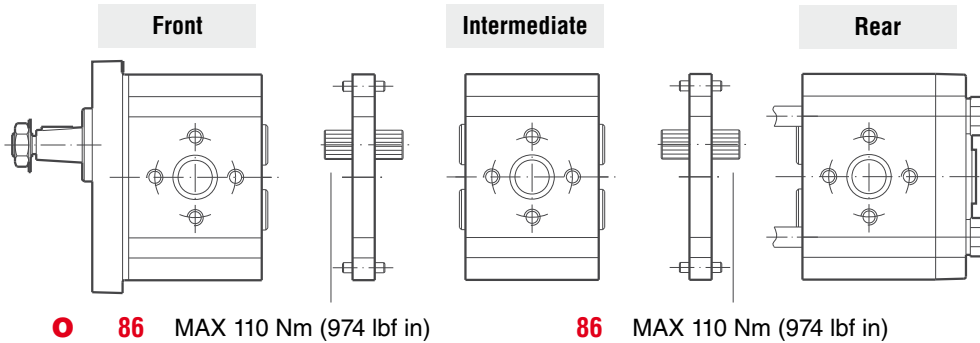

Replaces: 01/10.03

Polaris 20/20	SEPARATED STAGES VERSION	Z6
----------------------	---------------------------------	-----------

D033-110/0603

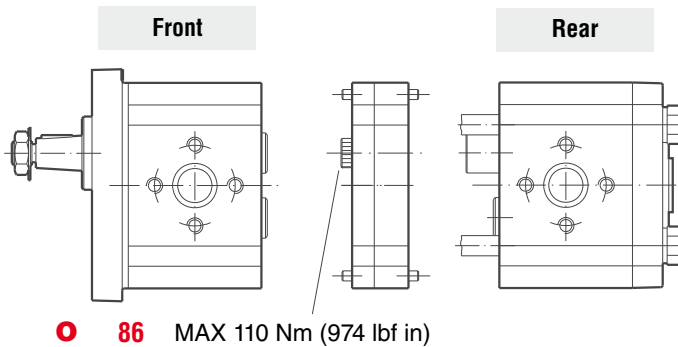

Polaris 20/10	STANDARD VERSION	T6
Polaris 20/10	COMMON INLET VERSION	T7

D033-107/0603

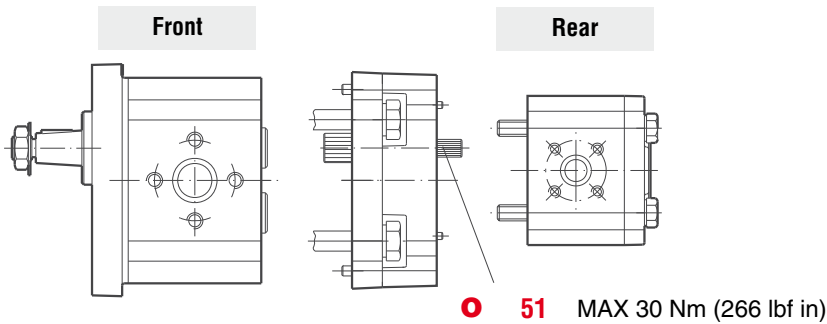

Polaris 20/10	SEPARATED STAGES VERSION	Z6
----------------------	---------------------------------	-----------

D033-111/0603

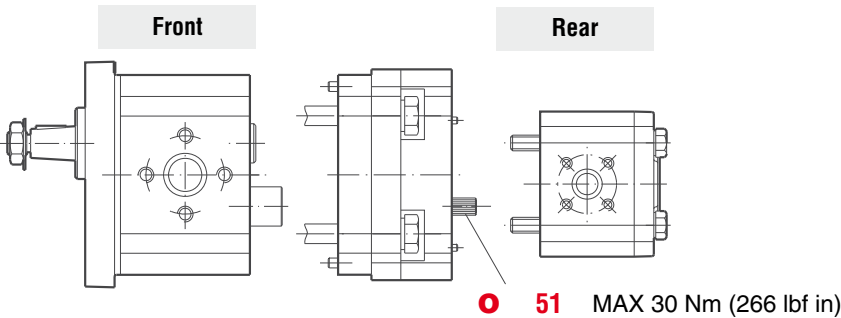

02/07.2006

MULTIPLE PUMPS COMBINATION

PLP 30

Polaris 30/30

STANDARD VERSION

M6

Replaces: 01/10.03

D033-100/0603

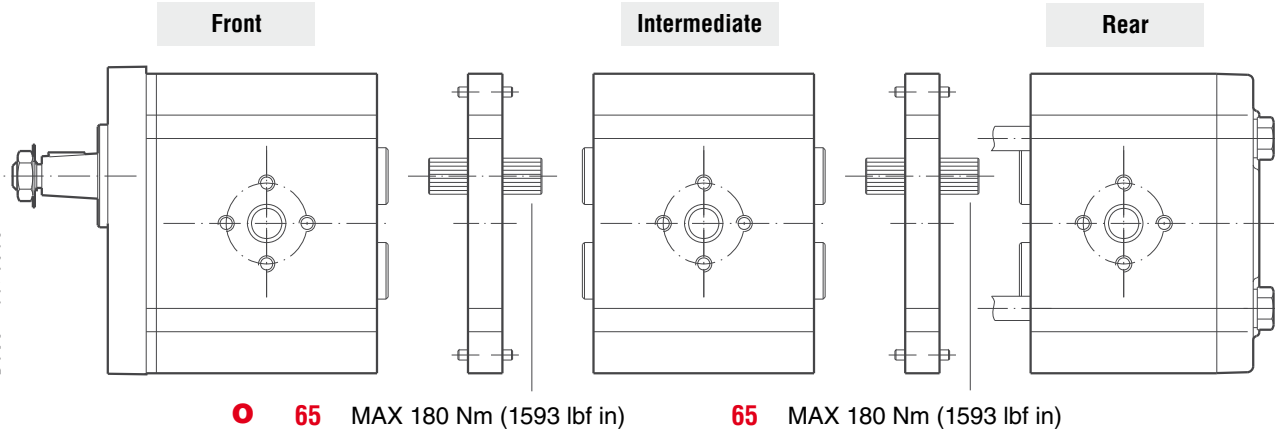

Polaris 30/20

STANDARD VERSION

N6

Polaris 30/20

COMMON INLET VERSION

N7

D033-101/0603

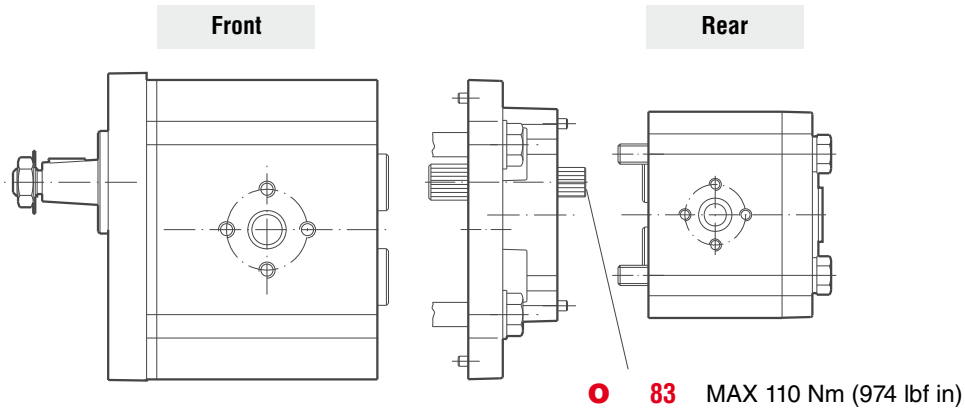

Polaris 30/20

SEPARATED STAGES VERSION

Z6

02/07.2006

D033-105/0603

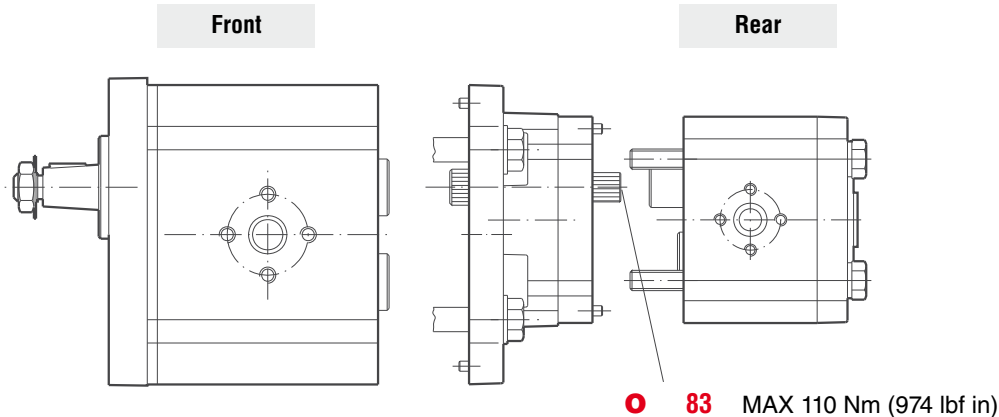

MULTIPLE PUMPS COMBINATION

PLP 30

Polaris 30/10	STANDARD VERSION	Q6
Polaris 30/10	COMMON INLET VERSION	Q7

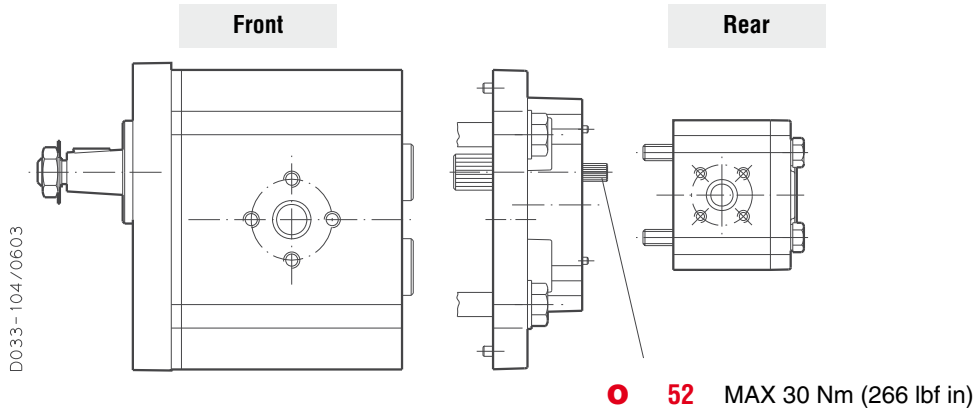

Replaces: 01/10.03

02/07.2006

POLARIS 10

MULTIPLE PUMPS

PLP 10/10

Replaces: 01/10.03

D033-190/0903

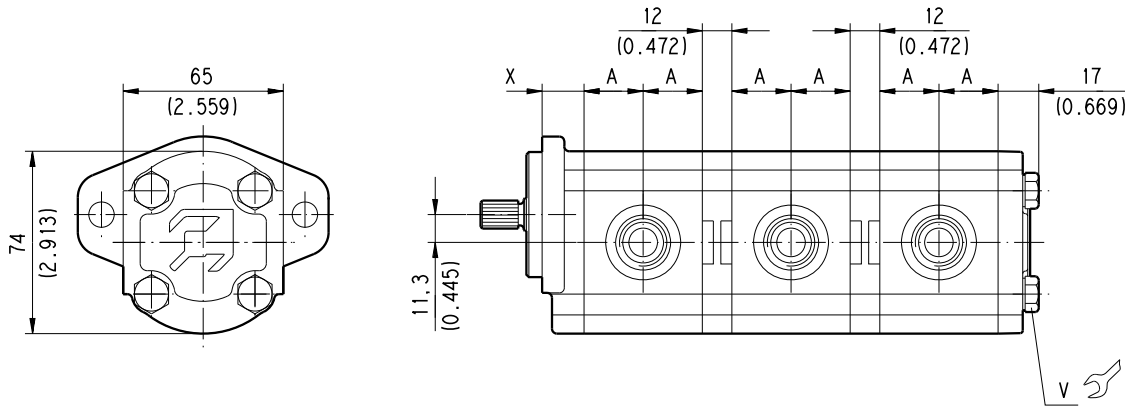

○ Rear cover available in cast iron and aluminium.

DRIVE SHAFTS: see page 52

MOUNTING FLANGE: see page 58 ÷ 60

PORTS: see page. 69 ÷ 74

Mounting flange material	○ Screw tightening torque Nm (lbf in)
	V
Aluminium	25 ^{±2,5} (199 ÷ 243)
Cast iron	

○ 02/07.2006

Pump type	A mm (inch)
PLP 10•1	17,6 (0.6929)
PLP 10•1,5	18,4 (0.7244)
PLP 10•2	19,2 (0.7559)
PLP 10•2,5	20 (0.7874)
PLP 10•3,15	21 (0.8268)
PLP 10•4	22,4 (0.8819)
PLP 10•5	24 (0.9449)
PLP 10•5,8	25,3 (0.9961)
PLP 10•6,3	26 (1.0236)
PLP 10•8	28,75 (1.1319)
PLP 10•10	32 (1.2598)

Mounting flange type version 0	X mm (inch)
E1	14 (0.5512)
E7	14 (0.5512)
E8	14 (0.5512)
B1	14 (0.5512)
K2	11,8 (0.4646)
S0	17 (0.6693)
R8	41 (1.6142)
R9	41 (1.6142)
W9	41 (1.6142)

POLARIS 20

MULTIPLE PUMPS

PLP 20

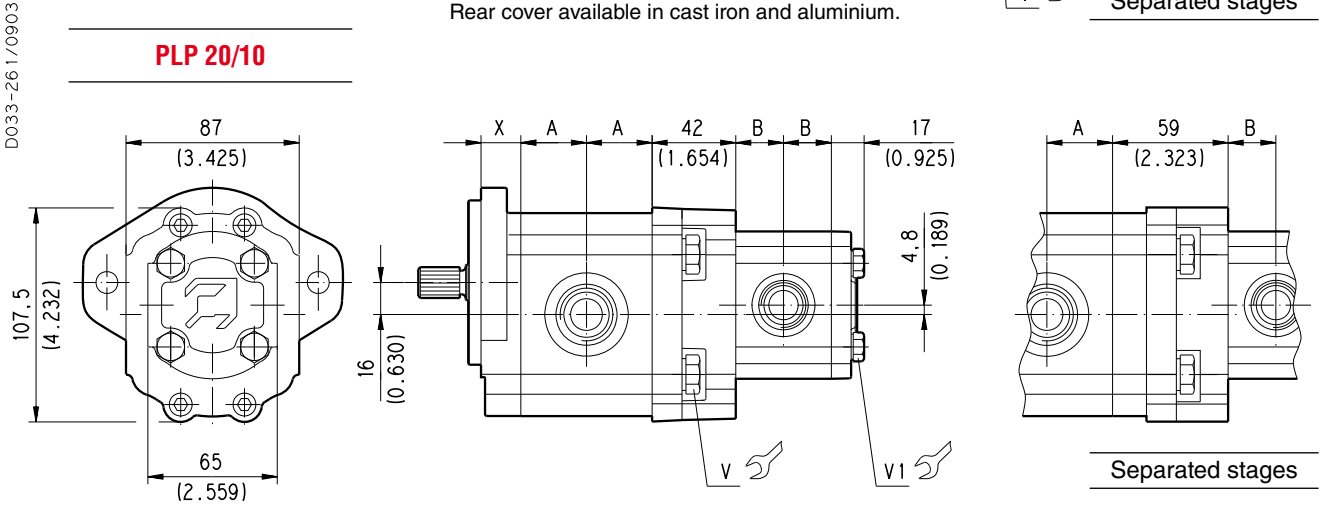
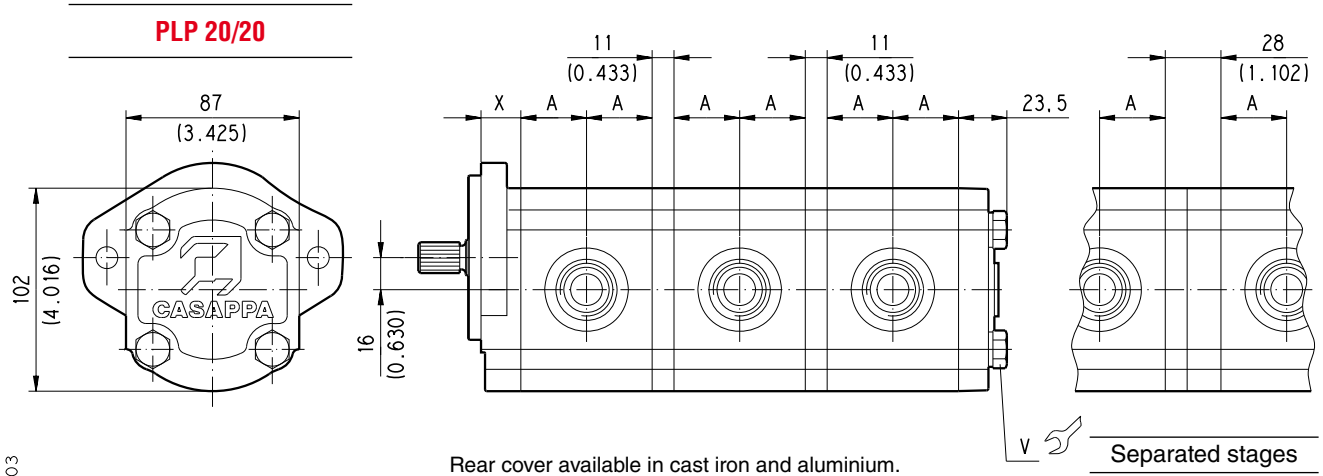

Replaces: 01/10.03

○ Rear cover available in cast iron and aluminium.

DRIVE SHAFTS:
see page 53 ÷ 55

MOUNTING FLANGE:
see page 61 ÷ 65

PORTS:
see page. 69 ÷ 74

○ Screw tightening torque
Nm (lbf in)

Pump type	A
	mm (inch)
PLP 20•4	25,75 (1.0138)
PLP 20•6,3	27 (1.0630)
PLP 20•7,2	27,5 (1.0826)
PLP 20•8	28,25 (1.1122)
PLP 20•9	28,9 (1.1378)
PLP 20•10,5	30,25 (1.1909)
PLP 20•11,2	30,5 (1.2008)
PLP 20•14	33 (1.2992)
PLP 20•16	34,75 (1.3681)
PLP 20•19	36,45 (1.4350)
PLP 20•20	38 (1.4961)
PLP 20•24,5	40,8 (1.6063)
PLP 20•25	42 (1.6535)
PLP 20•27,5	43,35 (1.7067)
PLP 20•31,5	47 (1.8504)

Mounting flange material	Screw tightening torque	
	V	V1
Aluminium	45 ±4,5 (358 ÷ 438)	25 ±2,5 (199 ÷ 243)
Cast iron	70 ±7 (558 ÷ 682)	

Pump type	B
	mm (inch)
PLP 10•1	17,6 (0.6929)
PLP 10•1,5	18,4 (0.7244)
PLP 10•2	19,2 (0.7559)
PLP 10•2,5	20 (0.7874)
PLP 10•3,15	21 (0.8268)
PLP 10•4	22,4 (0.8819)
PLP 10•5	24 (0.9449)
PLP 10•5,8	25,3 (0.9961)
PLP 10•6,3	26 (1.0236)
PLP 10•8	28,75 (1.1319)
PLP 10•10	32 (1.2598)

Mounting flange type version 0	X
	mm (inch)
E2	18 (0.7087)
B2	18,8 (0.7402)
B4	16 (0.6299)
B5	16 (0.6299)
B6	17,7 (0.6969)
S1	20 (0.7874)
S2	20 (0.7874)
S9	20 (0.7874)
S5	20 (0.7874)
W8	32,1 (1.2638)

○ 02/07.2006

POLARIS 30

MULTIPLE PUMPS

PLP30

Replaces: 01/10.03

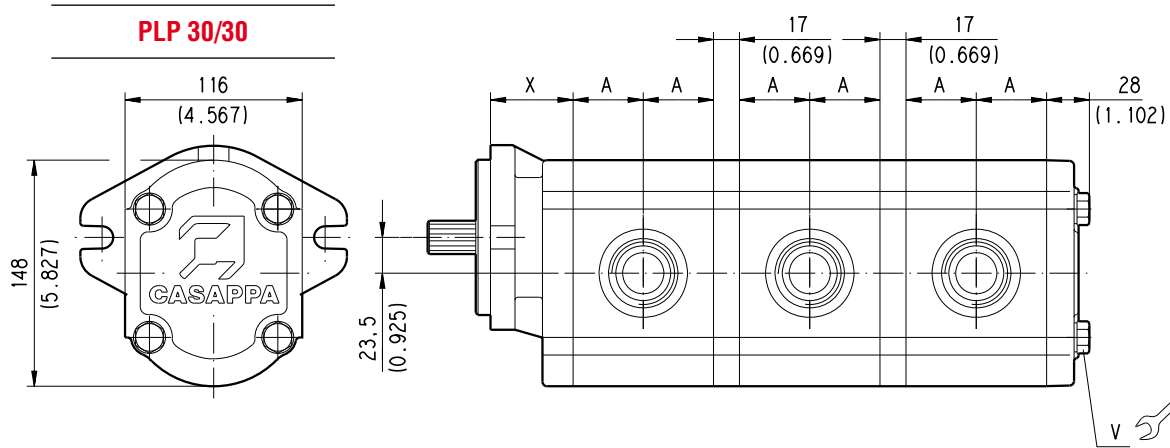

○ Rear cover in cast iron only.

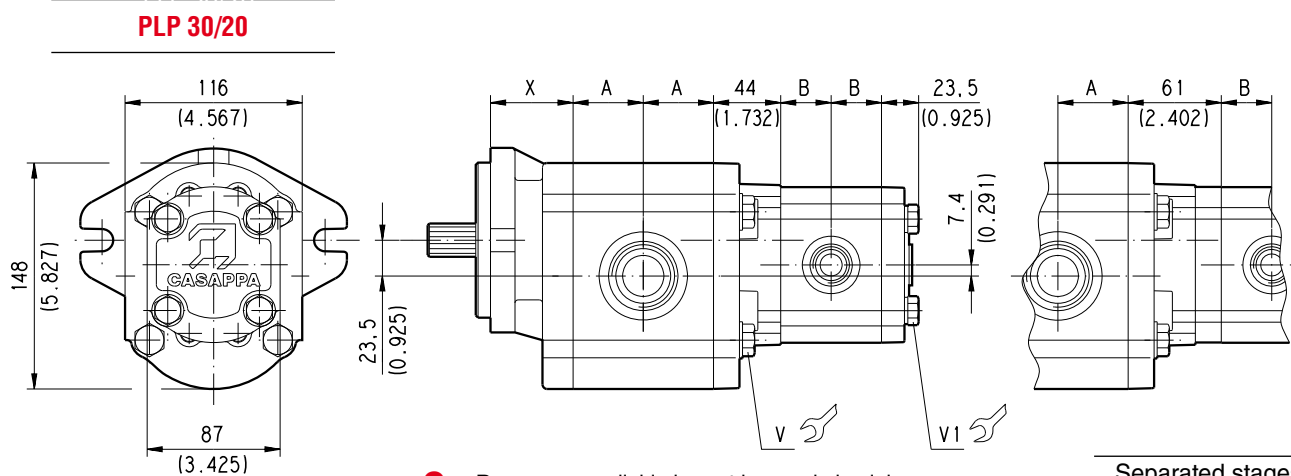

○ Rear cover available in cast iron and aluminium.

Separated stages

D033-260/0903

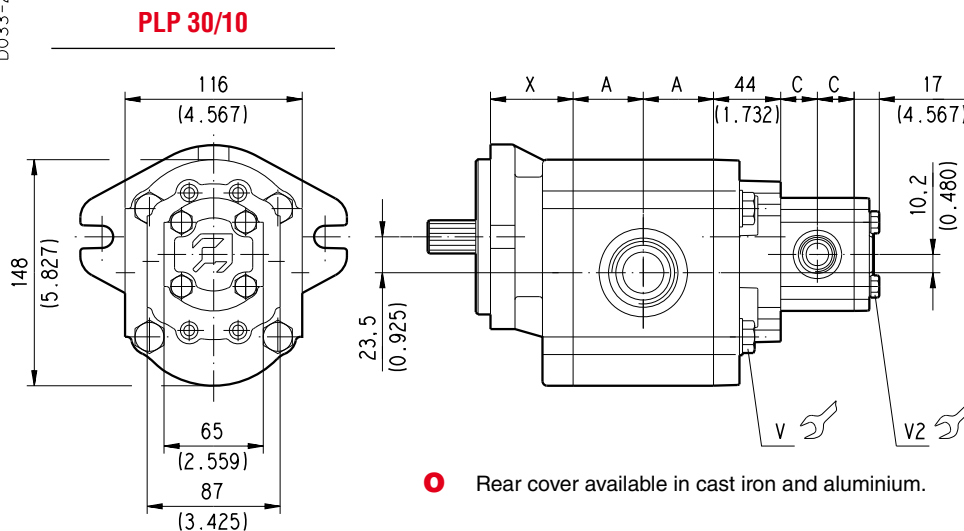

○ Rear cover available in cast iron and aluminium.

○ 02/07.2006

POLARIS 30
MULTIPLE PUMPS
PLP 30

Pump type	A
	mm (inch)
PLP 30•22	39 (1.5354)
PLP 30•27	40,5 (1.5945)
PLP 30•34	43 (1.6929)
PLP 30•38	44,5 (1.7520)
PLP 30•43	46 (1.8110)
PLP 30•51	48,5 (1.9094)
PLP 30•61	51,5 (2.0276)
PLP 30•73	55,5 (2.1850)
PLP 30•82	58 (2.2835)
PLP 30•90	61 (2.4016)

Pump type	B
	mm (inch)
PLP 20•4	25,75 (1.0138)
PLP 20•6,3	27 (1.0630)
PLP 20•7,2	27,5 (1.0826)
PLP 20•8	28,25 (1.1122)
PLP 20•9	28,9 (1.1378)
PLP 20•10,5	30,25 (1.1909)
PLP 20•11,2	30,5 (1.2008)
PLP 20•14	33 (1.2992)
PLP 20•16	34,75 (1.3681)
PLP 20•19	36,45 (1.4350)
PLP 20•20	38 (1.4961)
PLP 20•24,5	40,8 (1.6063)
PLP 20•25	42 (1.6535)
PLP 20•27,5	43,35 (1.7067)
PLP 20•31,5	47 (1.8504)

Pump type	C
	mm (inch)
PLP 10•1	17,6 (0.6929)
PLP 10•1,5	18,4 (0.7244)
PLP 10•2	19,2 (0.7559)
PLP 10•2,5	20 (0.7874)
PLP 10•3,15	21 (0.8268)
PLP 10•4	22,4 (0.8819)
PLP 10•5	24 (0.9449)
PLP 10•5,8	25,3 (0.9961)
PLP 10•6,3	26 (1.0236)
PLP 10•8	28,75 (1.1319)
PLP 10•10	32 (1.2598)

Replaces: 01/10.03

 DRIVE SHAFTS:
 see page 56 and page 57

 MOUNTING FLANGE:
 see page 66 ÷ 68

 PORTS:
 see page. 69 ÷ 74

Mounting flange type version 0	X
	mm (inch)
E3	24 (0.945)
E4	25 (0.984)
B3	28 (1.102)
S5	54 (2.1260)
U3	20,8 (0.819)

Mounting flange material	○ Screw tightening torque Nm (lbf in)		
	V	V1	V2
	Aluminium	45 ^{±4,5} (358 ÷ 438)	25 ^{±2,5} (199 ÷ 243)
Cast iron	100 ^{±10} (797 ÷ 974)		

○ 02/07.2006

VERSIONS

For each version, the possible combination between drive shafts and mounting flanges are shown on pages 58 ÷ 68.

VERSION 0		
Available for group:		
10	20	30

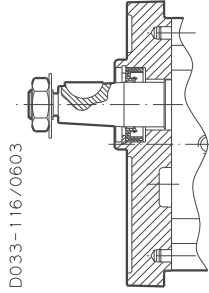

Version for applications without radial and axial load on the drive shaft.

VERSION W8	
Available for group:	
20	

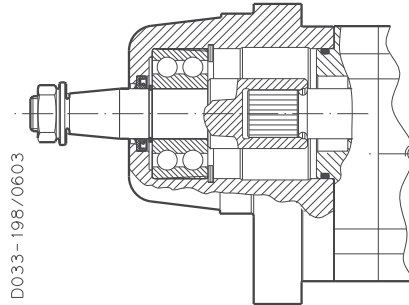

VERSION 4	
Available for group:	
20	

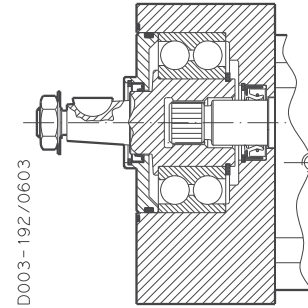

VERSION 5	
Available for group:	
20	

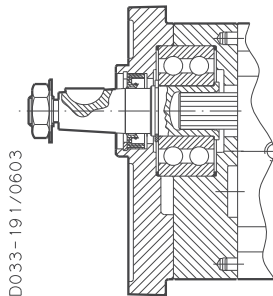

VERSION 6	
Available for group:	
20	

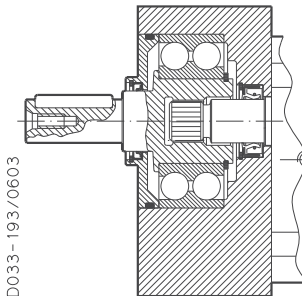

VERSION 7	
Available for group:	
20	

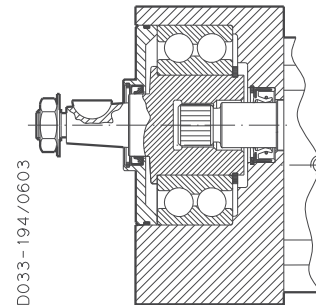

VERSION 8	
Available for group:	
20	

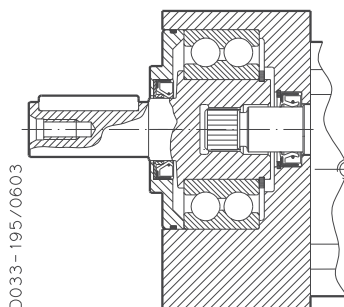

VERSION 9	
Available for group:	
20	

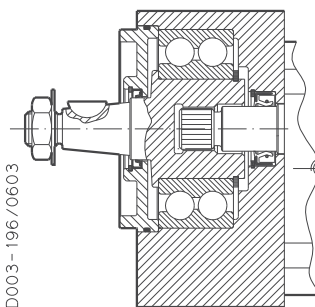

01/10.03

For the outboard bearing life expectancy, diagrams providing approximate selection data will be found on subsequent pages. For particular applications please consult our technical sales department.

D033-197/0603

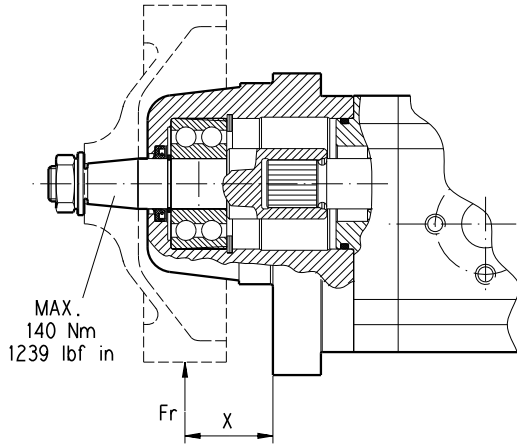

X = Distance of the radial load result from the mounting flange [mm (in)].

Each curve has been obtained at:

Lubricant oil ISO VG 46

Temperature 60 °C (140 °F)

Without or with very low axial load

Example

Fr Radial load	1915 N (430.88 lbf)
X	20 mm (0.7874 in)
Speed	2000 min ⁻¹
Rating fatigue life	≈ 2000 h

Replaces: 01/10.03

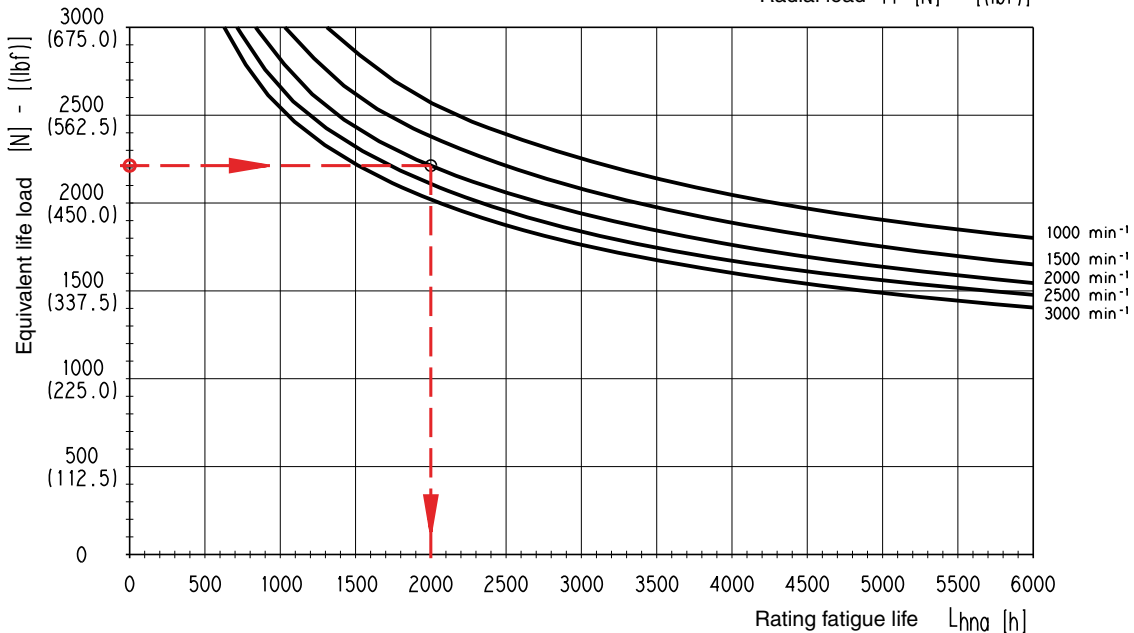
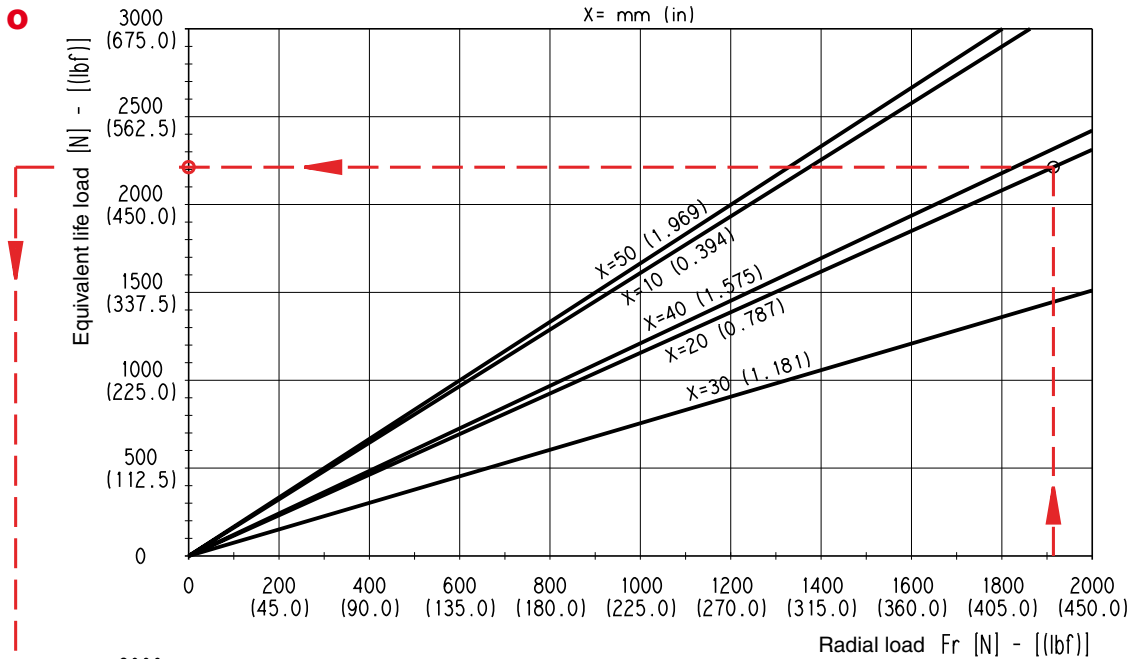

D033-124/0606

02/07.2006

POLARIS 20

VERSION WITH OUTBOARD BEARINGS

4 - 6

Replaces: 01/10.03

D003-114/0603

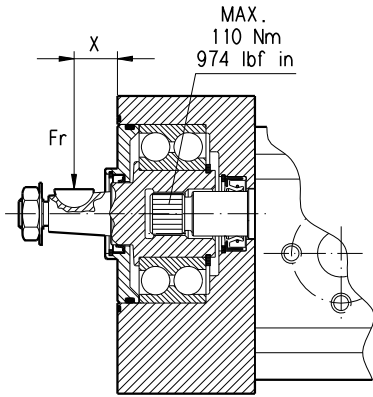

X = Distance of the radial load result from the mounting flange [mm (in)].

Each curve has been obtained at:
Lubricant oil ISO VG 46
Temperature 60 °C (140 °F)
Without or with very low axial load

Example

Fr Radial load	1850 N (416.25 lbf)
X	20 mm (0.7874 in)
Speed	2000 min ⁻¹
Rating fatigue life	≈ 2000 h

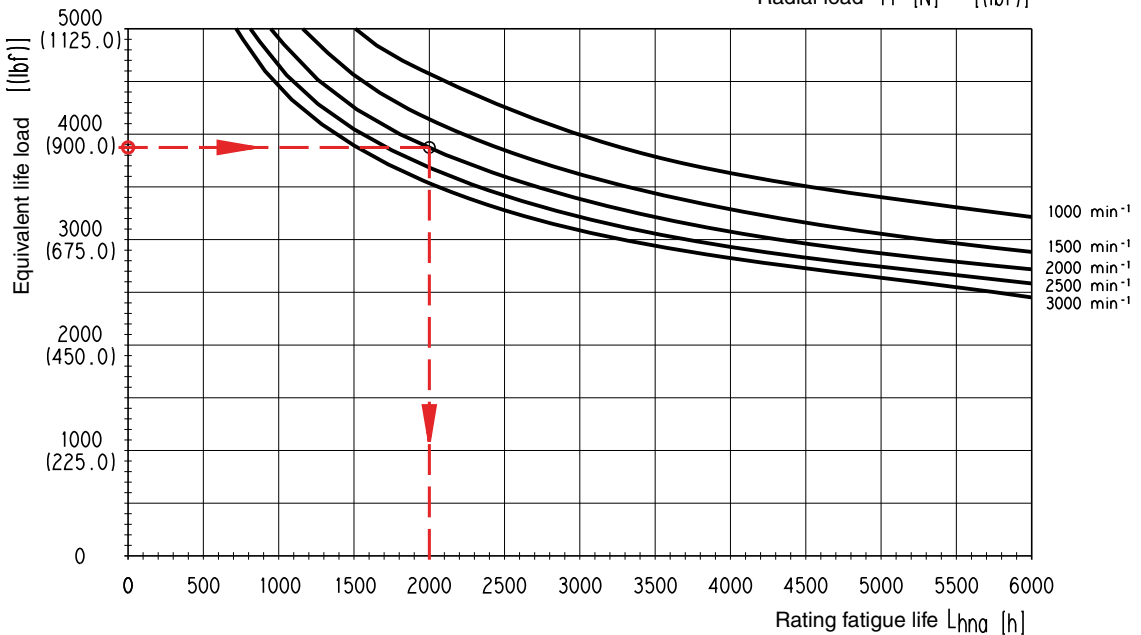
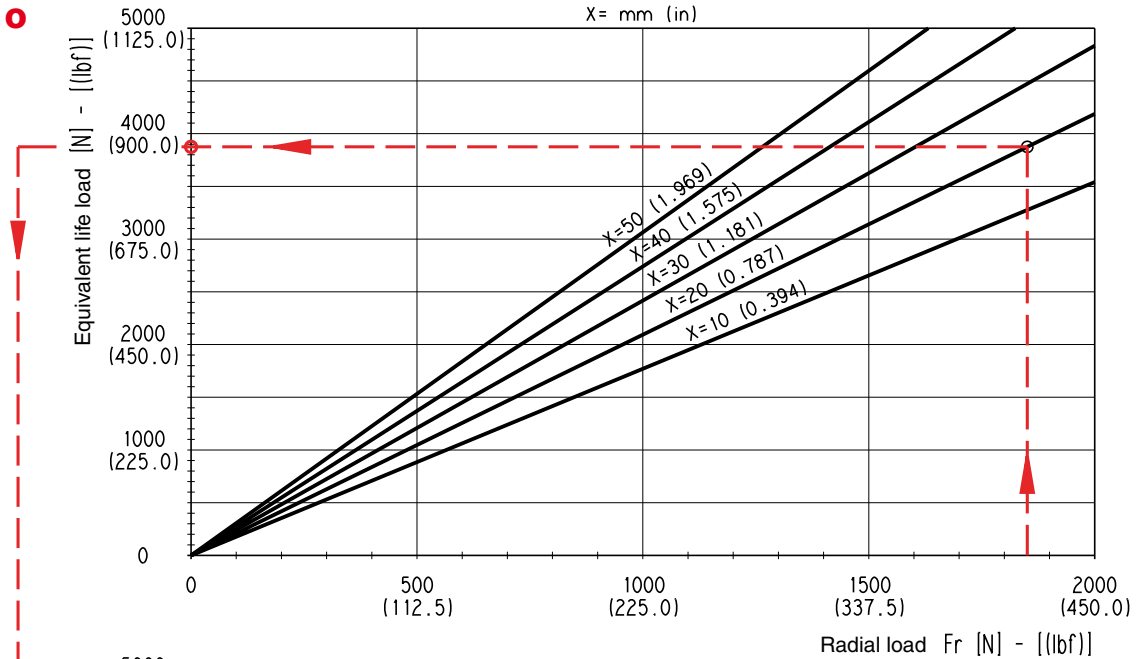

02/07.2006

D033-122/0606

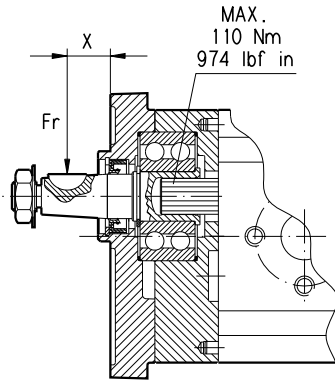

X = Distance of the radial load result from the mounting flange [mm (in)].

Each curve has been obtained at:

Lubricant oil ISO VG 46

Temperature 60 °C (140 °F)

Without or with very low axial load

Example

Fr Radial load	800 N (180 lbf)
X	20 mm (0.7874 in)
Speed	2000 min ⁻¹
Rating fatigue life	≈ 2000 h

D033-115/0603

Replaces: 01/10.03

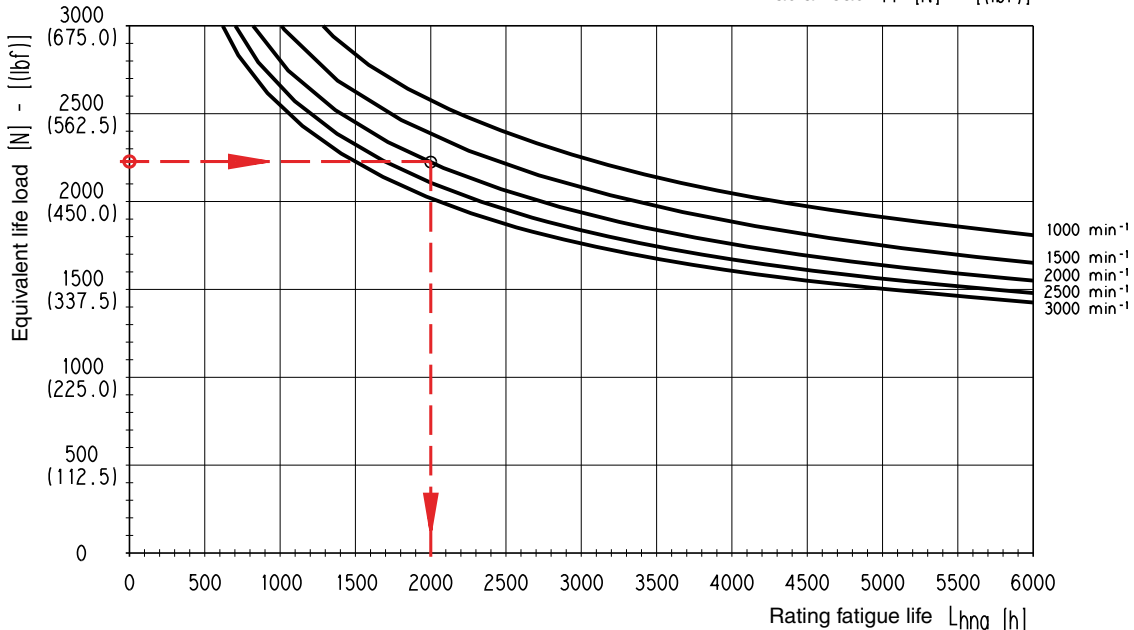
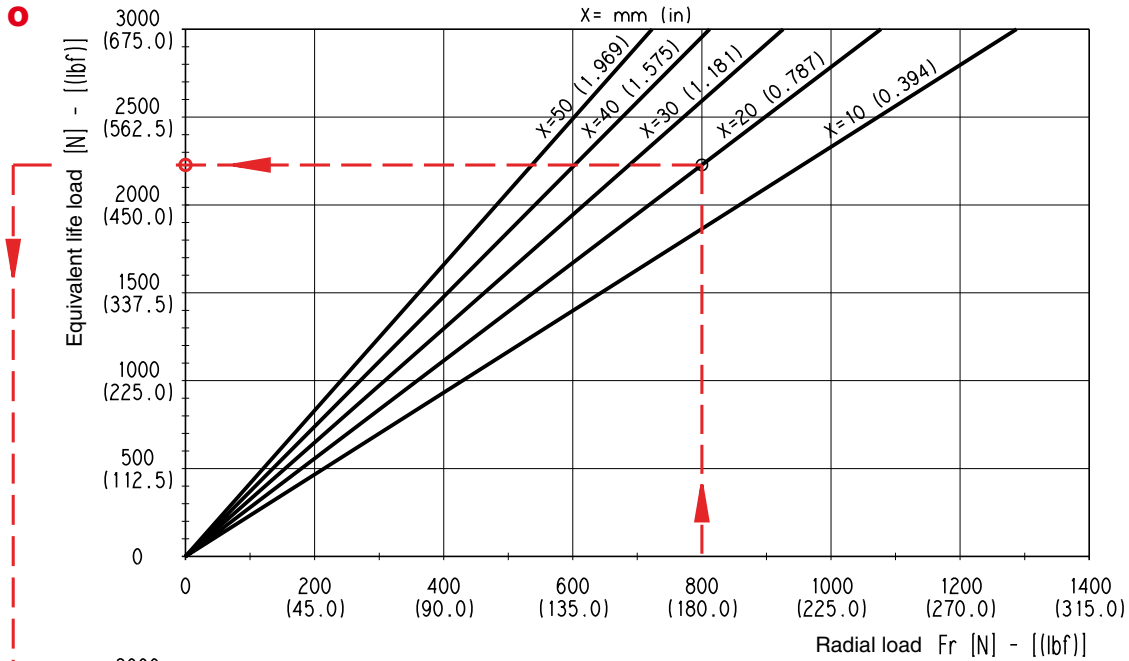

D033-121/0606

02/07.2006

POLARIS 20

VERSION WITH OUTBOARD BEARINGS

7 - 8 - 9

Replaces: 01/10.03

D033-118/0603

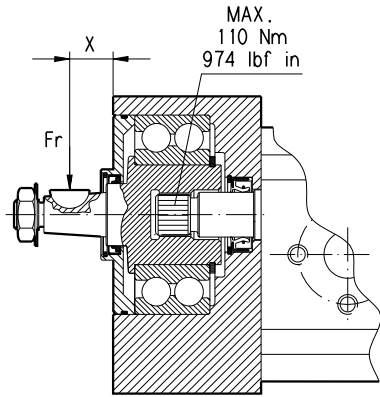

X = Distance of the radial load result from the mounting flange [mm (in)].

Each curve has been obtained at:
Lubricant oil ISO VG 46
Temperature 60 °C (140 °F)
Without or with very low axial load

Example

Fr Radial load	1858 N (418.05 lbf)
X	20 mm (0.7874 in)
Speed	2000 min ⁻¹
Rating fatigue life	≈ 2000 h

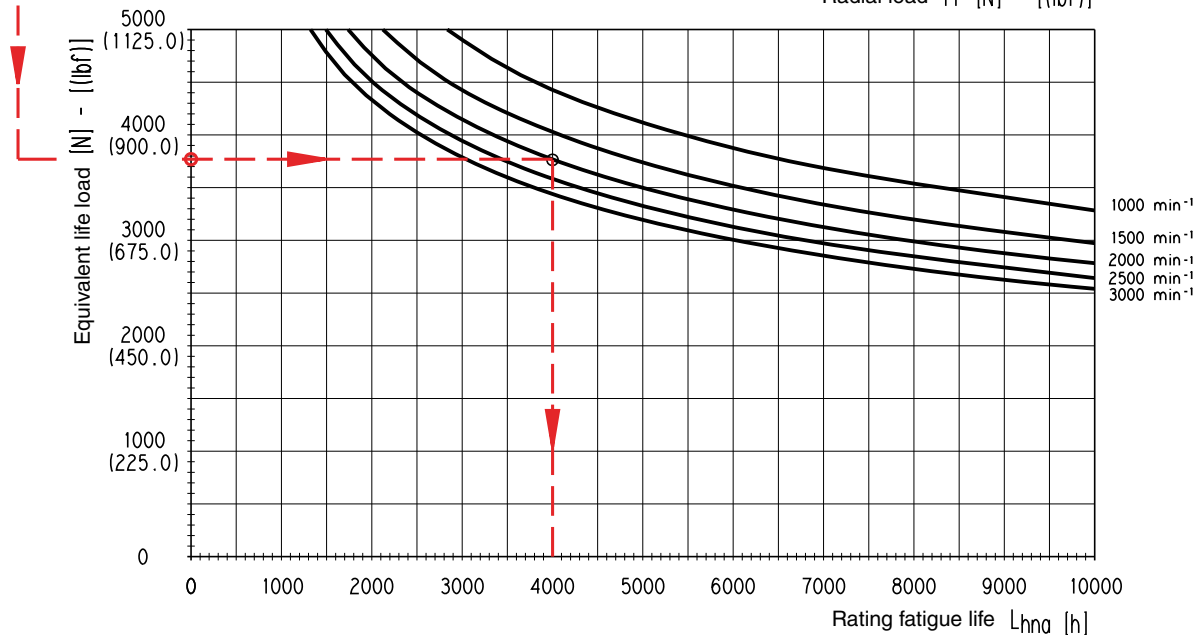
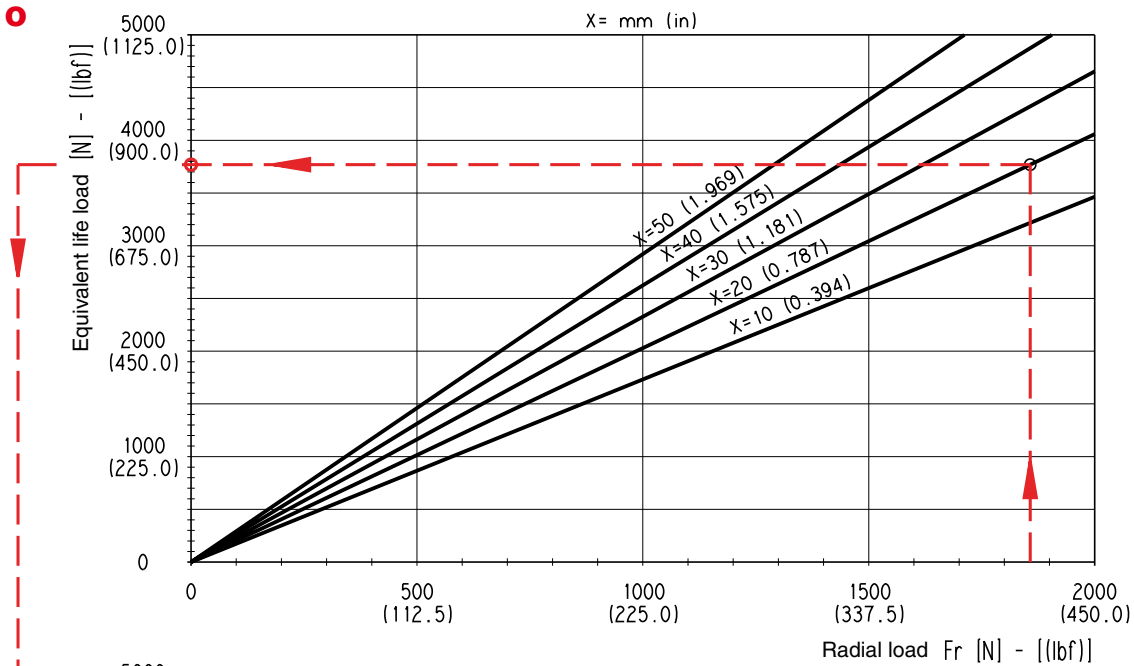

02/07.2006

D033-123/0606

POLARIS 10

DRIVE SHAFTS

EUROPEAN TAPERED 1:8

81

Mounting face refer to flange code **E1**

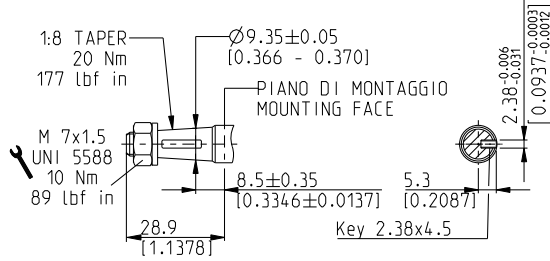

DCAT_033_041

EUROPEAN TAPERED 1:8

86

Mounting face refer to flange code **E7**

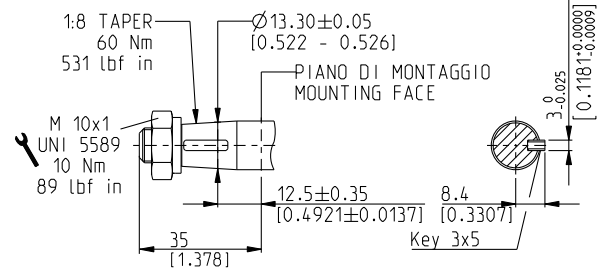

DCAT_033_042

SAE "AA" SPLINE

02

Not available with size:

10•8 With flange: E1, E8, K2, S0

10•1,5 - 10•2,5 - 10•5,8 With flange: R8, R9

Mounting face refer to flange code **R9**

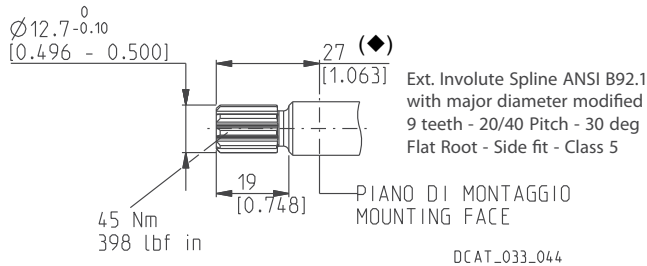

DCAT_033_044

(◆) 24 (0.9449) with flange code **S0**

SAE "AA" STRAIGHT

30

Not available with size:

10•1,5 - 10•2,5 - 10•5,8 With flange: E7, B1, K2, R8, R9

10•2,5 - 10•5,8 With flange: S0

Mounting face refer to flange code **S0**

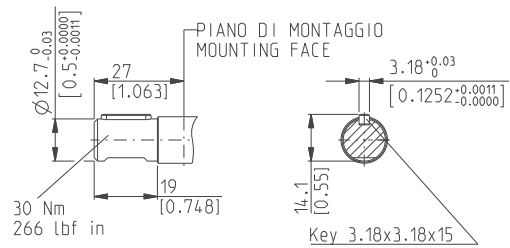

DCAT_033_045

SAE STRAIGHT

36

Not available with size:

10•1,5 10•2,5

Mounting face refer to flange code **R8**

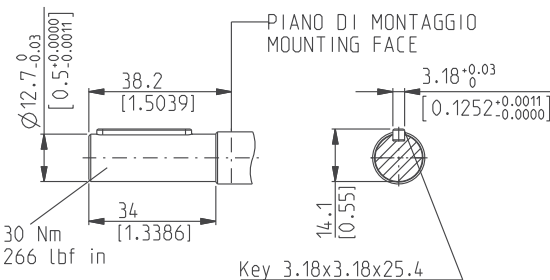

DCAT_033_046

STRAIGHT

29

Not available with size:

10•5,8

Mounting face refer to flange code **E8**

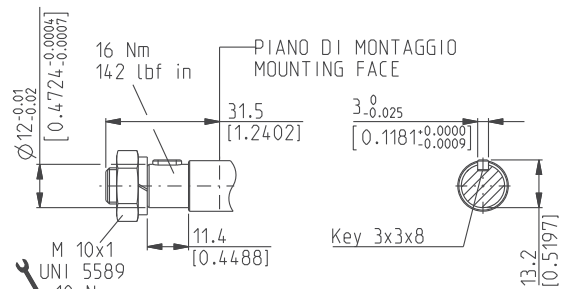

DCAT_033_043

01/10.03

POLARIS 20

DRIVE SHAFTS

EUROPEAN TAPARED 1:8

82

Not available with size:

20•10,5 20•24,5 20•27,8

Mounting face refer to flange code **E2**

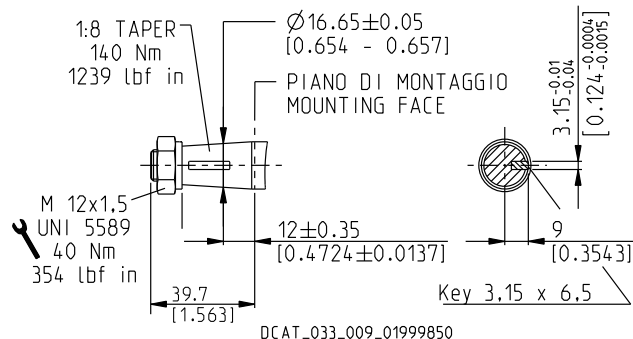

GERMAN TAPERED 1:5

54

Not available with size:

20•7,2 20•10,5 20•19 20•24,5 20•27,8 20•31,5

Mounting face refer to flange code **B2**

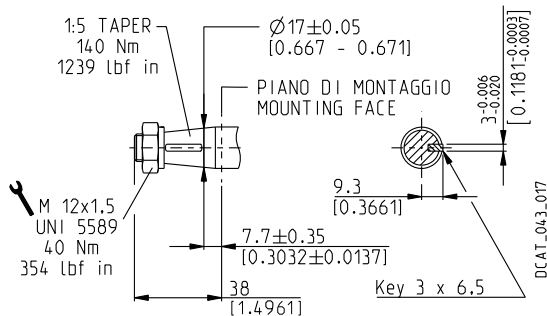

GERMAN TAPARED 1:5

55

Only for version **5, 9** and **W8** with outboard bearing

Mounting face refer to flange code **B2**

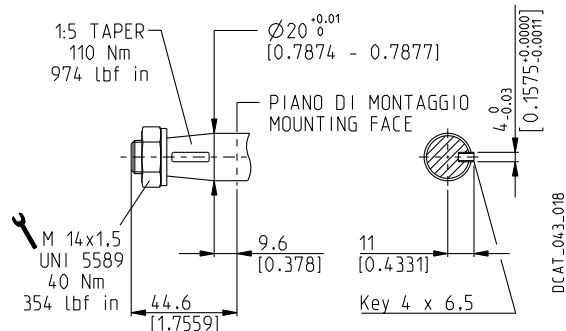

STRAIGHT

46

Not available with size:

20•7,2 20•10,5 20•19 20•24,5 20•25 20•27,8 20•31,5

Mounting face refer to flange code **E2**

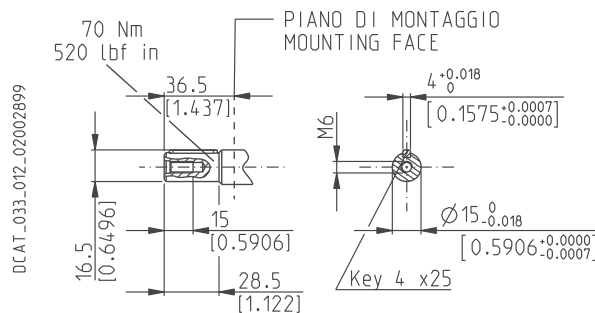

SAE "A" SPLINE

03

Not available with size:

20•24,5 20•27,8

Mounting face refer to flange code **S1**

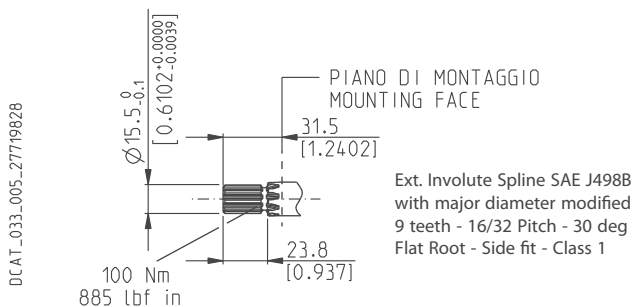

SPLINE

01

Not available with size:

20•6,3 20•9 20•10,5 20•19

Mounting face refer to flange code **S1**

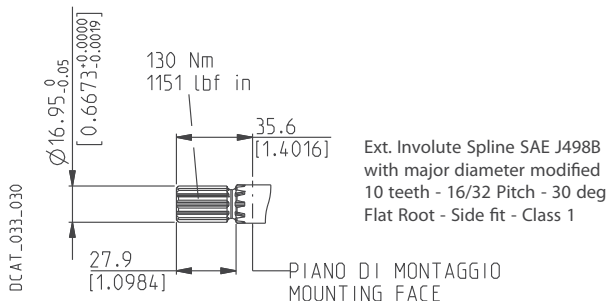

01/10.03

POLARIS 20

DRIVE SHAFTS

SAE SPLINE

07

Not available with size:

20•7,2 20•10,5 20•19 20•24,5 20•27,8

Mounting face refer to flange code **S1**

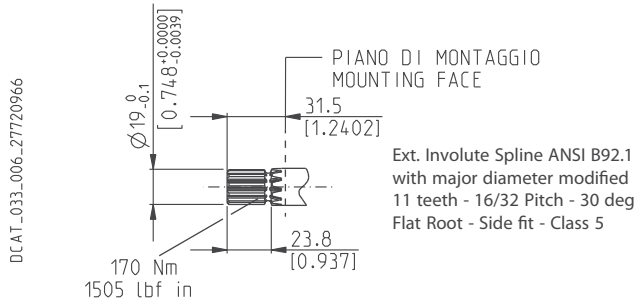

SAE "A" STRAIGHT

31

Not available with size:

20•10,5 20•19 20•24,5 20•27,8

Mounting face refer to flange code **S1**

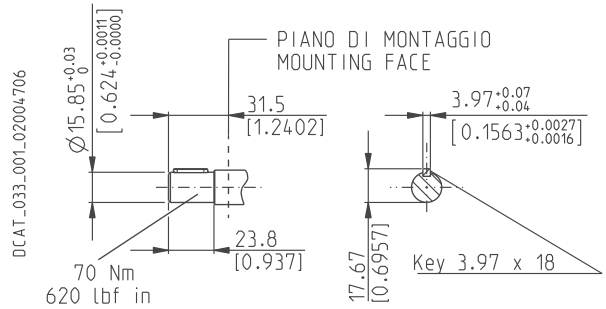

STRAIGHT

49

Not available with size:

20•7,2 20•19 20•24,5

Mounting face refer to flange code **S1**

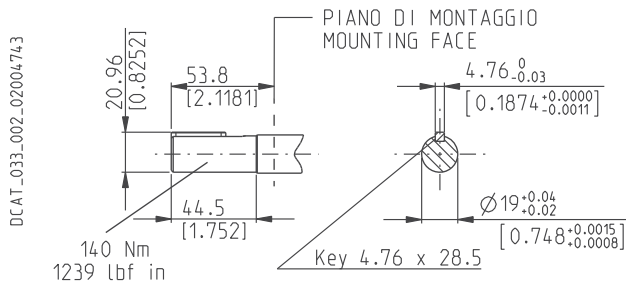

STRAIGHT

50

Not available with size:

20•7,2 20•10,5 20•19 20•24,5 20•27,8

Mounting face refer to flange code **S1**

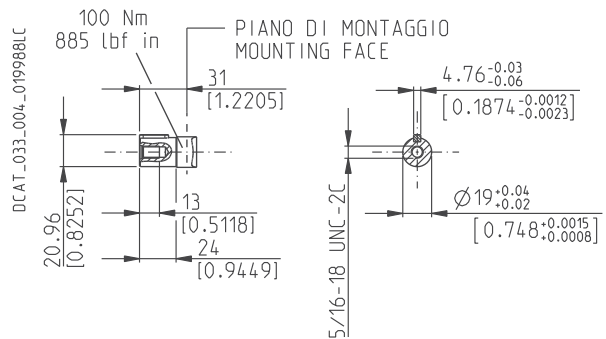

SAE "B" SPLINE

04

Not available with size:

20•4 20•7,2 20•10,5 20•24,5 20•27,8

Mounting face refer to flange code **S5**

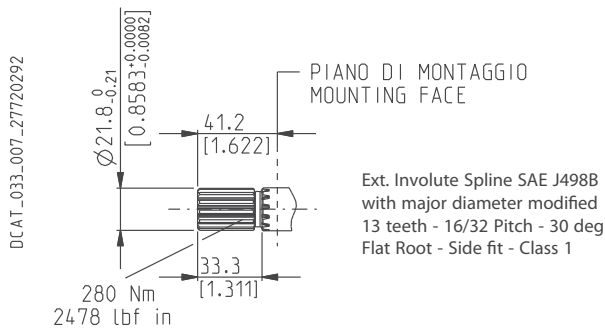

SAE "B" STRAIGHT

32

Not available with size:

20•4 20•7,2 20•8 20•10,5 20•11,2 20•19 20•24,5 20•27,8

Mounting face refer to flange code **S5**

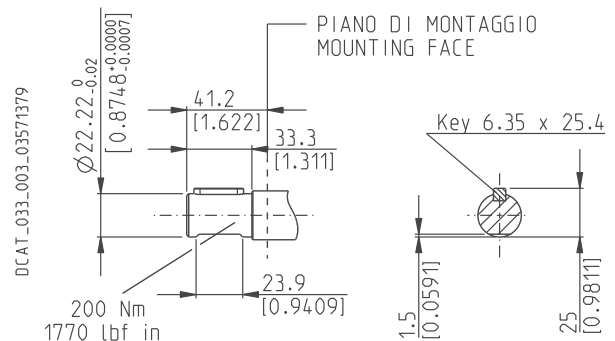

01/10.03

POLARIS 20

DRIVE SHAFTS

DIN 5482 SPLINE **12**

Not available with size:

20•10,5 20•19 20•24,5 20•27,8

Mounting face refer to flange code **B2**

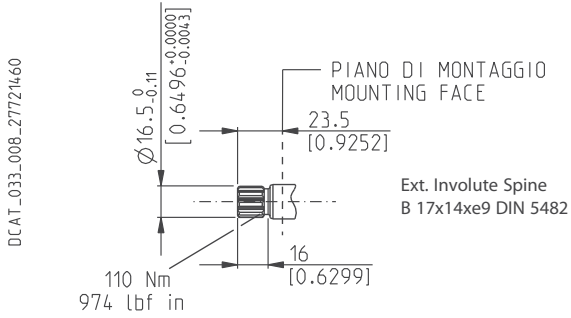

STRAIGHT **B1**

Only for version **8** and **5** with outboard bearing

Mounting face refer to flange code **E2**

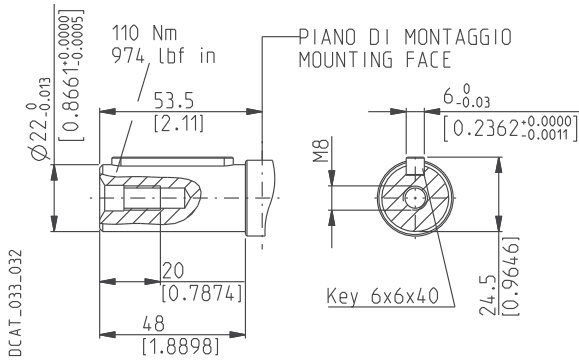

STRAIGHT **48**

Only for version **6** with outboard bearing

Available in 0 version only with size:

20•20

Mounting face refer to flange code **E2**

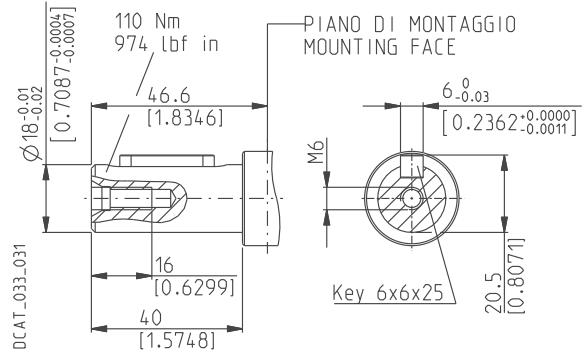

TANG **95**

Not available with size:

20•7,2 20•10,5 20•19 20•24,5 20•27,8

Mounting face refer to flange code **B6**

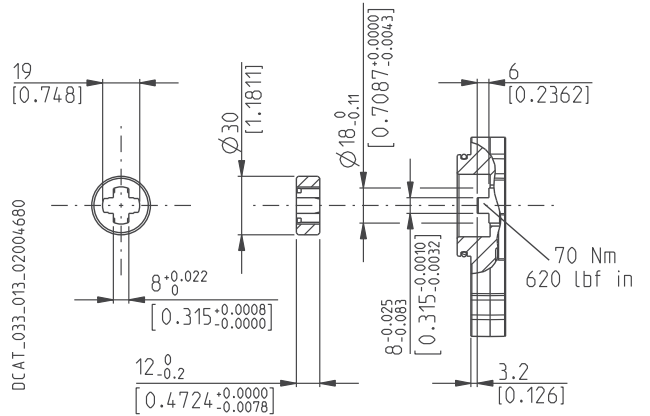

01/10.03

POLARIS 30

DRIVE SHAFTS

EUROPEAN TAPERED 1:8

83

Not available with size:

30•82 30•90

Mounting face refer to flange code **E3**

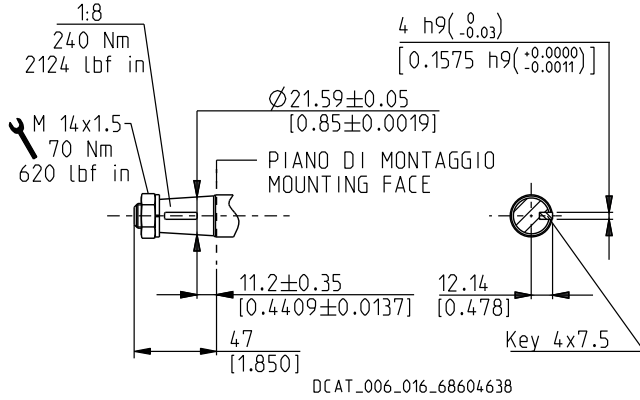

GERMAN TAPERED 1:5

56

Not available with size:

30•61 30•73 30•82 30•90

Mounting face refer to flange code **B3**

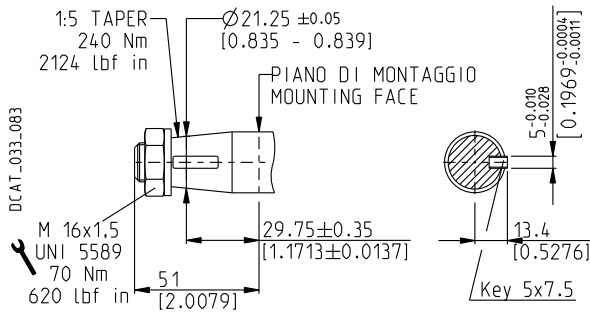

SAE "B" SPLINE

A8

Not available with size:

30•82 30•90

Mounting face refer to flange code **U3**

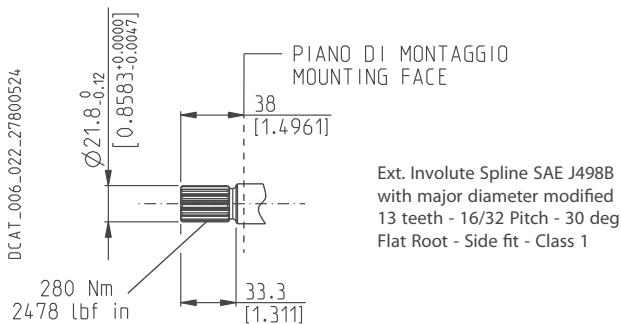

EUROPEAN TAPERED 1:8

84

Not available with size:

30•22 30•27 30•34 30•38

Mounting face refer to flange code **E4**

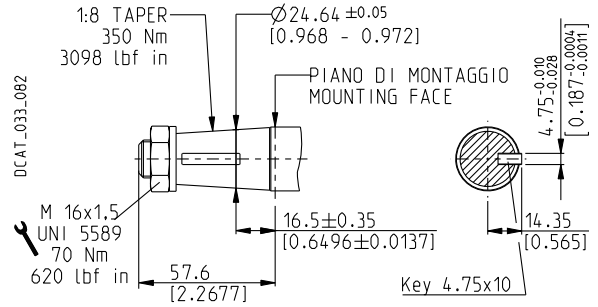

STRAIGHT

41

Not available with size:

30•82 30•90

Mounting face refer to flange code **E3**

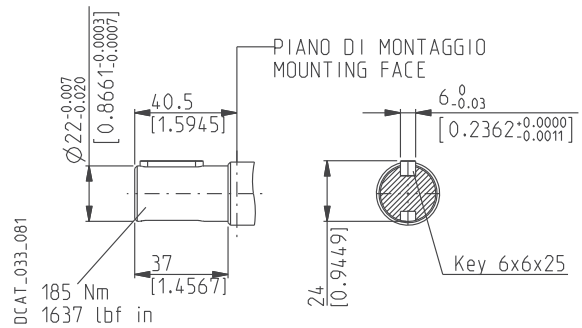

SAE "BB" SPLINE

A5

Not available with size:

30•22 30•38 30•82 30•90

Mounting face refer to flange code **U3**

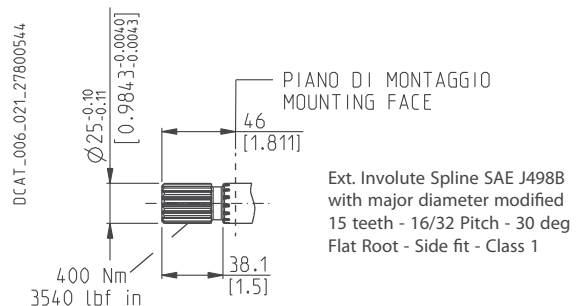

01/10.03

POLARIS 30

DRIVE SHAFTS

SAE "B" SPLINE

04

Mounting face refer to flange code **S5**

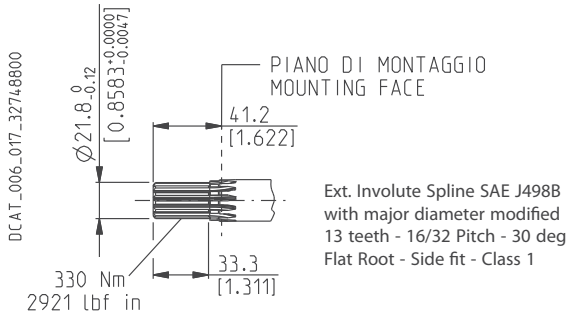

SAE "BB" SPLINE

05

Not available with size:

30•90

Mounting face refer to flange code **S5**

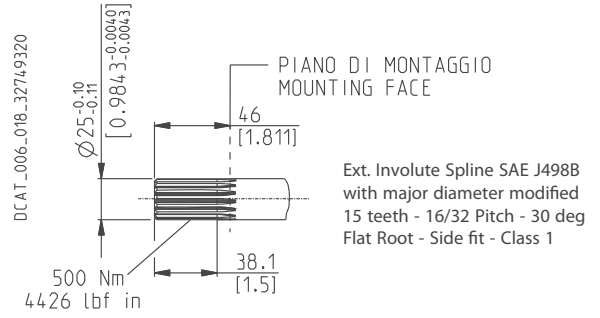

SAE "B" STRAIGHT

32

Mounting face refer to flange code **S5**

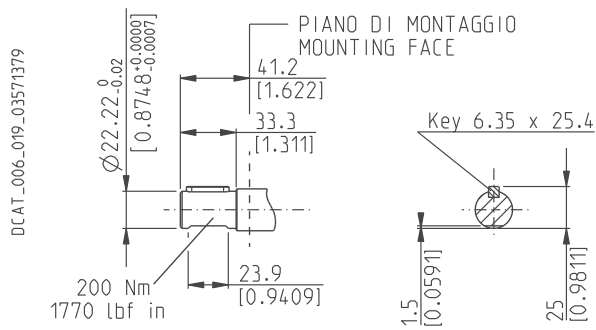

SAE "B" STRAIGHT

33

Mounting face refer to flange code **S5**

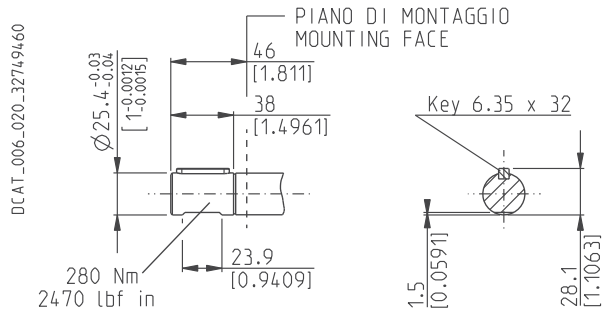

01/10.03

POLARIS 10 MOUNTING FLANGES AND TABLE OF COMPATIBILITY

EUROPEAN

E1

Material: cast iron and aluminium

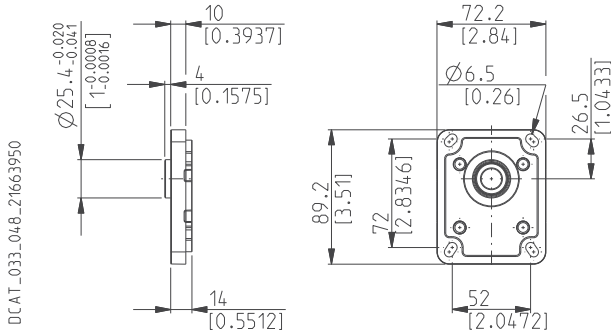

DRIVE SHAFTS
See page 52

VERSIONS
See page 47

81 02 29 86

0 # X X X

Standard combination
X Available combination

EUROPEAN

E7

Material: cast iron and aluminium

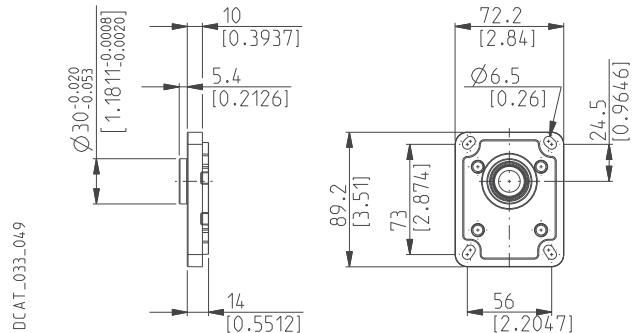

DRIVE SHAFTS
See page 52

VERSIONS
See page 47

86 29 30

0 # X X

Standard combination
X Available combination

Replaces: 01/10.03

EUROPEAN

E8

Material: cast iron and aluminium

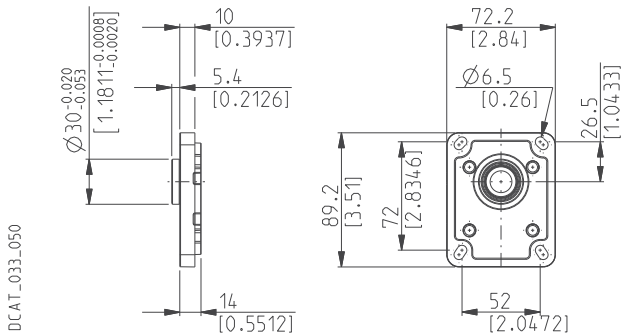

DRIVE SHAFTS
See page 52

VERSIONS
See page 47

29 02

0 # X

Standard combination
X Available combination

GERMAN 2 BOLTS

B1

Material: aluminium

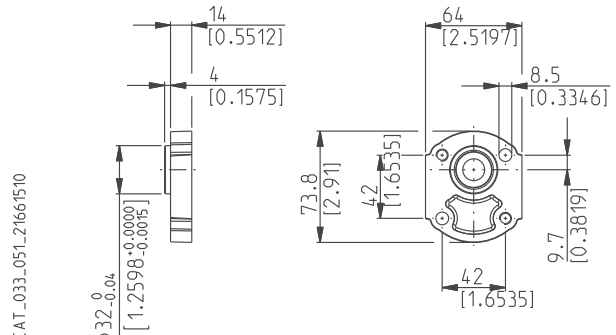

DRIVE SHAFTS
See page 52

VERSIONS
See page 47

30 86

0 # X

Standard combination
X Available combination

02/07.2006

POLARIS 10

MOUNTING FLANGES AND TABLE OF COMPATIBILITY

GERMAN 4 BOLTS

K2

Material: aluminium



Replaces: 01/10.03

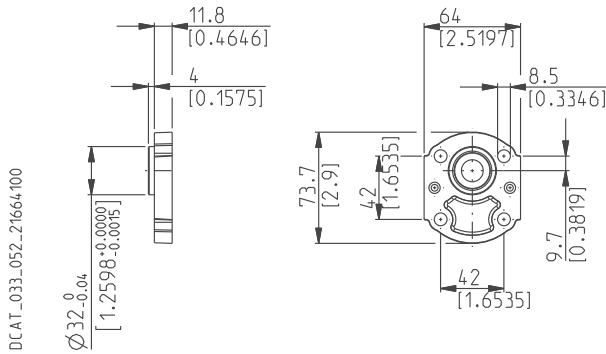

DRIVE SHAFTS
See page 52

VERSIONS
See page 47

02

30

0

X

X

Standard combination
X Available combination

SAE "A-A" 2 BOLTS

S0

Material: cast iron and aluminium

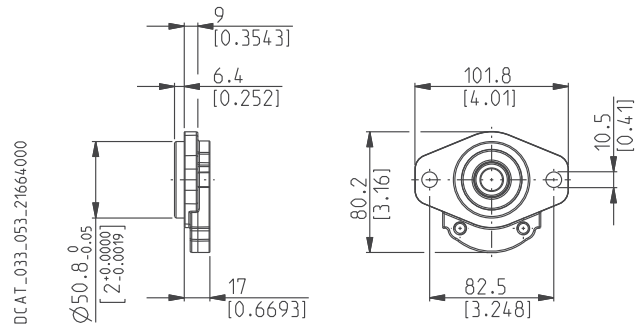

DRIVE SHAFTS
See page 52

VERSIONS
See page 47

30

02

86

0

#

X

X

Standard combination
X Available combination

SAE "A-A" 2-4 BOLTS

R9

Material: cast iron



02/07.2006

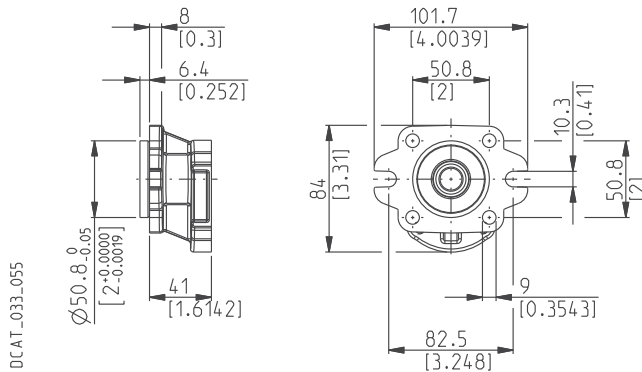

DRIVE SHAFTS
See page 52

VERSIONS
See page 47

02

30

36

0

#

X

#

Standard combination
X Available combination

SAE 2-4 BOLTS

R8

Material: cast iron

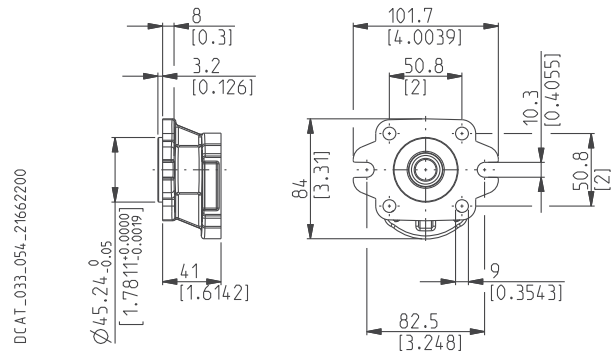

DRIVE SHAFTS
See page 52

VERSIONS
See page 47

02

30

36

0

#

X

#

Standard combination
X Available combination

POLARIS 10 MOUNTING FLANGES AND TABLE OF COMPATIBILITY

SAE 2 BOLTS

W9

Material: cast iron



DCAT_033_057_21662215

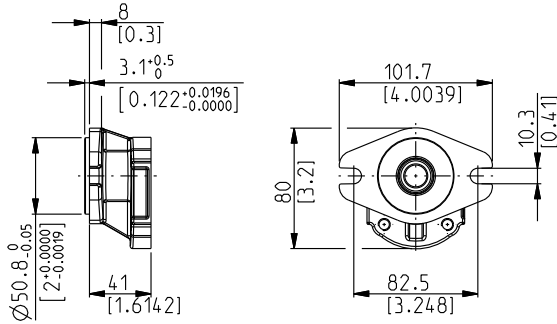

DRIVE SHAFTS
See page 52

VERSIONS
See page 47

36

0

#

- # Standard combination
- X Available combination

Replaces: 01/10.03

02/07.2006

POLARIS 20 MOUNTING FLANGES AND TABLE OF COMPATIBILITY

Replaces: 01/10.03

EUROPEAN

E2

Material: cast iron and aluminium

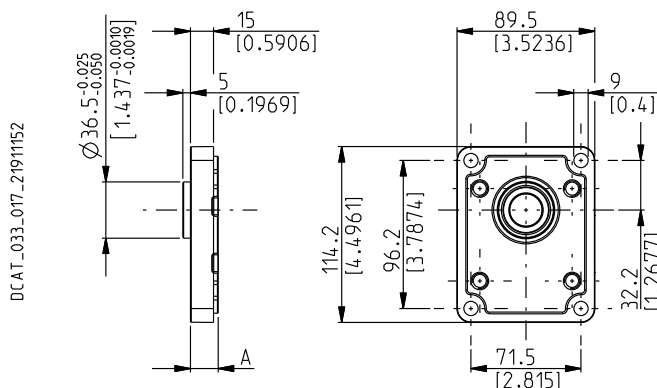

DCAT_033_017_21911152

DRIVE SHAFTS

See page 53 ÷ 55

VERSIONS See page 47	A mm (in)	82	46	B1	03	04	07	12	31	48	49	50	54
0	18 (0.7087)	#	#		X	X	X	X	X	X	X	X	X
4	55,4 (2.1811)	#											
5	43,6 (1.7165)	#		X	X						X	X	X
6	55,4 (2.1811)									#			
7	59,4 (2.3386)	#											
8	59,4 (2.3386)			#									

Standard combination

X Available combination

GERMAN

B2

Material: cast iron and aluminium

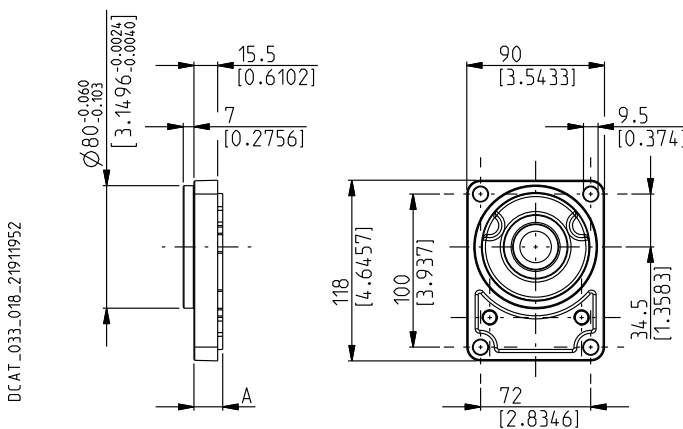

DCAT_033_018_21911952

DRIVE SHAFTS

See page 53 ÷ 55

VERSIONS See page 47	A mm (in)	12	54	55	01	03	31	46	49	82
0	18,8 (0.7402)	#	#		X	X	X	X	X	X
5	44,4 (1.7480)		X	X		X			X	X
9	59,4 (1.7441)			X						

Standard combination

X Available combination

02/07.2006

POLARIS 20 MOUNTING FLANGES AND TABLE OF COMPATIBILITY

GERMAN 2 BOLTS B4

Material: cast iron and aluminium **O**

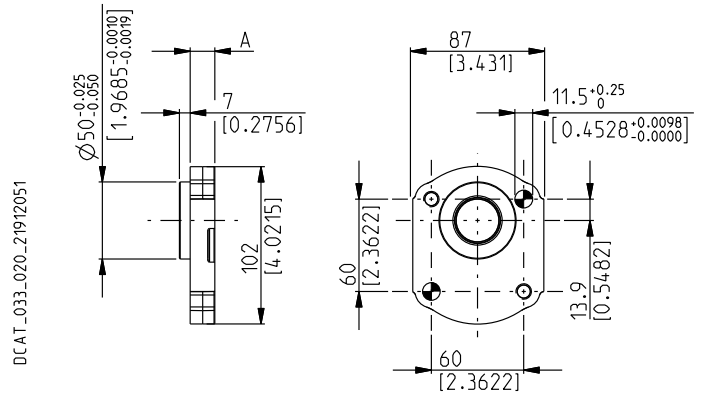

Replaces: 01/10.03

DRIVE SHAFTS
See page 53 ÷ 55

VERSIONS See page 47	A mm (in)	54	03	12	31	49	54	82
0	16 (0.63)	#	X	X	X	X	X	X
5	41,6 (1.6378)	X	X			X	X	X

Standard combination

X Available combination

GERMAN 2 BOLTS B5

Material: cast iron and aluminium **O**

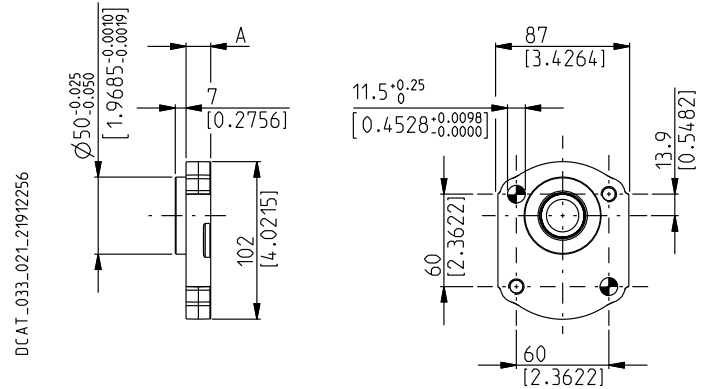

O 02/07.2006

DRIVE SHAFTS
See page 53 ÷ 55

VERSIONS See page 47	A mm (in)	54	03	12	31	49	54	82
0	16 (0.63)	#	X	X	X	X	X	X
5	41,6 (1.6378)	X	X			X	X	X

Standard combination

X Available combination

POLARIS 20 MOUNTING FLANGES AND TABLE OF COMPATIBILITY

Replaces: 01/10.03

GERMAN 4 BOLTS

B6

Material: cast iron and aluminium

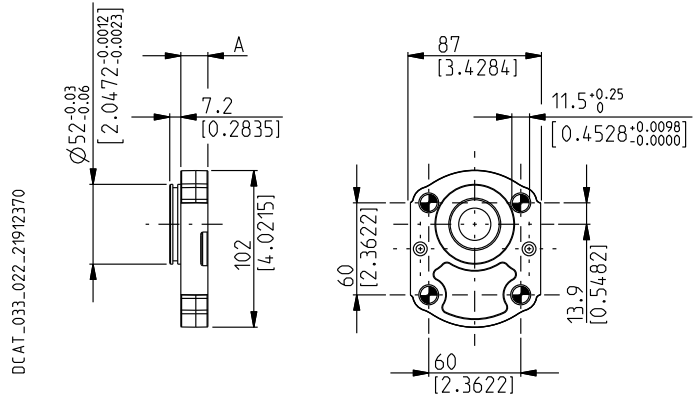

DCAT_033_022_21912370

DRIVE SHAFTS

See page 53 ÷ 55

VERSIONS See page 47	A mm (in)	95	07	12
0	17,7 (0.6968)	#	X	X
5	43,3 (1.747)	X		

Standard combination

X Available combination

SAE "A" 2 BOLTS

S1

Material: cast iron and aluminium

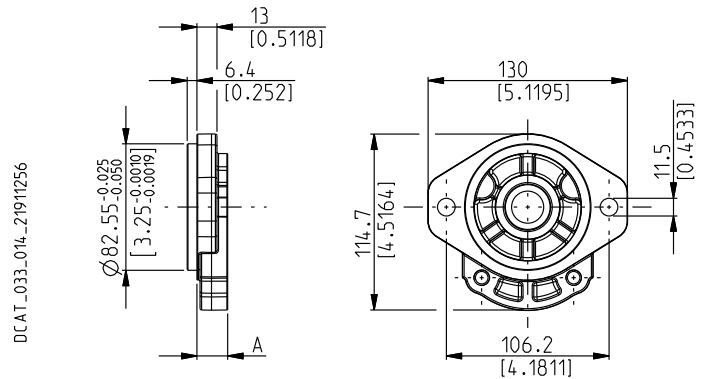

DCAT_033_014_21911256

DRIVE SHAFTS

See page 53 ÷ 55

VERSIONS See page 47	A mm (in)	01	03	04	07	12	31	32	46	49	50	54	82
0	20 (0.787)	#	#	X	#	X	#	X	X	#	X	X	X
5	45,6 (1.7953)		X							X	X	X	X

Standard combination

X Available combination

02/07.2006

POLARIS 20 MOUNTING FLANGES AND TABLE OF COMPATIBILITY

SAE "A" 2 BOLTS S2

Material: cast iron and aluminium ○

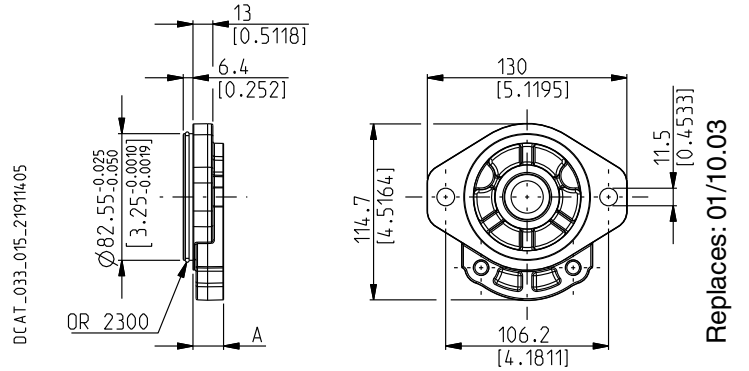

DRIVE SHAFTS
See page 53 ÷ 55

VERSIONS See page 47	A mm (in)	01	03	04	07	12	31	32	46	49	50	54	82
0	20 (0.7874)	#	#	X	#	X	#	X	X	#	X	X	X
5	45,6 (1.7953)		X							X	X	X	X

Standard combination

X Available combination

SAE "A" 2 BOLTS S9

Material: cast iron and aluminium ○

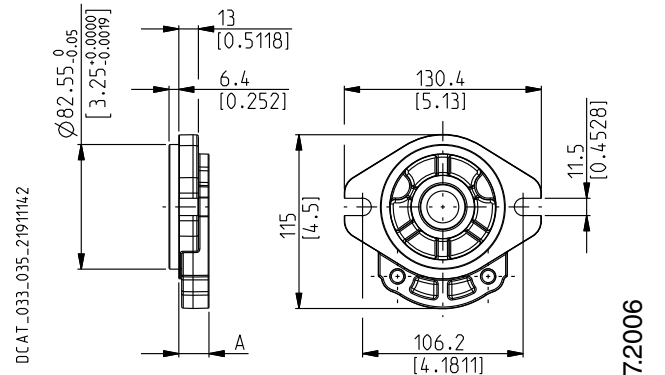

DRIVE SHAFTS
See page 53 ÷ 55

VERSIONS See page 47	A mm (in)	01	03	04	07	12	31	32	46	49	50	54	82
0	20 (0.7874)	#	#	X	#	X	#	X	X	#	X	X	X
5	45,6 (1.7953)		X							X	X	X	X

Standard combination

X Available combination

POLARIS 20

MOUNTING FLANGES AND TABLE OF COMPATIBILITY

Replaces: 01/10.03

SAE "B" 2 BOLTS

S5

Material: cast iron

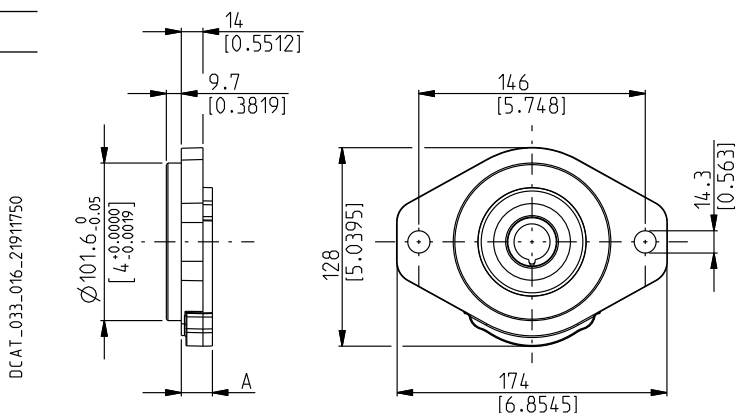

DRIVE SHAFTS

See page 53 ÷ 55

VERSIONS See page 47	A mm (in)	04	32	49
0	20 (0.7874)	#	#	X
5	45,6 (1.7953)			X

Standard combination

X Available combination

GERMAN

W8

Material: cast iron

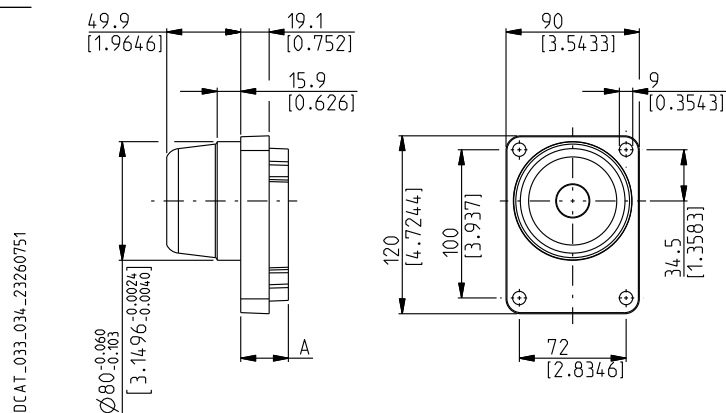

DRIVE SHAFTS

See page 53 ÷ 55

VERSIONS See page 47	A mm (in)	55
W8	32,1 (1.2638)	#

Standard combination

X Available combination

02/07.2006

POLARIS 30 MOUNTING FLANGES AND TABLE OF COMPATIBILITY

EUROPEAN

E3

Material: cast iron



D033-199/0706

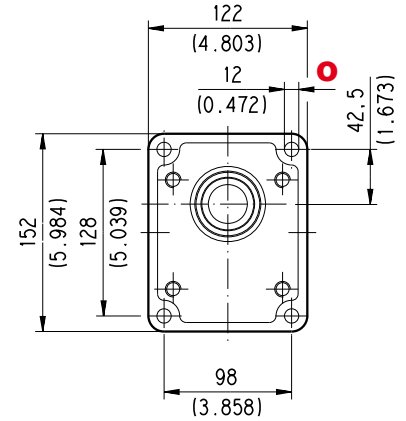
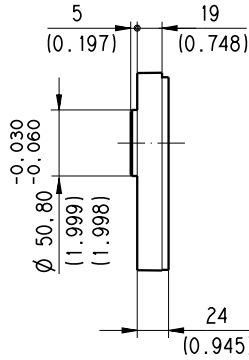

Replaces: 01/10.03

DRIVE SHAFTS

See page 56 and 57

VERSIONS See page 47	83	41	04	05	32	33	A5	A8
0	#	#	X	X	X	X	X	X

Standard combination

X Available combination

EUROPEAN

E4

Material: cast iron



D033-200/0703

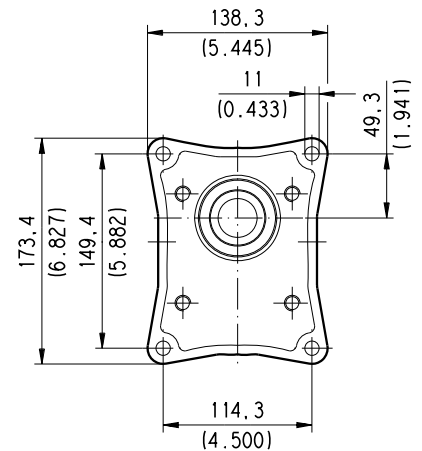
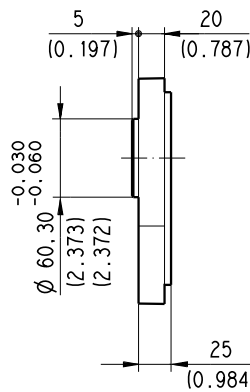

02/07.2006

DRIVE SHAFTS

See page 56 and 57

VERSIONS See page 47	84	41	A5	A8
0	#	X	X	X

Standard combination

X Available combination

POLARIS 30 MOUNTING FLANGES AND TABLE OF COMPATIBILITY

Replaces: 01/10.03

GERMAN

B3

Material: cast iron ○

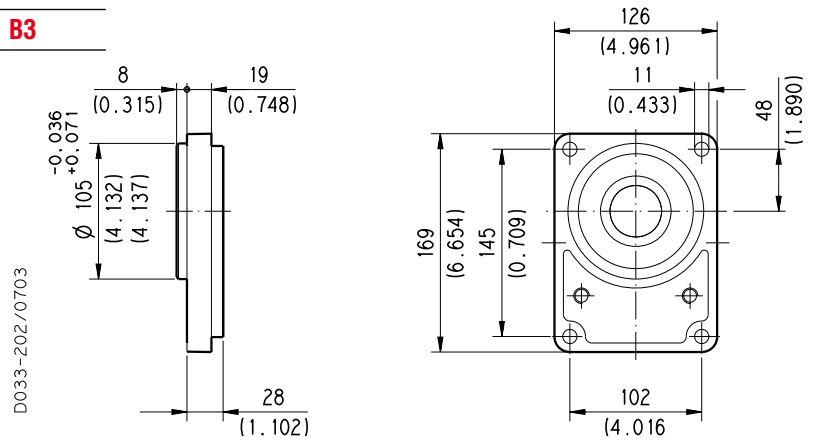

DRIVE SHAFTS
See page 56 and 57

VERSIONS See page 47	56	83	A5	A8
0	#	X	X	X

Standard combination

X Available combination

SAE "B" 2 BOLTS

S5

Material: cast iron ○

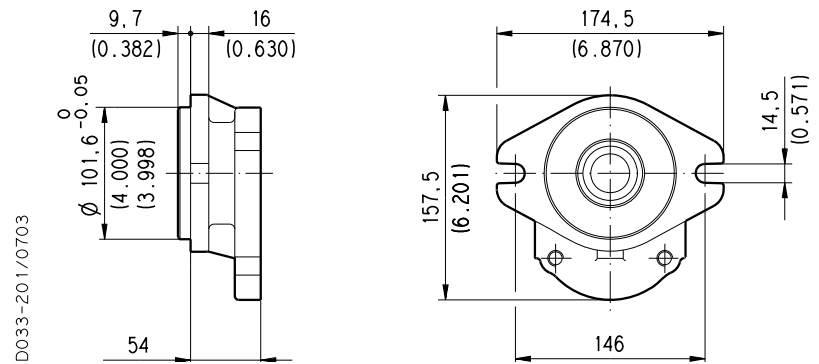

DRIVE SHAFTS
See page 56 and 57

VERSIONS See page 47	04	05	32	33
0	#	#	#	#

Standard combination

X Available combination

○ 02/07.2006

POLARIS 30 MOUNTING FLANGES AND TABLE OF COMPATIBILITY

SAE "B" 2 BOLTS

U3

Material: cast iron ○

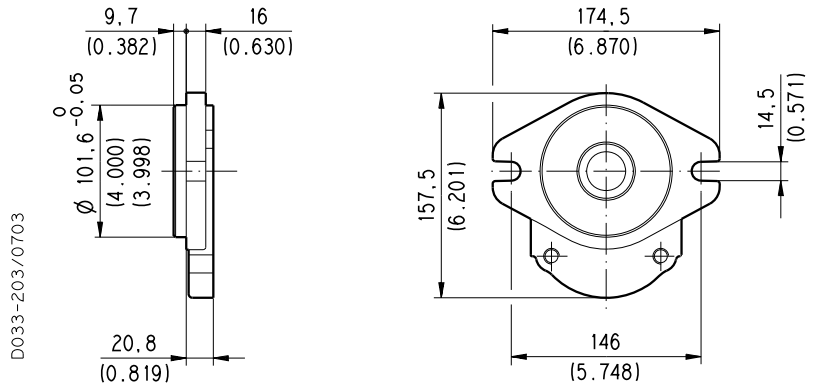

DRIVE SHAFTS
See page 56 and 57

VERSIONS See page 47	A5	A8	83
0	#	#	x

Standard combination
x Available combination

○ 02/07.2006

IN/OUT PORTS TYPE

PORTS TYPE	SIDE PORTS												REAR PORTS					
	German		European		Split SSM		Spit SSS		Gas BSPP		SAE ODT		Gas BSPP		SAE ODT			
	IN	OUT	IN	OUT	IN	OUT	IN	OUT	IN	OUT	IN	OUT	IN	OUT	IN	OUT		
Pump type	IN	OUT	IN	OUT	IN	OUT	IN	OUT	IN	OUT	IN	OUT	IN	OUT	IN	OUT	IN	OUT
Motor type	OUT	IN	OUT	IN	OUT	IN	OUT	IN	OUT	IN	OUT	IN	OUT	IN	OUT	IN	OUT	IN
PL. 10•1	BB	BA							GC	GC	OB	OA	GC	GC	OB	OA		
PL. 10•1,5	BB	BA							GC	GC	OB	OA	GC	GC	OB	OA		
PL. 10•2	BB	BA							GC	GC	OB	OA	GC	GC	OB	OA		
PL. 10•2,5	BB	BA							GC	GC	OB	OA	GC	GC	OB	OA		
PL. 10•3,15	BB	BA							GC	GC	OB	OA	GC	GC	OB	OA		
PL. 10•4	BB	BA							GC	GC	OB	OA	GC	GC	OB	OA		
PL. 10•5	BB	BA							GD	GD	OB	OA	GD	GD	OB	OA		
PL. 10•5,8	BB	BA							GD	GD	OB	OA	GD	GD	OB	OA		
PL. 10•6,3	BB	BA							GD	GD	OB	OA	GD	GD	OB	OA		
PL. 10•8	BB	BA							GD	GD	OC	OB	GD	GD	OB	OB		
PL. 10•10	BB	BA							GD	GD	OC	OB	GD	GD	OB	OB		
PL. 20•4	BE	BC	EA	EA	MA	MA	SA	SA	GD	GD	OC	OC	GD	GD	OC	OC		
PL. 20•6,3	BE	BC	EA	EA	MA	MA	SA	SA	GD	GD	OC	OC	GD	GD	OC	OC		
PL. 20•7,2	BE	BC	EA	EA	MA	MA	SA	SA	GD	GD	OC	OC	GD	GD	OC	OC		
PL. 20•8	BE	BC	EA	EA	MA	MA	SA	SA	GD	GD	OC	OC	GD	GD	OC	OC		
PL. 20•9	BE	BC	EA	EA	MA	MA	SA	SA	GD	GD	OC	OC	GD	GD	OC	OC		
PL. 20•10,5	BE	BC	EA	EA	MA	MA	SA	SA	GD	GD	OC	OC	GD	GD	OC	OC		
PL. 20•11,2	BE	BC	EA	EA	MA	MA	SA	SA	GD	GD	OC	OC	GD	GD	OC	OC		
PL. 20•14	BE	BC	EB	EA	MB	MA	SB	SA	GE	GD	OD	OC	GE	GD	OD	OC		
PL. 20•16	BE	BC	EB	EA	MB	MA	SB	SA	GE	GD	OD	OC	GE	GD	OD	OC		
PL. 20•19	BE	BC	EB	EA	MB	MA	SB	SA	GE	GD	OD	OC	GE	GD	OD	OC		
PL. 20•20	BE	BC	EB	EA	MB	MA	SB	SA	GE	GD	OD	OC	GE	GD	OD	OC		
PL. 20•24,5	BE	BC	EB	EA	MC	MB	SC	SB	GE	GD	OD	OC	GE	GD	OD	OC		
PL. 20•25	BE	BC	EB	EA	MC	MB	SC	SB	GE	GD	OD	OC	GE	GD	OD	OC		
PL. 20•27,8	BE	BC	EB	EA	MC	MB	SC	SB	GE	GD	OD	OC	GE	GD	OD	OC		
PL. 20•31,5	BE	BC	EB	EA	MC	MB	SC	SB	GE	GD	OD	OC	GE	GD	OD	OC		
PL. 30•22	BM	BL	ED	EB	MB	MA	SB	SA	GF	GF	OF	OD						
PL. 30•27	BM	BL	ED	EB	MC	MB	SC	SB	GF	GF	OF	OD						
PL. 30•34	BM	BL	ED	EB	MC	MB	SC	SB	GF	GF	OF	OD						
PL. 30•38	BM	BL	ED	EB	MD	MC	SD	SC	GF	GF	OG	OF						
PL. 30•43	BM	BL	ED	EB	MD	MC	SD	SC	GF	GF	OG	OF						
PL. 30•46	BM	BL	ED	EB	MD	MC	SD	SC	GF	GF	OG	OF						
PL. 30•51	BM	BL	ED	EB	MD	MC	SD	SC	GF	GF	OG	OF						
PL. 30•61	BM	BL	ED	EB	ME	MD	SE	SD	GG	GF	OH	OG						
PL. 30•73	BM	BL	EF	ED	ME	MD	SE	SD	GG	GF	OH	OG						
PL. 30•82	BM	BL	EF	ED	ME	MD	SE	SD	GH	GG	OH	OG						
PL. 30•90	BM	BL	EF	ED	MF	ME	SF	SE	GH	GG	OH	OG						

01/10.03

EXTERNAL DRAIN PORTS

IN/OUT PORTS TYPE	SIDE PORTS						REAR PORTS	
	German	European	Split SSM	Spit SSS	Gas BSPP	SAE ODT	Gas BSPP	SAE ODT
PL. 10	GA	-	-	-	GA	03	GA	03
PL. 20	TA	GB	GB	03	GB	03	GB	03
PL. 30	GC	GC	GC	OA	GC	OA	-	-

DRAIN PORTS SIZES

 Tightening torque for low pressure side port

GAS STRAIGHT THREAD PORTS

BSPP

British standard pipe parallel (55°) conforms to UNI - ISO 228

CODE	NOMINAL SIZE	A	Ø B	Ø C	D	E	 Nm (lbf in)
			mm (in)	mm (in)	mm (in)	mm (in)	
GA	1/8"	G 1/8	16,5 (0.6496)	8,75 (0.3444)	12 (0.4724)	1 (0.0394)	5 ^{+0,25} (44 ÷ 46)
GB	1/4"	G 1/4	21,5 (0.8465)	12 (0.4724)	15 (0.5906)	1,5 (0.0591)	15 ⁺¹ (133 ÷ 142)

DCAT_006_026_21064779

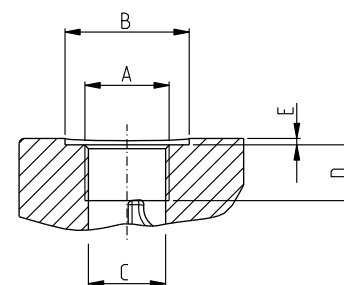

METRIC STRAIGHT THREAD PORTS ISO 6149

METRIC

Metric thread ISO 60° conforms to ISO/R 262

CODE	A	Ø B	Ø C	D	E	 Nm (lbf in)
		mm (in)	mm (in)	mm (in)	mm (in)	
TA	M 10x1	22 (0.8661)	9 (0.3543)	13 (0.5118)	0,5 (0.0197)	10 ^{+0,5} (89 ÷ 93)

DCAT_006_027_21060524

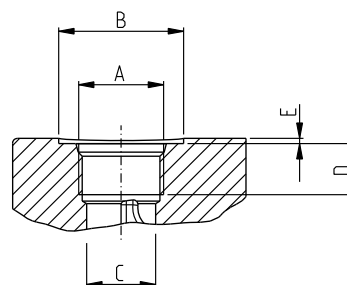

SAE STRAIGHT THREAD PORTS J514

ODT

American straight UNC-UNF 60° conforms to ANSI B 1.1

CODE	A	Ø B	Ø C	D	E	 Nm (lbf in)
		mm (in)	mm (in)	mm (in)	mm (in)	
03	7/16"-20 UNF-2B	21 (0.8267)	9,5 (0.3740)	14 (0.5512)	1 (0.0394)	12 ⁺¹ (106 ÷ 115)

Other drain ports are shown on subsequent pages.

01/10.03

PORTS SIZE

 Tightening torque for low pressure side port



 Tightening torque for high pressure side port [values obtained at 5075 psi (350 bar)]

For reversible rotation, please consult only the tightening torque for high pressure side port

GERMAN FLANGED PORTS - 4 Bolts

GERMAN

Metric thread ISO 60° conforms to ISO/R 262

CODE	A	B	C		
	mm (in)	mm (in)	Thread Depth mm (in)	Nm (lbf in)	Nm (lbf in)
BA	8 (0.3150)	30 (1.1811)	M6 12 (0.4724)	8 ^{+0.5} (71 ÷ 75)	8 ^{+0.5} (71 ÷ 75)
BB	13 (0.5118)	30 (1.1811)	M6 12 (0.4724)	8 ^{+0.5} (71 ÷ 75)	8 ^{+0.5} (71 ÷ 75)
BC	15 (0.5906)	35 (1.3780)	M6 12 (0.4724)	8 ^{+0.5} (71 ÷ 75)	8 ^{+0.5} (71 ÷ 75)
BE	20 (0.7874)	40 (1.5748)	M6 12 (0.4724)	8 ^{+0.5} (71 ÷ 75)	8 ^{+0.5} (71 ÷ 75)
BL	19 (0.7480)	55 (2.1654)	M8 18 (0.7087)	15 ⁺¹ (133 ÷ 142)	20 ⁺¹ (177 ÷ 186)
BM	27 (1.0630)	55 (2.1654)	M8 18 (0.7087)	15 ⁺¹ (133 ÷ 142)	20 ⁺¹ (177 ÷ 186)

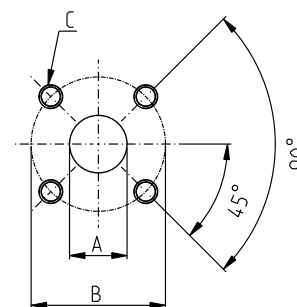

DCAT_033_028_17661888



EUROPEAN FLANGED PORTS - 4 Bolts

EUROPEAN

Metric thread ISO 60° conforms to ISO/R 262

CODE	A	B	C		
	mm (in)	mm (in)	Thread Depth mm (in)	Nm (lbf in)	Nm (lbf in)
EA	13 (0.5118)	30 (1.1811)	M 6 13 (0.5118)	8 ^{+0.5} (71 ÷ 75)	8 ^{+0.5} (71 ÷ 75)
EB	19 (0.7480)	40 (1.5748)	M 8 14 (0.5512)	15 ⁺¹ (133 ÷ 142)	15 ⁺¹ (133 ÷ 142)
			M 8 (◆) 18 (0.7087)	15 ⁺¹ (◆) (133 ÷ 142)	15 ⁺¹ (◆) (133 ÷ 142)
ED	27 (1.0630)	51 (2.0079)	M 10 18 (0.7087)	20 ⁺¹ (177 ÷ 186)	30 ^{+2.5} (266 ÷ 288)
EF	33 (1.2992)	62 (2.4409)	M 12 18 (0.7087)	25 ⁺¹ (221 ÷ 230)	50 ^{+2.5} (443 ÷ 465)

01/10.03

(◆) For POLARIS 30

DCAT_006_024_21060533

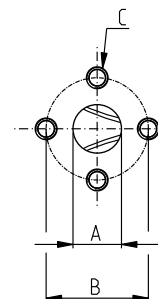

PORTS SIZES

 Tightening torque for low pressure side port



 Tightening torque for high pressure side port [values obtained at 5075 psi (350 bar)]

For reversible rotation, please consult only the tightening torque for high pressure side port

SAE FLANGED PORTS J518 - Standard pressure series 3000 PSI

SSM

Metric thread ISO 60° to ISO/R 262

CODE	A	B	C	D		
	mm (in)	mm (in)	mm (in)	Thread Depth mm (in)	Nm (lbf in)	Nm (lbf in)
MA	12,5 (0.4921)	38,1 (1.50)	17,5 (0.6890)	M 8	15 ⁺¹	15 ⁺¹
				14 (0.5512)	(133 ÷ 142)	(133 ÷ 142)
				M 8 (◆)	20 ⁺¹ (◆)	20 ⁺¹ (◆)
MB	19 (0.7480)	47,6 (1.8740)	22,2 (0.8740)	22 (0.8661)	(177 ÷ 186)	(177 ÷ 186)
				M 10	20 ⁺¹	25 ⁺¹
				14 (0.5512)	(177 ÷ 186)	(266 ÷ 288)
MC	25,4 (1.0000)	52,4 (2.0630)	26,2 (1.0315)	M 10 (◆)	20 ⁺¹ (◆)	35 ^{+2,5} (◆)
				22 (0.8661)	(177 ÷ 186)	(310 ÷ 332)
				M 10	20 ⁺¹	25 ⁺¹
MD	30,5 (1.2008)	58,7 (2.3110)	30,2 (1.1890)	14 (0.5512)	(177 ÷ 186)	(266 ÷ 288)
				M 10 (◆)	20 ⁺¹ (◆)	35 ^{+2,5} (◆)
				22 (0.8661)	(177 ÷ 186)	(310 ÷ 332)
ME	39,3 (1.5472)	69,8 (2.7480)	35,7 (1.4055)	M 12	30 ^{+2,5}	60 ⁺⁵
				22 (0.8661)	(266 ÷ 288)	(531 ÷ 575)
MF	51 (2.0079)	77,8 (3.0630)	42,9 (1.6890)	M 12	30 ^{+2,5}	60 ⁺⁵
				22 (0.8661)	(266 ÷ 288)	(531 ÷ 575)

(◆) For POLARIS 30

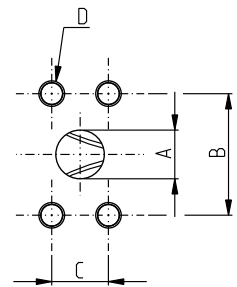

DCAT_006_025_21064252



SAE FLANGED PORTS J518 - Standard pressure series 3000 PSI

SSS

American straight thread UNC-UNF 60° conforms to ANSI B 1.1

CODE	A	B	C	D		
	mm (in)	mm (in)	mm (in)	Thread Depth mm (in)	Nm (lbf in)	Nm (lbf in)
SA	12,5 (0.4921)	38,1 (1.50)	17,5 (0.6890)	5/16-18 UNC-2B	15 ⁺¹	15 ⁺¹
				14 (0.5512)	(133 ÷ 142)	(133 ÷ 142)
				5/16-18 UNC-2B (◆)	20 ⁺¹ (◆)	20 ⁺¹ (◆)
SB	19 (0.7480)	47,6 (1.8740)	22,2 (0.8740)	22 (0.8661)	(177 ÷ 186)	(177 ÷ 186)
				3/8-16 UNC-2B	20 ⁺¹	20 ⁺¹
				14 (0.5512)	(177 ÷ 186)	(177 ÷ 186)
SC	25,4 (1.0000)	52,4 (2.0630)	26,2 (1.0315)	3/8-16 UNC-2B (◆)	30 ^{+2,5} (◆)	20 ⁺¹ (◆)
				22 (0.8661)	(266 ÷ 288)	(177 ÷ 186)
				3/8-16 UNC-2B	20 ⁺¹	25 ⁺¹
SD	30,5 (1.2008)	58,7 (2.3110)	30,2 (1.1890)	14 (0.5512)	(177 ÷ 186)	(221 ÷ 230)
				3/8-16 UNC-2B (◆)	20 ⁺¹ (◆)	30 ^{+2,5} (◆)
				22 (0.8661)	(177 ÷ 186)	(266 ÷ 288)
SE	39,3 (1.5472)	69,8 (2.7480)	35,7 (1.4055)	7/16-14 UNC-2B	20 ⁺¹	45 ^{+2,5}
				22 (0.8661)	(177 ÷ 186)	(398 ÷ 420)
SF	51 (2.0079)	77,8 (3.0630)	42,9 (1.6890)	1/2-13 UNC-2B	30 ^{+2,5}	70 ⁺⁵
				22 (0.8661)	(266 ÷ 288)	(620 ÷ 664)

(◆) For POLARIS 30

DCAT_006_028_21060740

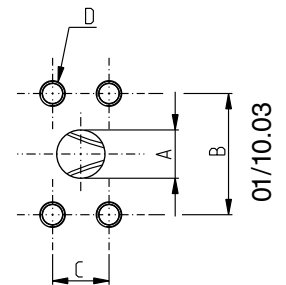

01/10.03

PORTS SIZES



Tightening torque for low pressure side port



Tightening torque for high pressure side port [values obtained at 5075 psi (350 bar)]

For reversible rotation, please consult only the tightening torque for high pressure side port

Replaces: 01/10.03

GAS STRAIGHT THREAD PORTS

BSPP

British standard pipe parallel (55°) conforms to UNI - ISO 228

DCAT_006_026_21064779

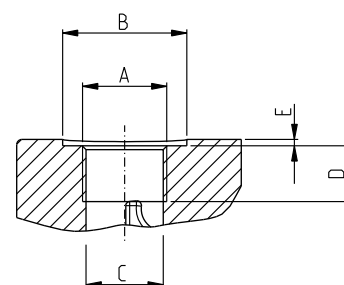

CODE	Nominal size	A	Ø B	Ø C	D	E		
			mm (in)	mm (in)	mm (in)	mm (in)	Nm (lbf in)	Nm (lbf in)
GC	3/8"	G 3/8	30 (#) (1.1811)	15 (0.5906)	10 (#) (0.3937)	2 (#) (0.0787)	15 ⁺¹ (#) (133 ÷ 142)	—
			—		14 (0.5512)	—	15 ⁺¹ (133 ÷ 142)	25 ⁺¹ (221 ÷ 230)
GD	1/2"	G 1/2	—	19 (0.7480)	14 (0.5512)	—	20 ⁺¹ (177 ÷ 186)	50 ^{+2,5} (443 ÷ 465)
			—		17 (◆) (0.6693)	—	—	—
GE	3/4"	G 3/4	—	24,5 (0.9646)	18 (0.7087)	—	30 ^{+2,5} (266 ÷ 288)	90 ⁺⁵ (797 ÷ 841)
GF	1"	G 1	—	30,5 (1.2008)	18 (0.7086)	—	50 ^{+2,5} (443 ÷ 465)	130 ⁺¹⁰ (1151 ÷ 1239)
GG	1" 1/4	G 1 1/4	—	39 (1.5354)	22 (0.8661)	—	60 ⁺⁵ (531 ÷ 575)	170 ⁺¹⁰ (1505 ÷ 1593)
GH	1" 1/2	G 1 1/2	—	45 (1.7716)	24 (0.9448)	—	70 ⁺⁵ (620 ÷ 664)	210 ⁺¹⁵ (1859 ÷ 1992)

(#) = Drain port

(◆) For POLARIS 20

02/07.2006

PORTS SIZES



Tightening torque for low pressure side port



Tightening torque for high pressure side port [values obtained at 5075 psi (350 bar)]

For reversible rotation, please consult only the tightening torque for high pressure side port

SAE STRAIGHT THREAD PORTS J514

ODT

American straight thread UNC-UNF 60° conforms to ANSI B 1.1

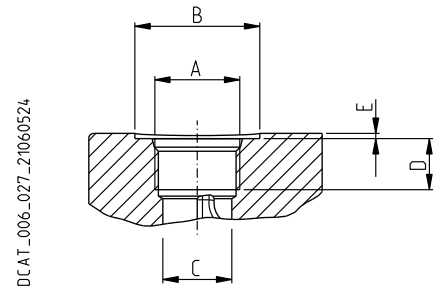

CODE	Nominal size	A	Ø B		Ø C		D	E		
			mm (in)	mm (in)	mm (in)	mm (in)				
OA	3/8"	9/16" - 18 UNF - 2B	26 (1.0236)	13 (0.5118)	15 (0.5906)	1	15 ⁺¹	25 ⁺¹		
						(0.03934)	(133 ÷ 142)	(221 ÷ 230)		
OB	1/2"	3/4" - 16 UNF - 2B	32 (1.2598)	17,5 (0.690)	15 (0.5906)	—	20 ⁺¹	45 ^{+2,5}		
							(177 ÷ 186)	(398 ÷ 420)		
OC	5/8"	7/8" - 14 UNF - 2B	35 (1.3780)	20,5 (0.8071)	15 (◆)	0,5	30 ^{+2,5}	70 ⁺⁵		
					(0.5906)	(0.0197)	(266 ÷ 288)	(620 ÷ 664)		
OD	3/4"	1 1/16" - 12 UNF - 2B	42 (1.6535)	24,8 (0.9764)	20 (0.7874)	0,5	40 ^{+2,5}	120 ⁺¹⁰		
						(0.0197)	(354 ÷ 376)	(1062 ÷ 1151)		
OF	1"	1 5/16" - 12 UNF - 2B	49 (1.9291)	30,5 (1.2008)	20 (0.7874)	0,5	60 ⁺⁵	170 ⁺¹⁰		
						(0.0197)	(531 ÷ 575)	(1505 ÷ 1593)		
OG	1" 1/4	1 5/8" - 12 UNF - 2B	58 (2.2835)	39,1 (1.5394)	20 (0.7874)	0,5	70 ⁺⁵	200 ⁺¹⁵		
						(0.0197)	(620 ÷ 664)	(1770 ÷ 1858)		
OH	1" 1/2	1 7/8" - 12 UNF - 2B	65 (2.5591)	45 (1.7717)	20 (0.7874)	0,5	100 ⁺⁵	270 ⁺¹⁵		
						(0.0197)	(885 ÷ 929)	(2389 ÷ 2522)		

(#) = Drain port

(◆) For POLARIS 10

01/10.03

CHANGING ROTATION

Example of changing rotation: from PLP20 pump clockwise to counterclockwise

To change rotation of Polaris unidirectional pumps and motors it is necessary to operate in the following way:

1. Clean the pump externally with care.
2. Loosen, and remove, the clamp bolts (1).
3. Coat the sharp edges of the drive shaft (4) with adhesive tape and smear a layer of clean grease on the shaft end extension to avoid damaging the lip of the shaft seal when removing the mounting flange.
4. Remove the mounting flange (2), taking care to keep the flange as straight as possible during removal. If the flange is stuck, tap around the edge with a fibre or rubber mallet in order to break away from the body. Ensure that while removing the front mounting flange, the drive shaft and other components remain in position.

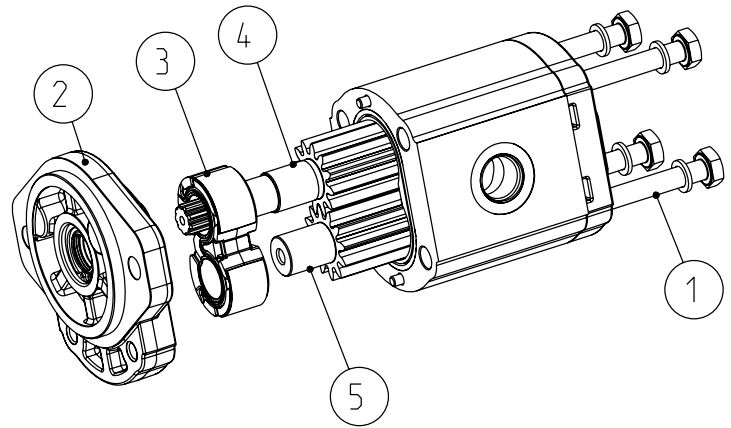

DCA7_033_040

5. Ease the drive gear (4) up to facilitate removal the front plate (3), taking care that the precision ground surfaces do not become damaged, and remove the drive gear.
6. Remove the driven gear (5) without overturning. The rear plate has not to be removed.

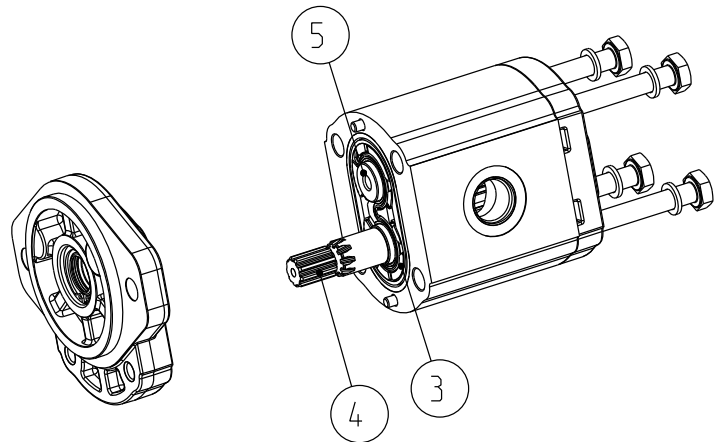

DCA7_033_029

7. Re-locate the driven gear (5) in the position previously occupied by the drive gear (4)
8. Re-locate the drive gear (4) in the position previously occupied by the driven gear (5).
9. Replace the front plate (3) in its original position.

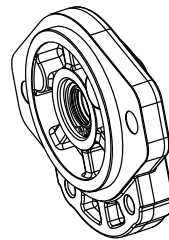

10. Gently wipe the machined surface of the mounting flange (2) and the body with a flat hand stone.

01/10.03

11. Refit the front mounting flange (2) turned 180° from its original position.
12. Refit the clamp bolts (1) with the washers and tighten in a crisscross pattern with the following torque value:
70 ⁺⁵ Nm (620 ÷ 664 lbf in) with cast iron cover.
45 ⁺⁵ Nm (398 ÷ 443 lbf in) with one or both cover in aluminium.

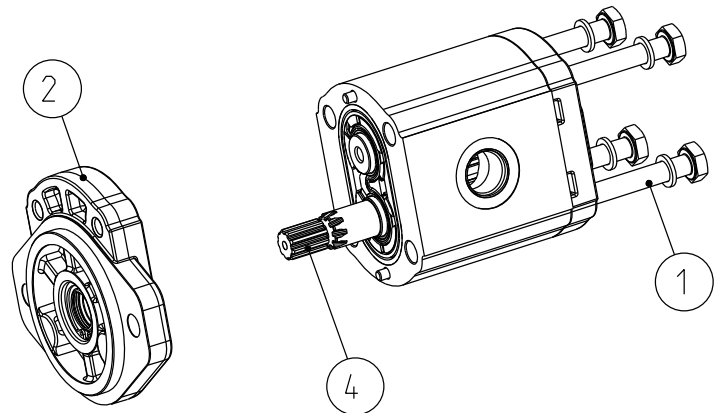

DCA7_033_011

13. Check that the pump rotates freely when the drive shaft (4) is turned by hand. If not a pressure plate seal may be pinched.

14. The pump is ready for installation with the original rotation reversed.

INSTRUCTIONS

INSTALLATION

Pump

The direction of rotation of single-rotation pumps must be the same as that of the drive shaft. Check that the coupling flange correctly aligns the transmission shaft and the pump shaft. Flexible couplings should be used (never rigid fittings) which will not generate an axial or radial load on the pump shaft.

Motor

The direction of rotation of single-rotation motors must match circuit connections. Check that the coupling flange correctly aligns the transmission shaft and the motor shaft. Flexible couplings should be used (never rigid fittings) which will not generate an axial or radial load on the motor shaft.

TANK

Tank capacity must be sufficient for the system's operating conditions (~ 3 times the amount of oil in circulation) to avoid overheating of the fluid. A heat exchanger should be installed if necessary. The intake and return lines in the tank must be spaced apart (by inserting a vertical divider) to prevent the return-line oil from being taken up again immediately.

LINES

The lines must have a major diameter which is at least as large as the diameter of pump or motor ports, and must be perfectly sealed. To reduce loss of power, the lines should be as short as possible, reducing the sources of hydraulic resistance (elbow, throttling, gate valves, etc.) to a minimum. A length of flexible tubing is recommended to reduce the transmission of vibrations. All return lines must end below the minimum oil level, to prevent foaming. Before connecting the lines, remove any plugs and make sure that the lines are perfectly clean.

FILTERS

We recommend filtering the entire system flow. Filters on suction and return line must be fitted in according to the contamination class as indicated in the first pages of the catalogue. Casappa recommends to use its own production filters:



HYDRAULIC FLUID

Use hydraulic fluid conforming to ISO/DIN standards, having viscosity as specified in the first pages of the catalogue. Avoid using mixtures of different oils which could result in decomposition and reduction of the oil's lubricating power.

STARTING UP

Check that all circuit connections are tight and that the entire system is completely clean. Insert the oil in the tank, using a filter. Bleed the circuit to assist in filling. Set the pressure relief valves to the lowest possible setting. Turn on the system for a few moments at minimum speed, then bleed the circuit again and check the level of oil in the tank. In the difference between pump or motor temperature and fluid temperature exceeds 50°F (10 °C), rapidly switch the system on and off to heat it up gradually. Then gradually increase the pressure and speed of rotation until the pre-set operating levels as specified in the catalogue are attained.

PERIODICAL CHECKS - MAINTENANCE

Keep the outside surface clean especially in the area of the drive shaft seal. In fact, abrasive powder can accelerate wear on the seal and cause leakage. Replace filters regularly to keep the fluid clean. The oil level must be checked and oil replaced periodically depending on the system's operating conditions.

Replaces: 01/10.03

02/07.2006

VALVE OPTIONS (◆)

PRIORITY VALVE

P1

Costant delivery and internal recirculation of excess flow.

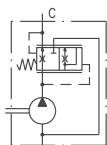

P2

Costant delivery at controlled pressure. Internal recirculation of excess flow and drain valve.

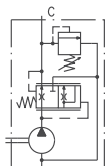

P3

Costant delivery at controlled pressure. Excess flow and drain valve must be connected to tank.

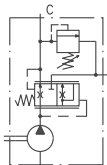

P4

Costant delivery and excess flow can both be used under load.

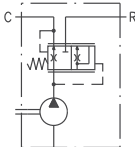

P5T

Costant delivery at controlled pressure with drain valve connected to tank. Excess flow can be used under load.

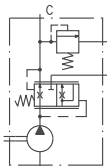

P7

Costant delivery. Excess flow at controlled pressure can be used under load. Internal recirculation of drain valve.

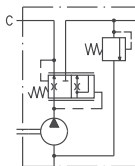

P9

Costant delivery at controlled pressure. Internal recirculation of valve drain. Excess flow can be used under load.

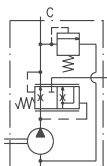

ELECTRIC VALVE FOR MOTORS

EC08..

By-pass valve normally closed with max. pressure relief valve and anti-cavitation valve.

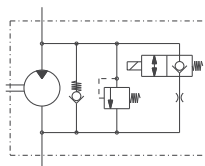

DBVSA..

Proportional relief valve and anti-cavitation valve.

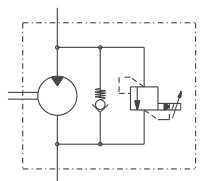

MAX PRESSURE RELIEF VALVE

VPEF..

Fixed setting with external drain.

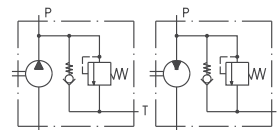

VPIF..

Fixed setting with internal drain.

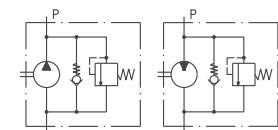

VPER..

Adjustable setting with external drain.

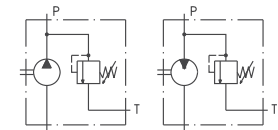

VPIR..

Adjustable setting with internal drain.

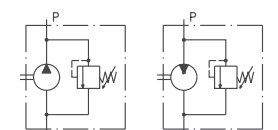

LOAD SENSING VALVE

...

Static.

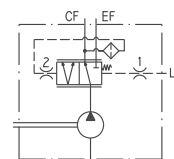

...

Dynamic.

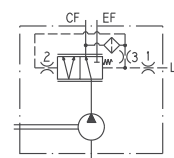

...

Dynamic with relief valve fitted on the main line.

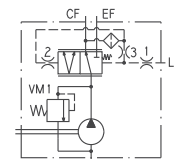

...

Dynamic with relief valve fitted on controlled line.

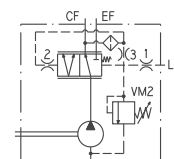

CHECK VALVE

V8

Anti-cavitation valve.

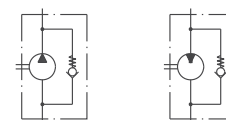

01/10.03

(◆) For more information please consult our technical sales department.

HOW TO ORDER POLARIS 10 SINGLE UNITS

1	2	3	4	5	6	7	8	9	10	11	12	13							
PLP 10-1	L	0	-	81	E1	-	L	BB/BA	-	N	-	EL	-	C	-	L	GA	-	FS

1	Type	Pump type	Motor type
0.07 in ³ /rev (1,07 cm ³ /rev)		PLP 10-1	PLM 10-1
0.10 in ³ /rev (1,60 cm ³ /rev)		PLP 10-1,5	PLM 10-1,5
0.13 in ³ /rev (2,13 cm ³ /rev)		PLP 10-2	PLM 10-2
0.16 in ³ /rev (2,67 cm ³ /rev)		PLP 10-2,5	PLM 10-2,5
0.20 in ³ /rev (3,34 cm ³ /rev)		PLP 10-3,15	PLM 10-3,15
0.26 in ³ /rev (4,27 cm ³ /rev)		PLP 10-4	PLM 10-4
0.33 in ³ /rev (5,34 cm ³ /rev)		PLP 10-5	PLM 10-5
0.38 in ³ /rev (6,20 cm ³ /rev)		PLP 10-5,8	PLM 10-5,8
0.41 in ³ /rev (6,67 cm ³ /rev)		PLP 10-6,3	PLM 10-6,3
0.52 in ³ /rev (8,51 cm ³ /rev)		PLP 10-8	PLM 10-8
0.65 in ³ /rev (10,67 cm ³ /rev)		PLP 10-10	PLP 10-10

2	Rotation	Code
Left		S
Right		D
Reversible rear external drain		R
Reversible side external drain		L
Reversible internal drain		B

3	Version	Code
Without outboard bearing		0

4	Drive shaft	Code
European tapered 1:8		81
European tapered 1:8		86
SAE "AA" spline (9 teeth)		02
SAE "AA" straight		30
SAE straight		36
Straight		29

5	Mounting flange	Code
European		E1
European		E7
European		E8
German 2 bolt		B1
German 4 bolt		K2
SAE "AA" 2 bolt		S0
SAE "AA" 2-4 bolt		R9
SAE 2-4 bolt		R8
SAE 2 bolt		W9

Code	Ports position	6
L	Side	
P	Rear	

Code	Ports IN/OUT	7
GERMAN FLANGED PORTS		
Side	Rear	Type
BB/BA	PLP 10	1-1,5-2-2,5-3,15
BA/BB	PLM 10	4-5-5,8-6,3-8-10

GAS STRAIGHT THREAD PORTS (BSPP)		
Side	Rear	Type
GC/GC	PLP 10	1-1,5-2-2,5-3,15-4
	PLM 10	
GD/GD	PLP 10	5-5,8-6,3-8-10
	PLM 10	

SAE STRAIGHT THREAD PORTS (ODT)		
Side	Rear	Type
OB/OA	PLP 10	1-1,5-2-2,5-3,15-4
OA/OB	PLM 10	5-5,8-6,3
OC/OB	PLP 10	8-10
OB/OC	PLM 10	

Code	Seals (a)	8
N	Buna (standard)	
V	Viton	

Code	Cover options (b)	9
	Cast iron mounting flange and rear cover (standard - no code)	
E	Aluminium mounting flange and cast iron rear cover	
L	Cast iron mounting flange and aluminium rear cover	
EL	Aluminium mounting flange and rear cover	

Code	Shaft seal options	10
C	High back pressure seal with wiper seal	
D	Standard seal with wiper seal	
H	High back pressure seal	

Replaces: 01/10.03

02/07.2006

HOW TO ORDER POLARIS 10 SINGLE UNITS

Replaces: 01/10.03

11	Drain port position - Rev. Rotation L	Code
	Side drain with side port position	L
	Side drain with bottom port position	*

12	Drain port		Code
IN/OUT GERMAN FLANGED PORTS			
	Type	Side	Rear
	1-1,5-2-2,5-3,15	PLP 10	
	4-5-5,8-6,3-8-10	GA	
		PLM 10	
IN/OUT GAS STRAIGHT THREAD PORTS (BSPP)			
	Type	Side	Rear
	1-1,5-2-2,5-3,15	PLP 10	
	4-5-5,8-6,3-8-10	GA	GA
		PLM 10	
IN/OUT SAE STRAIGHT THREAD PORTS (ODT)			
	Type	Side	Rear
	1-1,5-2-2,5-3,15	PLP 10	
	4-5-5,8-6,3-8-10	03	03
		PLM 10	

13	Shaft arrangement	Code
	Female spline	FS

- (a) Choose the seals according to the temperature shown on page 4.
- (b) Mounting flange material on page 58 ÷ 60
Rear cover material on page 32 ÷ 33



02/07.2006

HOW TO ORDER POLARIS 20 SINGLE UNITS

1	2	3	4	5	6	7	8	9	10	11	12	13							
PLP 20-4	L	0	-	82	E2	-	L	EA/EA	-	N	-	EL	-	C	-	*	GB	-	FS

1	Type	Pump type	Motor type
0.30 in ³ /rev (4,95 cm ³ /rev)		PLP 20-4	PLM 20-4
0.40 in ³ /rev (6,61 cm ³ /rev)		PLP 20-6,3	PLM 20-6,3
0.44 in ³ /rev (7,29 cm ³ /rev)		PLP 20-7,2	PLM 20-7,2
0.50 in ³ /rev (8,26 cm ³ /rev)		PLP 20-8	PLM 20-8
0.56 in ³ /rev (9,17 cm ³ /rev)		PLP 20-9	PLM 20-9
0.66 in ³ /rev (10,9 cm ³ /rev)		PLP 20-10,5	PLM 20-10,5
0.69 in ³ /rev (11,23 cm ³ /rev)		PLP 20-11,2	PLM 20-11,2
0.89 in ³ /rev (14,53 cm ³ /rev)		PLP 20-14	PLM 20-14
1.03 in ³ /rev (16,85 cm ³ /rev)		PLP 20-16	PLM 20-16
1.16 in ³ /rev (19,09 cm ³ /rev)		PLP 20-19	PLM 20-19
1.29 in ³ /rev (21,14 cm ³ /rev)		PLP 20-20	PLM 20-20
1.52 in ³ /rev (24,84 cm ³ /rev)		PLP 20-24,5	PLM 20-24,5
1.61 in ³ /rev (26,42 cm ³ /rev)		PLP 20-25	PLM 20-25
1.72 in ³ /rev (28,21 cm ³ /rev)		PLP 20-27,8	PLM 20-27,8
2.01 in ³ /rev (33,03 cm ³ /rev)		PLP 20-31,5	PLM 20-31,5

2	Rotation	Code
Left		S
Right		D
Reversible rear external drain		R
Reversible side external drain		L
Reversible internal drain		B

3	Version	Code
Without outboard bearing		0
With outboard bearing		W8
With outboard bearing		4
With outboard bearing		5
With outboard bearing		6
With outboard bearing		7
With outboard bearing		8
With outboard bearing		9

4	Drive shaft	Code
European tapered 1:8		82
German tapered 1:5		54
German tapered 1:5		55
Straight		46
SAE "A" spline (9 teeth)		03
SAE spline (10 teeth)		01
SAE "A" spline (11 teeth)		07
SAE "A" straight		31

Code	Drive shaft	4
49	Straight	
50	Straight	
04	SAE "B" spline	
32	SAE "B" straight	
12	DIN 54 82	
48	Straight (only for version 6)	
B1	Straight (only for version 8)	
95	Tang	

Code	Mounting flange	5
E2	European	
B2	German	
B4	German 2 bolt	
B5	German 2 bolt	
B6	German 4 bolt	
S1	SAE "A" 2 bolt	
S2	SAE "A" 2 bolt	
S9	SAE "A" 2 bolt	
S5	SAE "B" 2 bolt	
W8	German	

Code	Ports position	6
L	Side	
P	Rear	

Code	Ports IN/OUT	7	
GERMAN FLANGED PORTS			
	Side	Rear	Type
BE/BC	PLP 20	4-6,3-7,2-8-9-10,5-11,2	
BC/BE	PLM 20	14-16-19-20-24,5-25	27,8-31,5
EUROPEAN FLANGED PORTS			
	Side	Rear	Type
EA/EA	PLP 20	4-6,3-7,2-8-9-10,5-11,2	
	PLM 20		
EB/EA	PLP 20	14-16-19-20-24,5-25	
EA/EB	PLM 20	27,8-31,5	

01/10.03

HOW TO ORDER POLARIS 20 SINGLE UNITS

Replaces: 01/10.03

7	Ports IN/OUT	Code
SAE FLANGED PORTS (SSM)		
Type	Side	Rear
4-6,3-7,2-8-9-10,5-11,2	PLP 20	MA/MA
	PLM 20	MA/MA
14-16-19-20	PLP 20	MB/MA
	PLM 20	MA/MB
24,5-25-27,8-31,5	PLP 20	MC/MB
	PLM 20	MB/MC
SAE FLANGED PORTS (SSS)		
Type	Side	Rear
4-6,3-7,2-8-9-10,5-11,2	PLP 20	SA/SA
	PLM 20	SA/SA
14-16-19-20	PLP 20	SB/SA
	PLM 20	SA/SB
24,5-25-27,8-31,5	PLP 20	SC/SB
	PLM 20	SB/SC
GAS STRAIGHT THREAD PORTS (BSPP)		
Type	Side	Rear
4-6,3-7,2-8-9 10,5-11,2	PLP 20	GD/GD
	PLM 20	GD/GD
14-16-19-20-24,5-25 27,8-31,5	PLP 20	GE/GD
	PLM 20	GD/GE
SAE STRAIGHT THREAD PORTS (ODT)		
Type	Side	Rear
4-6,3-7,2-8-9-10,5-11,2	PLP 20	OC/OC
	PLM 20	OC/OC
14-16-19-20-24,5-25 27,8-31,5	PLP 20	OD/OC
	PLM 20	OC/OD

8	Seals (a)	Code
	Buna (standard)	N
	Viton	V

9	Cover options (b)	Code
	Cast iron mounting flange and rear cover (standard - no code)	
	Aluminium mounting flange and cast iron rear cover	E
	Cast iron mounting flange and aluminium rear cover	L
	Aluminium mounting flange and rear cover	EL

10	Shaft seal options	Code
	High back pressure seal with wiper seal	C
	Standard seal with wiper seal	D
	High back pressure seal	H

Code	Drain port position - Rev. rotation L	11
L	Side drain with side port position	
*	Side drain with bottom port position	

Code	Drain port	12
IN/OUT GERMAN FLANGED PORTS		
Side	Rear	Type
TA	PLP 20	4-6,3-7,2-8-9-10,5-11,2
	PLM 20	24,5-25-27,8-31,5

IN/OUT EUROPEAN FLANGED PORTS		
Side	Rear	Type
GB	PLP 20	4-6,3-7,2-8-9-10,5-11,2
	PLM 20	24,5-25-27,8-31,5

IN/OUT SAE FLANGED PORTS (SSM)		
Side	Rear	Type
GB	PLP 20	4-6,3-7,2-8-9-10,5-11,2
	PLM20	24,5-25-27,8-31,5

IN/OUT SAE FLANGED PORTS (SSS)		
Side	Rear	Type
03	PLP 20	4-6,3-7,2-8-9-10,5-11,2
	PLM 20	24,5-25-27,8-31,5

IN/OUT GAS STRAIGHT THREAD PORTS (BSPP)		
Side	Rear	Type
GB	PLP 20	4-6,3-7,2-8-9-10,5-11,2
	PLM 20	24,5-25-27,8-31,5

IN/OUT SAE STRAIGHT THREAD PORTS (ODT)		
Side	Rear	Type
03	PLP 20	4-6,3-7,2-8-9-10,5-11,2
	PLM 20	24,5-25-27,8-31,5

Code	Shaft arrangement	13
FS	Female spline	

- (a) Choose the seals according to the temperature shown on page 4.
- (b) Mounting flange material on page 61 ÷ 65
Rear cover material on page 34 ÷ 35

02/07.2006

HOW TO ORDER POLARIS 30 SINGLE UNITS

1	2	3	4	5	6	7	8	9	10					
PLP 30-22	R	0	-	83	E3	-	L	ED/EB	-	N	-	C	-	FS

1	Type	Pump type	Motor type
1.34 in ³ /rev (21,99 cm ³ /rev)		PLP 30-22	PLM 30-22
1.63 in ³ /rev (26,70 cm ³ /rev)		PLP 30-27	PLM 30-27
2.11 in ³ /rev (34,55 cm ³ /rev)		PLP 30-34	PLM 30-34
2.40 in ³ /rev (39,27 cm ³ /rev)		PLP 30-38	PLM 30-38
2.68 in ³ /rev (43,98 cm ³ /rev)		PLP 30-43	PLM 30-43
3.16 in ³ /rev (51,83 cm ³ /rev)		PLP 30-51	PLM 30-51
3.74 in ³ /rev (61,26 cm ³ /rev)		PLP 30-61	PLM 30-61
4.50 in ³ /rev (73,82 cm ³ /rev)		PLP 30-73	PLM 30-73
4.98 in ³ /rev (81,68 cm ³ /rev)		PLP 30-82	PLM 30-82
5.56 in ³ /rev (91,10 cm ³ /rev)		PLP 30-90	PLM 30-90

2	Rotation	Code
Left		S
Right		D
Reversible rear external drain		R

3	Version	Code
Without outboard bearing		0

4	Drive shaft	Code
European tapered 1:8		83
European tapered 1:8		84
German tapered 1:5		56
Straight		41
SAE "B" spline		A8
SAE "BB" spline		A5
SAE "B" spline		04
SAE "BB" spline		05
SAE "B" straight		32
SAE "BB" straight		33

5	Mounting flange	Code
European		E3
European		E4
German		B3
SAE "B" 2 bolt		S5
SAE "B" 2 bolt		U3

6	Ports position	Code
Side		L

Code	Ports IN/OUT	7
GERMAN FLANGED PORTS		
Side		Type
BM/BL	PLP 30	22-27-34-38-43
BL/BM	PLM 30	46-51-61-73-82-90
EUROPEAN FLANGED PORTS		
Side		Type
ED/EB	PLP 30	22-27-34-38-43
EB/ED	PLM 30	46-51-61
EF/ED	PLP 30	73-82-90
ED/EF	PLM 30	
SAE FLANGED PORTS (SSM)		
Side		Type
MB/MA	PLP 30	22
MA/MB	PLM 30	
MC/MB	PLP 30	27-34
MB/MC	PLM 30	
MD/MC	PLP 30	38-43-46-51
MC/MD	PLM 30	
ME/MD	PLP 30	61-73-82
MD/ME	PLM 30	
MF/ME	PLP 30	90
ME/MF	PLM 30	
SAE FLANGED PORTS (SSS)		
Side		Type
SB/SA	PLP 30	22
SA/SB	PLM 30	
SC/SB	PLP 30	27-34
SB/SC	PLM 30	
SD/SC	PLP 30	38-43-46-51
SC/SB	PLM 30	
SE/SD	PLP 30	61-73-82
SD/SE	PLM 30	
SF/SE	PLP 30	90
SE/SF	PLM 30	
GAS STRAIGHT THREAD PORTS (BSPP)		
Side		Type
GF/GF	PLP 30	22-27-34-38-43-46-51
GG/GF	PLM 30	
GG/GF	PLP 30	61-73
GF/GG	PLM 30	
GH/GG	PLP 30	82-90
GG/GH	PLM 30	

01/10.03

HOW TO ORDER POLARIS 30 SINGLE UNITS

7	Ports IN/OUT	Code
SAE STRAIGHT THREAD PORTS (ODT)		
Type		Rear
22-27-34	PLP 30	OF/OD
	PLM 30	OD/OF
38-43-46-51	PLP 30	OG/OF
	PLM 30	OF/OG
61-73-82-90	PLP 30	OH/OG
	PLM 30	OG/OH

8	Seals (a)	Code
	Buna (standard)	N
	Viton	V

9	Shaft seal options	Code
	High back pressure seal with wiper seal	C
	Standard seal with wiper seal	D
	High back pressure seal	H

10	Shaft arrangement	Code
	Female spline	FS

(a) Choose the seals according to the temperature shown on page 4.

01/10.03

HOW TO ORDER POLARIS 10 MULTIPLE PUMPS

1	2	3	4	5	6	7	8	9	10	11	12
PLP 10-1 - 81 E1 - L BA/BA /											
Front section											
10-1 - L BA/BA /											
Intermediate section											
10-1 - L **/BA - V7 - S 0 - N - EL - C / FS											
Rear section											

1	Type	Pump type
0.07 in ³ /rev (1,07 cm ³ /rev)		PLP 10-1
0.10 in ³ /rev (1,60 cm ³ /rev)		PLP 10-1,5
0.13 in ³ /rev (2,13 cm ³ /rev)		PLP 10-2
0.16 in ³ /rev (2,67 cm ³ /rev)		PLP 10-2,5
0.20 in ³ /rev (3,34 cm ³ /rev)		PLP 10-3,15
0.26 in ³ /rev (4,27 cm ³ /rev)		PLP 10-4
0.33 in ³ /rev (5,34 cm ³ /rev)		PLP 10-5
0.38 in ³ /rev (6,20 cm ³ /rev)		PLP 10-5,8
0.41 in ³ /rev (6,67 cm ³ /rev)		PLP 10-6,3
0.52 in ³ /rev (8,51 cm ³ /rev)		PLP 10-8
0.65 in ³ /rev (10,67 cm ³ /rev)		PLP 10-10

2	Drive shaft	Code
European tapered 1:8		81
European tapered 1:8		86
SAE "AA" spline (9 teeth)		02
SAE "AA" straight		30
SAE straight		36
Straight		29

3	Mounting flange	Code
European		E1
European		E7
European		E8
German 2 bolts		B1
German 4 bolts		K2
SAE "AA" 2 bolt		S0
SAE "AA" 2-4 bolt		R9
SAE 2-4 bolt		R8
SAE 2 bolt		W9

4	Ports position	Code
Side		L

Code	Ports IN/OUT	5
GERMAN FLANGED PORTS		
Side	Type	
BB/BA	PLP 10	1-1,5-2-2,5-3,15-4-5-5,8-6,3-8-10
GAS STRAIGHT THREAD PORTS (BSPP)		
Side	Type	
GC/GC	PLP 10	1-1,5-2-2,5-3,15-4
GD/GD	PLP 10	5-5,8-6,3-8-10
SAE STRAIGHT THREAD PORTS (ODT)		
Side	Type	
OB/OA	PLP 10	1-1,5-2-2,5-3,15-4-5-5,8-6,3
OC/OB	PLP 10	8-10

Code	Combination type	6
V6	Standard	
V7	Common inlet	

Code	Rotation	7
S	Left	
D	Right	

Code	Version	8
0	Without outboard bearing (standard) no code	

Code	Seals (a)	9
N	Buna N (standard)	
V	Viton	

Code	Cover options (b)	10
	Cast iron mounting flange and rear cover (standard - no code)	
E	Aluminium mounting flange and cast iron rear cover	
L	Cast iron mounting flange and aluminium rear cover	
EL	Aluminium mounting flange and rear cover	

Replaces: 01/10.03

02/07.2006

HOW TO ORDER POLARIS 10 MULTIPLE PUMPS

Replaces: 01/10.03

11	Shaft seal options	Code
	High back pressure seal with wiper seal	C
	Standard seal with wiper seal	D
	High back pressure seal	H

12	Shaft arrangement	Code
	Female spline	FS

- (a) Choose the seals according to the temperature shown on page 4.
- (b) Mounting flange material on page 58 ÷ 60
Rear cover material on page 43

 02/07.2006

HOW TO ORDER POLARIS 20 MULTIPLE PUMPS

1	2	3	4	5	6	7	8	9	10	11	12
PLP 20-4 - 82 E2 - L EA/EA /											
Front section											
20-4 - L EA/EA /											
Intermediate section											
20-4 - L **/EA - S7 - S 0 - N - EL - C / FS											
Rear section											

1	Type	Pump Type
	0.30 in ³ /rev (4,95 cm ³ /rev)	PLP 20-4
	0.40 in ³ /rev (6,61 cm ³ /rev)	PLP 20-6,3
	0.44 in ³ /rev (7,29 cm ³ /rev)	PLP 20-7,2
	0.50 in ³ /rev (8,26 cm ³ /rev)	PLP 20-8
	0.56 in ³ /rev (9,17 cm ³ /rev)	PLP 20-9
	0.66 in ³ /rev (10,9 cm ³ /rev)	PLP 20-10,5
	0.69 in ³ /rev (11,23 cm ³ /rev)	PLP 20-11,2
	0.89 in ³ /rev (14,53 cm ³ /rev)	PLP 20-14
	1.03 in ³ /rev (16,85 cm ³ /rev)	PLP 20-16
	1.16 in ³ /rev (19,09 cm ³ /rev)	PLP 20-19
	1.29 in ³ /rev (21,14 cm ³ /rev)	PLP 20-20
	1.52 in ³ /rev (24,84 cm ³ /rev)	PLP 20-24,5
	1.61 in ³ /rev (26,42 cm ³ /rev)	PLP 20-25
	1.72 in ³ /rev (28,21 cm ³ /rev)	PLP 20-27,8
	2.01 in ³ /rev (33,03 cm ³ /rev)	PLP 20-31,5

2	Drive shaft	Code
	European tapered 1:8	82
	German tapered 1:5	54
	German tapered 1:5	55
	Straight	46
	SAE "A" spline (9 teeth)	03
	SAE spline (10 teeth)	01
	SAE "A" spline (11 teeth)	07
	SAE "A" straight	31
	Straight	49
	Straight	50
	SAE "B" spline	04
	SAE "B" straight	32
	DIN 54 82 spline	12
	Straight (only for version 6)	48
	Straight (only for version 8)	B1
	Tang	95

Code	Mounting flange	3
E2	European	
B2	German	
B4	German 2 bolt	
B5	German 2 bolt	
B6	German 4 bolt	
S1	SAE "A" 2 bolt	
S2	SAE "A" 2 bolt	
S9	SAE "A" 2 bolt	
S5	SAE "B" 2 bolt	
W8	German	

Code	Ports position	4
L	Side	

Code	Ports IN/OUT	5
GERMAN FLANGED PORTS		
Side	Type	
BE/BC	PLP 20	4-6,3-7,2-8-9-10,5-11,2 14-16-19-20-24,5-25 27,8-31,5
EUROPEAN FLANGED PORTS		
Side	Type	
EA/EA	PLP 20	4-6,3-7,2-8-9-10,5-11,2
EB/EA	PLP 20	14-16-19-20-24,5-25 27,8-31,5
SAE FLANGED PORTS (SSM)		
Side	Type	
MA/MA	PLP 20	4-6,3-7,2-8-9-10,5-11,2
MB/MA	PLP 20	14-16-19-20
MC/MB	PLP 20	24,5-25-27,8-31,5
SAE FLANGED PORTS (SSS)		
Side	Type	
SA/SA	PLP 20	4-6,3-7,2-8-9-10,5-11,2
SB/SA	PLP 20	14-16-19-20
SC/SB	PLP 20	24,5-25-27,8-31,5

01/10.03

HOW TO ORDER POLARIS 20 MULTIPLE PUMPS

Replaces: 01/10.03

5	Ports IN/OUT	Code
GAS STRAIGHT THREAD PORTS (BSPP)		
Type	Rear	
4-6,3-7,2-8-9-10,5-11,2	PLP 20	GD/GD
14-16-19-20-24,5-25-27,8-31,5	PLP 20	GE/GD
SAE STRAIGHT THREAD PORTS (ODT)		
Type	Rear	
4-6,3-7,2-8-9-10,5-11,2	PLP 20	OC/OC
14-16-19-20-24,5 25-27,8-31,5	PLP 20	OD/OC

6	Combination type	Code
	Standard	S6
	Common inlet	S7
	Separate stages	Z6

7	Rotation	Code
	Left	S
	Right	D

8	Version	Code
	Without outboard bearing (standard) no code	0
	With outboard bearing	W8
	With outboard bearing	4
	With outboard bearing	5
	With outboard bearing	6
	With outboard bearing	7
	With outboard bearing	8
	With outboard bearing	9

Code	Seals (a)	9
N	Buna (standard)	
V	Viton	

Code	Cover options (b)	10
	Cast iron mounting flange and rear cover (standard - no code)	
E	Aluminium mounting flange and cast iron rear cover	
L	Cast iron mounting flange and aluminium rear cover	
EL	Aluminium mounting flange and rear cover	

Code	Shaft seal options	11
C	High back pressure seal with wiper seal	
D	Standard shaft seals with wiper seal	
H	High back pressure seal	

Code	Shaft arrangement	12
FS	Female spline	

(a) Choose the seals according to the temperature shown on page 4.

(b) Mounting flange material on page 61 ÷ 65
Rear cover material on page 44

0

02/07.2006

HOW TO ORDER POLARIS 30 MULTIPLE PUMPS

1	2	3	4	5	6	7	8	9	10	11						
PLP 30-22	-	83	E3	-	L	ED/EB	/									
Front section																
30-22	-			L	ED/EB	/										
Intermediate section																
30-22	-			L	ED/EB	-	M6	-	S	0	-	N	-	C	/	FS
Rear section																

1	Type	Pump Type
1.34 in ³ /rev (21,99 cm ³ /rev)		PLP 30-22
1.63 in ³ /rev (26,70 cm ³ /rev)		PLP 30-27
2.11 in ³ /rev (34,55 cm ³ /rev)		PLP 30-34
2.40 in ³ /rev (39,27 cm ³ /rev)		PLP 30-38
2.68 in ³ /rev (43,98 cm ³ /rev)		PLP 30-43
3.16 in ³ /rev (51,83 cm ³ /rev)		PLP 30-51
3.74 in ³ /rev (61,26 cm ³ /rev)		PLP 30-61
4.50 in ³ /rev (73,82 cm ³ /rev)		PLP 30-73
4.98 in ³ /rev (81,68 cm ³ /rev)		PLP 30-82
5.56 in ³ /rev (91,10 cm ³ /rev)		PLP 30-90

2	Drive shaft	Code
European tapered 1:8		83
European tapered 1:8		84
German tapered 1:5		56
Straight		41
SAE "B" spline		A8
SAE "BB" spline		A5
SAE "B" spline		04
SAE "BB" spline		05
SAE "B" straight		32
SAE "BB" straight		33

3	Mounting flange	Code
European		E3
European		E4
German		B3
SAE "B" 2 bolt		S5
SAE "B" 2 bolt		U3

4	Ports position	Code
Side		L

Code	Ports IN/OUT	5
GERMAN FLANGED PORTS		
Side		Type
BM/BL	PLP 30	22-27-34-38-43 46-51-61-73-82-90
EUROPEAN FLANGED PORTS		
Side		Type
ED/EB	PLP 30	22-27-34-38-43 46-51-61
EF/ED	PLP 30	73-82-90
SAE FLANGED PORTS (SSM)		
Side	Rear	Type
MB/MA	PLP 30	22
MC/MB	PLP 30	27-34
MD/MC	PLP 30	38-43-46-51
ME/MD	PLP 30	61-73-82
MF/ME	PLP 30	90
SAE FLANGED PORTS (SSS)		
Side	Rear	Type
SB/SA	PLP 30	22
SC/SB	PLP 30	27-34
SD/SC	PLP 30	38-43-46-51
SE/SD	PLP 30	61-73-82
SF/SE	PLP 30	90
GAS STRAIGHT THREAD PORTS (BSPP)		
Side	Rear	Type
GF/GF	PLP 30	22-27-34-38-43-46-51
GG/GF	PLP 30	61-73
GH/GG	PLP 30	82-90
SAE STRAIGHT THREAD PORTS (ODT)		
Side	Rear	Type
OF/OD	PLP 30	22-27-34
OG/OF	PLP 30	38-43-46-51
OH/OG	PLP 30	61-73-82-90

01/10.03

HOW TO ORDER POLARIS 30 MULTIPLE PUMPS

6	Combination type	Code
	Standard	M6

7	Rotation	Code
	Left	S
	Right	D

8	Version	Code
	Without outboard bearing (standard) no code	0

9	Seals (a)	Code
	Buna (standard)	N
	Viton	V

10	Shaft seal options	Code
	High back pressure seal with wiper seal	C
	Standard seal with wiper seal	D
	High back pressure seal	H

11	Shaft arrangement	Code
	Female spline	FS

- (a) Choose the seals according to the temperature shown on page 4.

01/10.03

HOW TO ORDER POLARIS DOUBLE PUMPS DIFFERENT GROUPS

PLP30/PLP20

1	2	3	4	5	6	7	8	9	10	11			
PLP 30-22	-	83	E3	-	L	ED/EB							
Front section													
20-4	-		L	EA/EA		S	0	/	FS	-	L	-	N
Rear section													

PLP30/PLP10

1	2	3	4	5	6	7	8	9	10	11			
PLP 30-22	-	83	E3	-	L	ED/EB	-	52					
Front section													
10-1	-		L	BB/BA	-	S	0	/	FS	-	L	-	N
Rear section													

PLP20/PLP10

1	2	3	4	5	6	7	8	9	10	11			
PLP 20-4	-	82	E2	-	L	EA/EA	-	51					
Front section													
10-1	-		L	BB/BA	-	S	0	/	FS	-	EL	-	N
Rear section													

Replaces: 01/10.03

1	Type	Pump type
	The same of multiple pumps	PLP ..

2	Drive shaft	Code
	The same of multiple pumps	...

3	Mounting flange	Code
	The same of multiple pumps	...

4	Ports position	Code
	Side	L

5	Ports IN/OUT	Code
	The same of multiple pumps	../..

6	Combination type	Code
	PLP30/20 Standard - No code	N6
	PLP30/20 Common inlet	N7
	PLP30/20 Separate stages	Z6
	PLP30/10 Standard - No code	Q6
	PLP30/10 Common inlet	Q7
	PLP20/10 Standard - No code	T6
	PLP20/10 Common inlet	T7
	PLP20/10 Separate stages	Z6

Code	Rotation	7
S	Left	
D	Right	

Code	Version	8
...	The same of multiple pumps	

Code	Shaft arrangement	9
FS	Female spline	

Code	Cover options (a)	10
	Cast iron mounting flange and rear cover (standard - no code)	
E	Aluminium mounting flange and cast iron rear cover (only for PLP20/10)	
L	Cast iron mounting flange and aluminium rear cover	
EL	Aluminium mounting flange and rear cover (only for PLP20/10)	

Code	Seals	11
	The same of multiple pumps	

- (a) Mounting flange material:
 ○ PLP 20 on page 61 ÷ 65 - PLP 30 on page 66 ÷ 68
 Rear cover material:
 PLP 10 on page 43 - PLP 20 on page 44

02/07.2006

Our policy is one of continuous improvement in product. Specification of items may, therefore, be changed without notice.

PL 03 T A

Edition: 03/02.2012

Replaces: PL 02 T A



Headquarters:

CASAPPA S.p.A.

Via Balestrieri, 1

43044 Lemignano di Collecchio

Parma (Italy)

Tel. (+39) 0521 30 41 11

Fax (+39) 0521 80 46 00

IP Videoconferencing

E-mail: info@casappa.com

www.casappa.com

