

PRESA DI FORZA A COMANDO MECCANICO

MECHANICAL CLUTCH POWER TAKE-OFF

CODICE PTO
PTO CODE

1-58

CAMBIO
GEARBOX

ZF IVECO



DIAGRAMMA DI UTILIZZO WORKING CONDITION

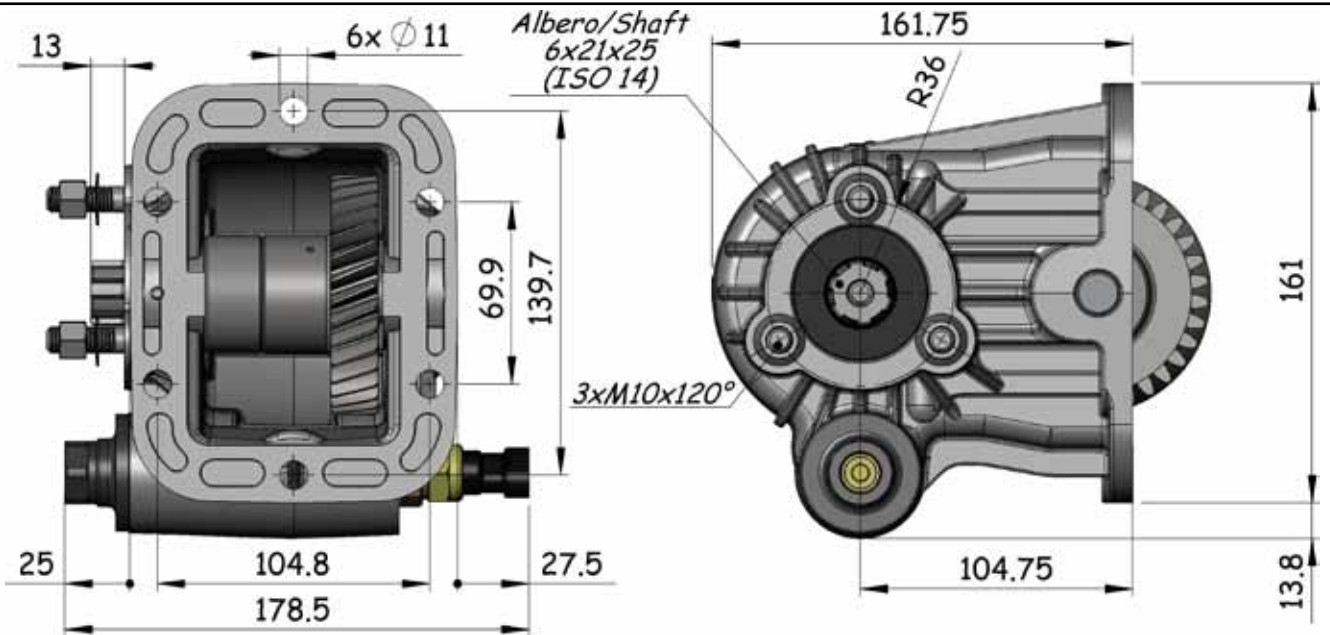
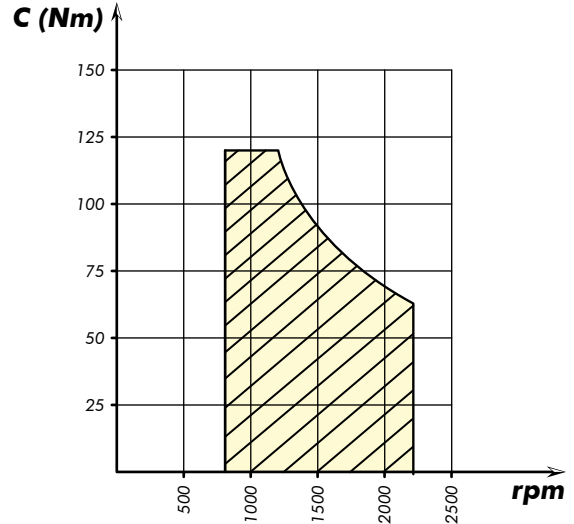

Tipo cambio Gearbox	Codice PTO PTO code	Versione Version	Giri pto a 1000 giri motore Pto ratio@1000 eng.rpm	Coppia massima Max torque	Lato montaggio Mounting side	Uscita Output	Rotazione Rotation	Kit di montaggio Mounting kit	Peso Weight
			rpm	Nm					Kg
IVECO 5S-200 IVECO 5S-270 ZF 5S-200 ZF 5S-270 ZF 5S-300	1-58-134	13	838	120	Sx Left	Poster. Rear	Orar. Cw	154-3-3133	5
ZF 5S-270 VO					Sx/Dx L/R				

pag.1



O.M.F.B. S.p.A. Hydraulic Components
We reserve the right to make any changes without notice.
Edition 2005.01 No reproduction, however partial, is permitted.
Via Cave, 7/9 25050 Provaglia d'Iseo (Brescia) Italy Tel.: +39.030.9830611
Fax: +39.030.9839207-208 Internet:www.omfb.it e-mail:info@omfb.it

COMPANY WITH
QUALITY SYSTEM
CERTIFIED BY DNV
= ISO 9001 =

UŽSISAKYKITE internetu www.dominga.lt/eshop telefonu +370 5 2322231 el. paštu info@dominga.lt

Codice foglio:997-201-05813 Rev: AB

Rev://

Codice fascicolo:

Data: Giovedì 02 aprile 2009